

Delivery Options for Trackmaster Treadmills

All treadmills are delivered crated with the handrails folded down. The treadmill will be strapped down to a wooden skid, and the skid will have a heavy duty cardboard box placed over the top with straps around to keep it secure. The cardboard crating can easily be removed by cutting the straps and lifting the box off the top. The straps will then need to be cut which hold the treadmill onto the crate. The treadmill has wheels on one side to move to the permanent location. It can be lifted from one end and wheeled into location room. The handrails simply fold up and are bolted into place. It is fairly simple to set up but may require two people, one for each side, as the handrails are rather heavy.

Please note that the doorway must be 34" wide for the treadmill to fit through. One other consideration is that the treadmill is also 78" long, uncrated. The hallway must be wide enough to allow for turns if necessary to place in location room.

We offer 4 delivery options. Please see below for further explanation:

Dock Delivery: Your facility must have a loading dock and either a forklift or a pallet jack to move the treadmill off of the truck.

Liftgate Delivery: If your facility does not have a loading dock, we can schedule a liftgate delivery where the truck is equipped with a lift on the back to lower the treadmill to the ground level so that you can then bring the treadmill inside.

Inside Delivery: The treadmill will be delivered into the **front lobby only** by the driver. Once again, the doorway must be wide enough for the crate to fit, 37". It must also be either ground level or have a ramp.

White Glove Delivery: This delivery includes bringing the location in to the location room, setting the treadmill in the desired location, unpacking the treadmill and removing the debris, disposing of all the crating and wrapping. The customer will also receive a call from the trucking company to set up a delivery date and time. A site survey must be filled out by the customer at the location. We must have accurate measurements of all doorways and hallways. We will provide the survey for the customer to fill out and return.

*Drawings of both the treadmill and crating provided in the following pages.

TMX428 Crate Specification

TMX428 SERIES TREADMILL
SHIPPING WEIGHT 550LBS/ 259.5 KG
SHIPPING CLASS 92.5 / 53.3 cu ft
CRATE MATERIAL: CARDBOARD SHELL
WOOD SKID

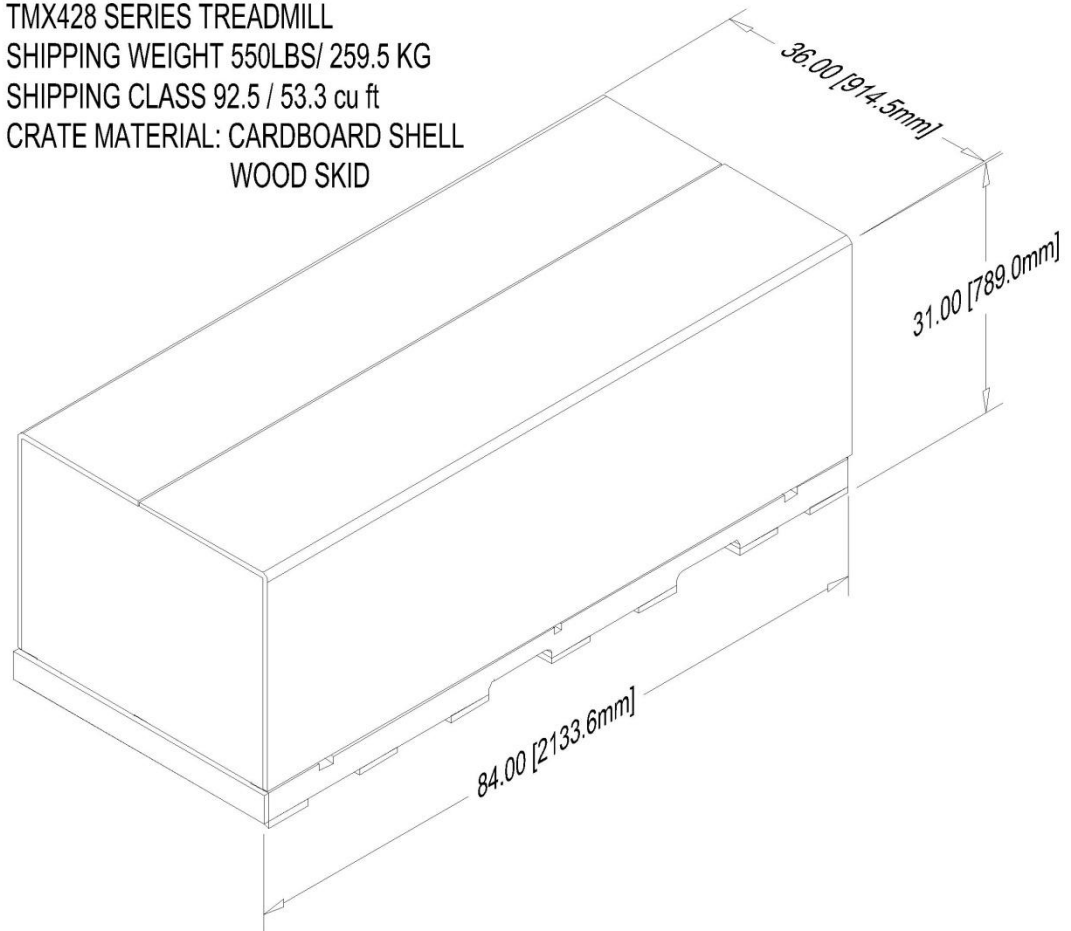

Tools required for assembly

5/16 Allen wrench (supplied)

2. The treadmill is shipped with the handrails loose, straddling the treadmill frame. It is advised that you secure the handrails in their proper location before removing the treadmill from the base of the crate. This prevents the internal wires running down the handrail mount to the motor pan from being cut.
3. With the help of a 2nd person, swing the handrail assembly into the operating position and insert (2) 3/8-16 bolts and 3/8 lock washer each side and tighten securely.
4. Install (2) plastic caps each side for a finished look. Figure 5-1

