



MEDICAL TREADMILL



OWNER'S MANUAL

TMX428
TMX428CP



Contact Information

The model TMX428 TRACKMASTER® treadmill is designed to be interfaced with a variety of ECG and VO₂ systems. If you have a question or need assistance, please contact your system integrator first.

Manufactured by:

3017 Full Vision Drive
Newton, KS 67114 USA
<http://www.full-vision.com>
<http://www.trackmastertreadmills.com>
Phone: (316)-283-3344
Fax: (316)-283-9522
Email: sales2@full-vision.com



(Regulatory affairs only)
Emergo Europe
Westervoortsedijk 60
6827 AT Arnhem
The Netherlands

WARNING

MODIFICATION IS PROHIBITED

The TRACKMASTER® treadmill is manufactured to exacting standards both in physical form and in component selection. The components used in our products have been selected with performance and medical safety in mind. The treadmill has been engineered and certified to conform to the list of medical and safety regulatory standards which appear on the next page. Modification or part substitution of any kind is strictly forbidden. Any deviation in component replacement, physical or electrical modification will result in loss of medical safety certification and warranty of this product. Modifications to this equipment may put the patient at risk of electrical shock or hardware malfunction.

Contact TRACKMASTER® Service department for all your repair part needs.

Publication Information

The information in this manual applies only to the TMX428 Treadmill, and TMX428CP Treadmill. It does not apply to earlier versions. Due to continuing product innovation and state of the art design, specifications in this manual are subject to change without notice.

TRACKMASTER® is a registered trademark. All other marks are the properties of their respective owners.

This product complies with the regulatory requirements concerning medical devices from the following bodies:



Date of first CE mark - August 2013

Revision History

The document part number and revision history appear at the bottom of each page. The revision identifies the document's update level. The revision history of this document is summarized in the following table.

| Revision | Publication Date | Description |
|----------|------------------|--|
| 1 | August 2013 | First Release |
| 2 | October 2015 | Added Chapter 8 Parts List with Part Numbers |
| 3 | August 2016 | Update Authorized Representative Address |
| 4 | January 2018 | Added Chapter 9 Troubleshooting |
| 5 | November 2018 | Added 4 th Edition EMC Tables Chapter 1 |
| 6 | 27 February 2021 | Updated to EU MDR 2017/745 label requirements, added Reprocessing Instructions in Appendix B, updated the intended use statement. |
| 7 | 24 March 2022 | Implementation of New Motor and Drive Combination, 3 Wire Hall Effect Speed Sensor and Harness, Magnetic Pull Tether Clip, Information Label Symbols Updated, EMC Information. Removed Chapter 8 See Service Manual |
| 8 | June 2023 | Updated formatting, updated the EC REP address, added mounting and dismounting method steps, added additional warning to Safety Hazards to review Responsibility of the Customer, added additional warnings in other sections in regards to the Emergency Stop Button and Patient Safety Tether functionality and behavior, removed duplicate warnings and duplicate paragraphs, added images and text for the Patient Safety Tether, removed contradicting information, updated headings and descriptions, added reference to service manual and part number, clarified speed metrics |

| Revision | Publication Date | Description |
|-----------------|-------------------------|--|
| 9 | May 2025 | Updated NOT Life-supporting equipment Table 3 for IEC 60601-1-2:2014+A12020 4.1 Ed. Updated treadmill space requirements. Updated symbols in Chapter 1. Added additional statements for warnings, product overview, and Emergency Stop Switch. Added alternate certification for control panel models. |

Table of Contents

| | |
|--|-----------|
| Contact Information | i |
| Publication Information | ii |
| 1 Introduction..... | 8 |
| Intended User | 8 |
| Intended Use | 8 |
| Regulatory and Safety Information..... | 9 |
| Reporting of serious incident | 9 |
| Safety Conventions | 10 |
| Safety Hazards | 10 |
| Classification of Medical Device..... | 12 |
| Regulatory and Safety Conformance | 12 |
| Table 1: Guidance and Manufacturer’s Declaration – Emissions | 13 |
| Table 2: Guidance and Manufacturer’s Declaration – Immunity All ME Equipment and ME Systems | 13 |
| Table 4: Guidance and Manufacturer’s Declaration – Immunity ME Equipment and ME Systems that is NOT Life-supporting | 15 |
| Table 6: Recommended Separation Distances between portable and mobile RF Communications equipment and the TMX428 Series ME Equipment and ME Systems that is NOT Life-supporting..... | 15 |
| Responsibility of the Manufacturer | 17 |
| Responsibility of the Customer..... | 17 |
| Product and Package Information..... | 18 |
| Symbols..... | 18 |
| Label Locations..... | 21 |
| Serial Decal Information..... | 26 |
| Service Information | 26 |
| Manual Information | 27 |
| Related Documents | 27 |
| Training..... | 27 |
| 2 Specifications..... | 29 |
| Directional Orientation | 29 |
| Safety Systems | 30 |
| Treadmill..... | 30 |

| | | |
|----------|--|-----------|
| | Drive System..... | 30 |
| | Speed Range..... | 30 |
| | Incline Range | 30 |
| | Running Surface..... | 30 |
| | Communication Ports..... | 30 |
| | Floor Surface Footprint..... | 30 |
| | Operating and Storage Condition Recommendations..... | 30 |
| 3 | Power Requirements..... | 32 |
| 4 | Hi-Pot Test Instructions | 34 |
| 5 | Uncrating, Setup and Assembly..... | 36 |
| | Safe Handling Guidelines | 36 |
| | Uncrating Instructions..... | 37 |
| | Initial Setup Instruciton..... | 38 |
| | TMX428CP & TMX58 Control Assembly | 40 |
| | Location | 41 |
| | Final Setup - Running Belt Tracking Adjustment | 41 |
| | Final Setup - Running Belt Tension Adjustment..... | 42 |
| | Final Setup - Drive Belt Tension Adjustment..... | 42 |
| 6 | Operating Instructions | 46 |
| | Electrical Safety Tests..... | 46 |
| | Operating Controls..... | 46 |
| | Controlling the Treadmill | 46 |
| | Power Switch | 46 |
| | Emergency Stop Switch..... | 46 |
| | Emergency Stop Switch Check..... | 46 |
| | Patient Safety Tether Switch..... | 47 |
| | Patient Safety Tether Switch Check | 48 |
| | Treadmill Power Up Sequence Mode..... | 48 |
| | Loss of Communication with the Host System..... | 48 |
| | Loss of Communication due to Timeout | 48 |
| | Programmable Control Instructions TMX428CP | 50 |
| | TESTING MODE DISPLAY | 50 |
| | MANUAL MODE DISPLAY | 50 |
| | Control Panel Display | 51 |
| | Patient Safety Tether:..... | 51 |
| | WORKOUT GRAPHICS | 53 |

| | | |
|----------|--|-----------|
| | MANUAL OPERATION: | 53 |
| | BUILT-IN PROGRAM OPERATION..... | 55 |
| | Pre-Programmed Protocol Workout Data..... | 55 |
| | Pre-Programmed Fitness Workout Data..... | 58 |
| | User Defined Programming..... | 61 |
| 7 | Preventive Maintenance | 62 |
| | Reprocessing Instructions..... | 62 |
| | Daily Maintenance..... | 62 |
| | Weekly Maintenance..... | 62 |
| | Monthly Maintenance..... | 62 |
| | Semiannual Maintenance..... | 63 |
| | Belt Cleaning and Inspection..... | 63 |
| | Running Belt Tracking Adjustment..... | 63 |
| | Running Belt Tension Adjustment..... | 64 |
| | Drive Belt Tension Adjustment..... | 65 |
| | Exterior Care..... | 66 |
| | Elevation Screw Lubrication..... | 66 |
| | Running Deck Maintenance..... | 66 |
| 8 | Troubleshooting | 68 |
| | Power Switch Will Not Illuminate..... | 68 |
| | Facility Circuit Breaker Trips When Powering Up..... | 68 |
| | Treadmill Will Not Start..... | 68 |
| | Running Belt Slips When In Use..... | 69 |
| | Running Belt Is Off-Center..... | 69 |
| | Internal Circuit Breaker Location and Resetting..... | 69 |
| A | Maintenance Log..... | 70 |
| B | Reprocessing Instructions | 72 |

Introduction

Congratulations on the purchase of your new TRACKMASTER® treadmill. These fine machines have been in production since 1977 and represent state-of-the-art design for heavy-duty institutional use. The TRACKMASTER® treadmill has gained worldwide recognition as one of the best and most dependable treadmills on the market. As a result, TRACKMASTER® has thousands of successful installations internationally.

This document describes the TMX428 and TMX428CP treadmills also referred to as the “system”, “device”, or “product”. The document is intended to be used by clinical professionals.

This chapter provides general information required for the proper use of the system and this manual. Familiarize yourself with this information before using the system.

This manual covers the installation and operation of your new treadmill. If you have questions, contact your system integrator or TRACKMASTER® dealer. If you need further assistance, please call the TRACKMASTER® Service Support team at (316)-283-3344.

Intended User

This manual is geared towards helping clinical professionals with the operation of the TRACKMASTER® Treadmill. Clinical professionals are expected to have working knowledge of medical procedures, practices, and terminology as required for completing these examinations.

Intended Use

The medical treadmills are intended as stressing devices, by providing motion to patient, to be interfaced with a variety of cardiac and pulmonary stress testing systems. The treadmill is intended to be operated by the physician, therapist, or operator acting under authorization of the physician with training per IFU under the supervision of a physician and / or therapist, with sufficient knowledge of the indications and contraindications. The medical treadmills are intended to be used in a medical facility or wellness center.

Certain models have a control panel to operate the treadmill.

Caution: Treadmill does not provide any kind of medical treatment diagnostic or assessment.

Indications:

- Symptoms suggesting myocardial ischemia
- Acute chest pain in patients excluded for acute coronary syndrome (ACS)
- Recent ACS treated without coronary angiography or incomplete revascularization
- Known CAD with worsening symptoms
- Prior coronary revascularization (patients 5 years or longer after Coronary artery bypass grafting [CABG] or 2 years or less after percutaneous coronary intervention [PCI])
- Vascular heart disease (to assess exercise capacity and need for surgical intervention)
- Certain cardiac arrhythmias to assess chronotropic competence
- Newly diagnosed heart failure or cardiomyopathy

Contraindications:

- Acute myocardial infarction within 2 to 3 days
- Unstable angina not previously stabilized by medical therapy
- Uncontrolled cardiac arrhythmias causing symptoms or hemodynamic compromise
- Symptomatic severe aortic stenosis
- Uncontrolled symptomatic heart failure
- Acute pulmonary embolus or pulmonary infarction
- Severe pulmonary hypertension
- Acute myocarditis or pericarditis or endocarditis
- Acute aortic dissection
- High-grade AV blocks
- Severe hypertension (SBP greater than 200 mm Hg, DBP greater than 110 mm Hg, or both)
- Inability to exercise given extreme obesity or other physical/mental impairment

Regulatory and Safety Information

This section provides information about the safe use and regulatory compliance of this system. Familiarize yourself with this information and read and understand all instructions before attempting to use this system. The system was designed and manufactured to the appropriate medical regulations and controls.

The purchaser is solely responsible for the training, instruction, supervision and safety of all users of the TRACKMASTER® treadmill, and to use it as intended by the manufacturer. This device is intended to be used as a motion appliance to facilitate cardiac or VO₂ medical evaluation.

NOTE: Disregarding the safety information provided in this manual is considered abnormal use of this system and could result in injury, loss of data, and void any existing product warranties.

Reporting of serious incident

Any serious incident that has occurred in relation to the device should be reported to the manufacturer and the competent authority of the Member State in which the user and/or patient is established.

- **To report to manufacturer:**



Email: tmservice@full-vision.com

- Please provide the following information:
 - The model number of the device as stated on its identification plate affixed on the device
 - The serial number of the device
 - Date of incident
 - Description of incident, including any patient or user impact/injury
 - Your contact information (facility, address, contact name, title, and telephone number)

Safety Conventions

A **Hazard** is a source of potential injury to a person, property, or the system.

This manual uses the terms NOTE, CAUTION, and WARNING to point out hazards and to designate a degree or level of seriousness. Familiarize yourself with the following definitions and their significance.

Definition of Safety Conventions

| Convention | Definition |
|----------------|---|
| NOTE | Indicates a potential hazard or unsafe practice, which, if not avoided, could result in loss or destruction of property or data. For example: NOTE: For maximum efficiency, the TRACKMASTER® treadmill must have its own dedicated power outlet. |
| CAUTION | Indicates a potential hazard or unsafe practice, which, if not avoided, could result in moderate or minor injury. For example: CAUTION: Do not use silicone sprays to wax your treadmill deck. Using silicone sprays will void the warranty. Such sprays can bring surface changes that may cause you to slip. |
| WARNING | Indicates a potential hazard or unsafe practice, which, if not avoided, could result in death or serious injury. For example: WARNING: Never open the hood of the TRACKMASTER® treadmill while it is plugged into a power outlet. Line voltage can cause severe injury or death. |

Safety Hazards

WARNING

Before permitting anyone to use the **TMX428** or **TMX428CP**, do the following:

- Warn each user about the risk of falling while the belt is in motion.
- Stress the need for caution.
- Wait until the treadmill belt is moving before stepping onto the belt.
- Demonstrate the proper mounting and dismounting methods.

Mounting methods:

- **Step 1:** Instruct patient to straddle the belt and hold on to the handrails during initialization of the treadmill before starting the test
- **Step 2:** Send start/run command to the treadmill with patient still straddling the belt, wait a few seconds to ensure there is no uncommanded motion
- **Step 3:** Instruct patient to carefully step on the belt while holding on to the handrails, begin walking and continue with the test

Dismounting methods:

- **Step 1:** Slow the running belt to its minimum speed, then stop the belt
- **Step 2:** Instruct patient to carefully step off the belt while holding on to the handrails
- Show each user how to use the device as described in this manual.
- Risk of personal injury – Keep children under the age of 13 away from device.

- Ask each user to perform a supervised "test usage" at minimum belt speed to review and practice usage techniques.
- Serious injury could result from loss of balance or falls. To reduce the possibility of serious injury, carefully observe the following precautions.
- Observe all the precautions listed under "Responsibility of the Customer" on pages 14 & 15 to reduce the possibility of serious injury as a result of falls or loss of balance.

WARNING

Serious injury or death could result from electrical shock. To reduce the possibility of electrical shock, carefully observe the following precautions.

- To disconnect the treadmill, set the power switch to the OFF position, and remove the plug from the outlet. When the power is off, the green light on the power switch is dark.
- Never operate the device with a damaged power cord or plug.
- Power cord should be routed through frame mounted clamp and kept clear of the elevation mechanism.
- Keep the power cord out of traffic areas and away from heated surfaces.
- Never use extension cords.
- Never operate the device when it is wet.
- Never operate the device if it is not operating properly.
- Always unplug the machine before service or maintenance is performed.
- Treadmill should be serviced by authorized technicians only.
- Operator should report any electrical shock when touching the treadmill and discontinue use immediately.
- Never use the treadmill outdoors.
- Immediately discontinue use and unplug the treadmill if you smell the distinctive odor of hot electrical components.

WARNING

Serious injury or death could result from electrical shock occurring during defibrillation. Never allow patient or operators near treadmill during defibrillation.

Portable RF communications equipment (including peripherals such as antenna cables and external antennas) should be used no closer than 30 cm (12 inches) to any part of the treadmill, including cables specified by the manufacturer. Otherwise, degradation of the performance of this equipment could result.

WARNING

Consult your physician prior to using the device to determine your physical readiness and capabilities. Stop exercising immediately and seek medical attention if you experience chest pain, dizziness or shortness of breath or if you experience symptoms of overexertion.

WARNING

Serious injury or death could result from operating the treadmill in the presence of explosive or flammable vapors and antiseptics.

WARNING

The potential for foot crush injury at frontal end of treadmill at lift mechanism (landing gear) when treadmill is descending. Keep feet and hands away from this area at all times.

Potential foot crush injury at rearward side rail, rear of side rail and rear roller exists when treadmill approaches full elevation. Keep feet and hands away from this area at all times.

In order to avoid the risk of electrical shock, this equipment must be connected to the supply grid with a protective earth.

Classification of Medical Device

This device is classified as follows, according to IEC 60601-1:

NOTE: Class A 60601 Emissions 120V 60 Hz (covers only medical/commercial installations).

Class B 60601 Emissions 220V 50/60 Hz (covers all market installations).

Medical Device Classification

| Category | Classification |
|---|--|
| Type of protection against electrical shock | Class I motor operated physical medicine machine. |
| Degree of protection against electrical shocks | Type B external application applied part. |
| Degree of protection against harmful ingress or water | Ordinary equipment (enclosed equipment without protection against ingress of water). |
| Degree of safety of application in the presence of a flammable anesthetic mixture with air or with oxygen or with nitrous oxide | Equipment is not suitable for use in the presence of a flammable anesthetic mixture with air or with oxygen or with nitrous oxide. |
| Method(s) of sterilization or disinfection recommended by the manufacturer | Not applicable |
| Mode of operation | Continuous operation. |

Regulatory and Safety Conformance

TMX428 and TMX428CP meet the following safety and regulatory standards for FDA Class 1 motor operated physical medicine machines. They have been tested and listed by TÜV SÜD America Incorporated, also tested by Intertek Testing Services N.A Inc., and are listed by Engineering Testing Laboratories (ETL). However, the ultimate conformance to IEC 60601-1 is the responsibility of the system integrator when combined with other equipment. Additionally, all motorized equipment is potentially dangerous if used incorrectly. Before using the TMX428 and TMX428CP, follow all precautions listed in this chapter and read the entire Owner's Manual thoroughly. Use the TMX428 and TMX428CP only as described.

NOTE: This equipment has been tested and found to comply with the limits for a Class B digital device, pursuant to part 15 of the FCC Rules. These limits are designed to provide reasonable protection against harmful interference when the equipment is operated in a commercial environment. This equipment generates, uses, and can radiate radio frequency energy and, if not installed and used in accordance with the instruction manual, may cause harmful interference to radio communications.

Operation of this equipment in a residential area is likely to cause harmful interference in which case the user will be required to correct the interference at owner's expense.

Table 1: Guidance and Manufacturer's Declaration – Emissions

The TMX428 Series is intended for use in the electromagnetic environment specified below. The customer or user of the TMX428 Series should ensure that it is used in such an environment.

| Emissions Test | Compliance | Electromagnetic Environment – Guidance |
|----------------------------|------------|--|
| RF Emissions CISPR 11 | Group 1 | The TMX428 Series uses RF energy only for its internal function. Therefore, its RF emissions are very low and are not likely to cause any interference in nearby electronic equipment. |
| RF Emissions CISPR 11 | Class B | The TMX428 Series is suitable for use in all establishments, including domestic, and those directly connected to the public low-voltage power supply network that supplies buildings used for domestic purposes. |
| Harmonics IEC 61000-3-2 | Class A | |
| Flicker IEC 61000-3-3 | Complies | |

Table 2: Guidance and Manufacturer's Declaration – Immunity All ME Equipment and ME Systems

The TMX428 Series is intended for use in the electromagnetic environment specified below. The customer or user of the TMX428 Series should ensure that it is used in such an environment.

| Immunity Test | IEC 60601 Test Level | Compliance Level | Electromagnetic Environment – Guidance |
|---|---|---|--|
| ESD IEC 61000-4-2 | ±6kV Contact ±8kV Air | ±6kV Contact ±8kV Air | Floors should be wood, concrete or ceramic tile. If floors are synthetic, the r/h should be at least 30% |
| EFT IEC 61000-4-4 | ±2kV Mains ±1kV I/Os | ±2kV Mains ±1kV I/Os | Mains power quality should be that of a typical commercial or hospital environment. |
| Surge IEC 61000-4-5 | ±1kV Differential ±2kV Common | ±1kV Differential ±2kV Common | Mains power quality should be that of a typical commercial or hospital environment. |
| Voltage Dips/Dropout IEC 61000-4-11 | >95% Dip for 0.5 Cycle 60% Dip for 5 Cycles 30% Dip for 25 Cycles >95% Dip for 5 Seconds | >95% Dip for 0.5 Cycle 60% Dip for 5 Cycles 30% Dip for 25 Cycles >95% Dip for 5 Seconds | Mains power quality should be that of a typical commercial or hospital environment. If the user of the TMX428 Series requires continued operation during power mains interruptions, it is recommended that the TMX428 Series be powered from an uninterruptible power supply or battery. |
| Power Frequency 50/60Hz Magnetic Field IEC 61000-4-8 | 3A/m | 3A/m | Power frequency magnetic fields should be that of a typical commercial or hospital environment. |

Table 3: Guidance and Manufacturer’s Declaration – Immunity ME Equipment and ME Systems that is NOT Life-supporting

The TMX428 Series is intended for use in the electromagnetic environment specified below. The customer or user of the TMX428 Series should ensure that it is used in such an environment.

| Immunity Test | IEC 60601 Test Level | Compliance Level | Electromagnetic Environment – Guidance |
|---|---|---|--|
| Conducted RF IEC 61000-4-6 Radiated RF IEC 61000-4-3 | 3 Vrms 150 kHz to 80 MHz 3 V/m 80 MHz to 2.5 GHz | (V1)=3Vrms (3V, 6V at ISM + Amateur Frequencies) (E1)=3V/m (3 V/m at 80 - 2,700MHz, AM Modulation 9-28V/m, 385 - 6,000MHz, FM or Digital Modulation) | Portable and mobile communications equipment should be separated from the TMX428 Series by no less than the distances calculated/listed below: $D=(3.5/V1)(\text{Sqrt } P)$ 150kHz to 80MHz $D=(3.5/E1)(\text{Sqrt } P)$ 80 to 800 MHz $D=(7/E1)(\text{Sqrt } P)$ 800 MHz to 2.5 GHz Where P is the max power in watts and D is the recommended separation distance in meters. Field strengths from fixed transmitters, as determined by an electromagnetic site survey, should be less than the compliance levels (V1 and E1). Interference may occur in the vicinity of equipment containing a transmitter. |
| Enclosure Port Immunity to Proximity Magnetic Fields IEC 60601-1-2:2014+A1:2020 ed 4.1 | 134,2 kHz 13,56 MHz | Pulse Modulation 2,1 kHz, 65* A/m Pulse Modulation 50 kHz, 7,5* A/m | The carrier shall be modulated using a 50% duty cycle square wave signal. *r.m.s before modulation is applied. |

Table 4 : Recommended Separation Distances between portable and mobile RF Communications equipment and the TMX428 Series ME Equipment and ME Systems that is NOT Life-supporting

The TMX428 Series is intended for use in the electromagnetic environment in which radiated disturbances are controlled. The customer or user of the TMX428 Series can help prevent electromagnetic interference by maintaining a minimum distance between portable and mobile RF Communications Equipment and the TMX428 Series as recommended below, according to the maximum output power of the communications equipment.

| Max Output Power (Watts) | Separation (m) 150kHz to 80MHz | Separation (m) 80 to 800MHz | Separation (m) 800MHz to 2.5GHz |
|--------------------------|-----------------------------------|--------------------------------|------------------------------------|
| | | | |

| | D=(3.5/V1) (Sqrt P) | D=(3.5/E1) (Sqrt P) | D=(7/E1) (Sqrt P) |
|------|----------------------------|----------------------------|--------------------------|
| 0.01 | 0.11667 | 0.11667 | 0.23333 |
| 0.1 | 0.36894 | 0.36894 | 0.73785 |
| 1 | 1.1667 | 1.1667 | 2.3333 |
| 10 | 3.6894 | 3.6894 | 7.3785 |
| 100 | 11.667 | 11.667 | 23.333 |

Responsibility of the Manufacturer

Full-Vision Inc. is responsible for the effects of safety, reliability, and performance of the treadmill only if the following conditions are met:

- Assembly operations, extensions, readjustments, modifications, or repairs are carried out by authorized personnel.
- The electrical installation of the relevant room complies with the requirements of the appropriate local, state, and other government regulations.
- The equipment is used in accordance with the instructions for use.

Responsibility of the Customer

The customer is responsible for providing appropriate desks, chairs, electrical wall outlets, network connections, analog phone lines, and locating any of the system components described in this manual in compliance with all local, state, and national codes.

The customer is solely responsible for the training, instruction, supervision and safety of all users of the **TMX428** and **TMX428CP**, and to use it as intended by the manufacturer. This device is intended to be used as a motion appliance to facilitate cardiac or VO₂ medical evaluation.

- Read this Operator's Manual before operating the **TMX428** and **TMX428CP**.
- Assist in off-loading the patient in the event of abnormal or unexpected operation of the treadmill.
- If the treadmill is not responding properly, stop the treadmill, assist in removing the patient off the running belt, unplug the treadmill power supply, and seek factory authorized repair before attempting to restart the treadmill.
- Never allow children or pets near the machine without qualified adult supervision.
- Note the location of stop and/or emergency stop controls and their operation before starting a test or workout.
- The Patient must always wear the Patient Safety Tether lanyard while operating the **TMX428** and **TMX428CP**.



- In the event the patient falls and the Patient Safety Tether lanyard fails to disengage, use the Emergency Stop Button on the Treadmill to stop the treadmill as this disengages the motor and allows the treadmill to freewheel to a stop
- **THIS DEVICE IS NOT** intended for use by persons with reduced physical, sensory or mental capabilities, or lack of experience and knowledge unless they have been given supervision or instruction concerning use of the appliance by a person responsible for their safety.

- Verify the Patient and Operator understands how to stop the machine in the event of malfunction or emergency.
- Patient should not wear loose fitting nylon material when exercising on this treadmill to avoid generating Electrostatic Discharge.
- Never attempt to remove any article of clothing while the running belt is moving.
- All persons on and around the treadmill must wear enclosed, protective footwear. Shoelaces must be tight and not drape as to cause a trip or catch hazard. Sandals, flip flops, slippers and the like are not considered enclosed, protective footwear.
- Walk in the center of the running belt. Contact with the side rail and the moving belt could cause injury.
- Place the treadmill on a hard, level and unobstructed surface. See Chapter 5 of this manual.
- Check input power cord connection and location for hazardous pinch points before use.
- Check input communications cord connection (if equipped) for proper interface with all equipment.
- Keep all cords clear of patient to avoid trip hazards.
- Never attempt to remove the motor pan hood or do electrical repairs yourself. Repairs should only be done by a factory authorized repair provider.
- Always unplug the **TMX428** and **TMX428CP** when servicing, inspecting or cleaning the treadmill.
- Routinely inspect the treadmill for loose parts.
- Inspect handrails and ensure they will support the patient properly.
- Always start the running belt at its slowest speed before starting the patient test.
- Always slow the running belt to its minimum speed before stopping.
- Keep hands, feet, and clothing away from any moving parts.
- Verify no one is near the elevation mechanism before operating. Never put any part of the body under any part of a running treadmill.
- Never drop or insert objects into any opening.
- Never drape garments, hook-up leads, or other equipment over the side rails or drop objects on the belt while the **TMX428** and **TMX428CP** is running.
- Do not allow moisture or oils to accumulate on equipment, creating a slip hazard.

Product and Package Information

This section describes the location of the labels used on your device and its packaging. It also describes the symbols used on the labels.









Symbols







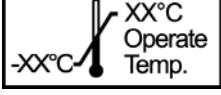
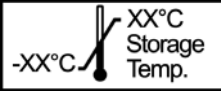

The following symbols may appear on the device or its packaging. Familiarity with these symbols assists in the safe use and disposal of the equipment. For equipment symbols not shown, refer to the original equipment manufacturers (OEM) manuals.





Symbols are used to convey warnings, cautions, prohibitions, mandatory actions, or information. Any hazard symbols on your device or packaging with markings in color indicates there is certain danger and is a warning. Any hazard symbols on your device or packaging that is in black and white indicates a potential hazard and is a caution.

Symbols Glossary

| Symbol | Description/Definition |
|---|---|
|  | Catalog or Orderable Part Number Indicates the manufacturer's catalog or part number. |

| Symbol | Description/Definition |
|--|--|
|  REF ABC123 | Catalog or Orderable Part Number Indicates the manufacturer's catalog or part number. |
|  SN ABC123 | Serial Number Indicates the manufacturer's serial number. |
| MANUFACTURED BY:  YYYY-MM-DD | Manufacturer Name, Address and Manufacturing (Year-Month-Date) Indicates the name and address for the manufacturer of this device. |
|  | CAUTION: CONSULT ACCOMPANYING DOCUMENTS - There may be specific warnings or precautions associated with the device that are not otherwise found on the label. Consult the accompanying documentation for more information about safely using this device. |
|  | CAUTION: ELECTRIC SHOCK - Indicates the presence of hazardous energy circuits or electric shock hazards. To reduce the risk of electric shock hazards, do not open this enclosure. Refer servicing to qualified personnel. |
|  | Reading of the Owner's Manual is mandatory. |
|  | Elevation incline / decline adjustment, TMX428CP Only |
|  | Running belt speed adjustment, TMX428CP Only |
|  | Operate Temperature Limit Indicates the maximum temperature to Operating Temperature of device. |
|  | Storage Temperature Limits Indicates the upper and lower temperature limitations for the transportation and handling of this package. |

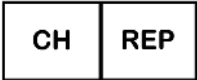
| Symbol | Description/Definition |
|---|--|
|  | <p>Humidity Limits</p> <p>Indicates the upper and lower Non-Condensing Humidity limitations for the transportation, handling of this package and Operating of device.</p> |
|  | <p>This equipment complies with the EU WEEE marking requirement for proper disposal of electrical and electronic waste in accordance with the European Directive. This directive calls for separation and recovery or reuse of used electrical or electronic equipment upon end of life EEE disposal.</p> <p>The TRACKMASTER® must not be disposed of as unsorted municipal waste. Electrical or electronic components must be collected separately and disposed of in accordance with your local requirements and sources. The EEE program minimizes any potential effects on the environment and user health by eliminating the potential presence of hazardous substances in the waste stream. Customers should contact their local authorities or TRACKMASTER® Distributor for guidance in complying with the directive.</p> |
|  | <p>Keep Dry</p> <p>Indicates that you need to keep the container away from rain and other sources of moisture.</p> |
|  | <p>CE Mark</p> <p>Indicates the device or product conforms to applicable EU (European Union) directives.</p> |
|  | <p>Electrical Testing Laboratories</p> <p>Indicates the device or product has been tested by an accredited third-party testing laboratory and meets applicable safety standards for sale and distribution within North America.</p> <p>Traditional and Control Panel models are marked separately.</p> |
|  | <p>Protective earth (ground).</p> |
|  | <p>Alternating current.</p> |
|  | <p>Device is suitable for the external application of the type “B” applied parts.</p> |
|  | <p>Unique Device Identification is a unique marking of the medical device</p> |

| Symbol | Description/Definition |
|---|--|
|  | Follow operating instructions |
|  | Medical device |
|  | Authorized Representative In European Union (Regulatory affairs only). |
|  | Authorized Representative In Switzerland |
|  | United Kingdom Responsible Person |
|  | Importer: Indicates the entity importing the medical device into the locale. |

Label Locations

This section identifies the labels and their locations on the product and packaging.

TMX428 & TMX428CP

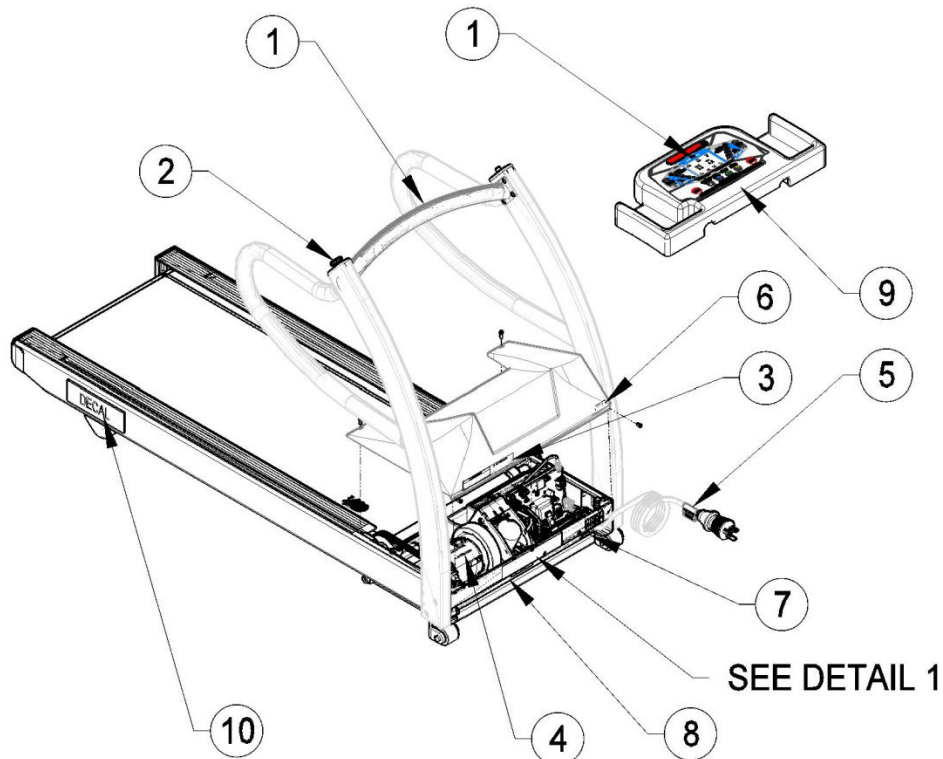



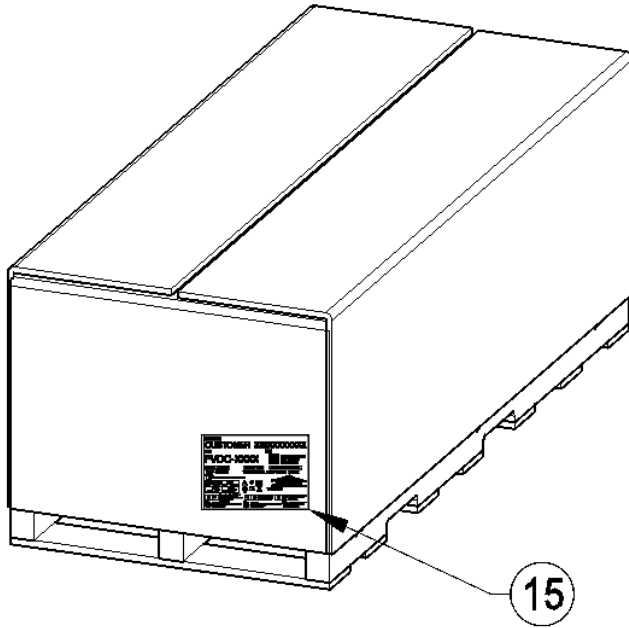



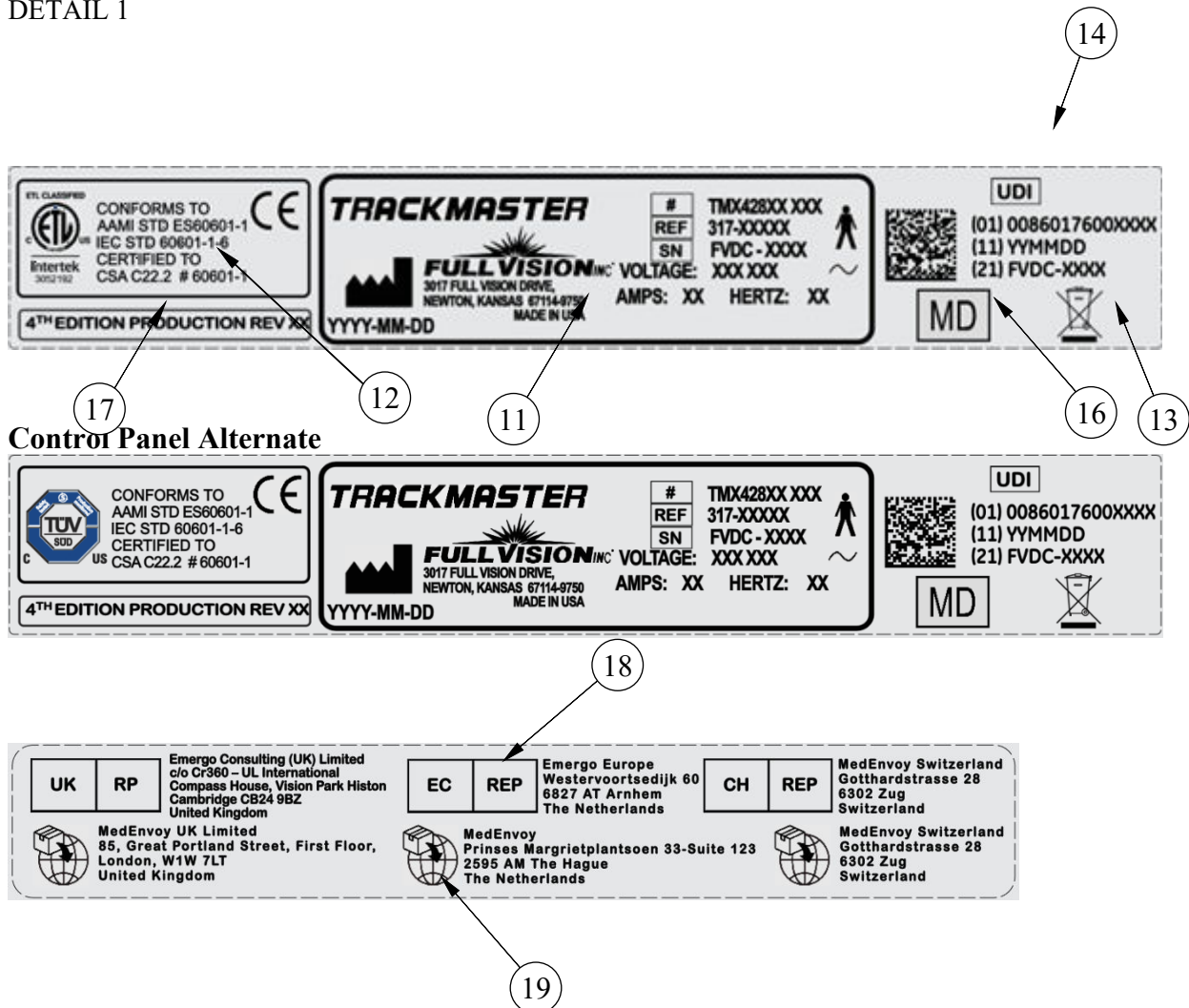

Shipping TMX428 & TMX428CP



DETAIL 1

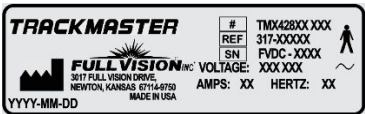
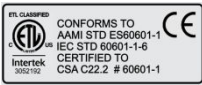

| Item | Label | Location | Description |
|------|---|--|--|
| 1 |  | TMX428 on center handrail TMX428CP center console | Identifies Reading of the Owner's Manual |
| 2 |  | Stop on RH or LH end cap on handrail | Identifies E-Stop |
| 3 |  | Front of the device on the hood | Identifies the Caution Electrical shock hazard |
| 4 |  | On the motor | Identifies the Caution Electrical shock hazard |
| 5 |  | On the Power Cord | Identifies DC Hi-Pot Caution |
| 6 |  | Front of the device on the hood | Identifies Master Power switch. |
| 7 |  | Front of device | Identifies Power Off (disconnection form mains) and Power On (connection to the mains) |
| 8 |  | Front of device | Identifies the location for the RS232 & USB connection point. |
| 9 |  | TMX428CP Front of control panel. | Identifies Warning-Risk of injury- Keep children under the age of 13 away from machine. |
| 10 | Customer Decal | On side channel Right & Left position above rear foot. | Identifies Customer LOGO |
| 11 |  | Front of device | Identifies the Product Model |
| 12 |  | Front of device | Identifies Listing Standards |

| | | | |
|----|--|---|--|
| | | | |
| 13 | | Front of device | Contains the European Union disposal requirements |
| 14 | | Front of the device on motor pan & on Shipping label. | Identifies Unique Device Identifier <ul style="list-style-type: none"> • (01) GTIN Number • (11) Manufacture Date • (21) Serial Number |
| 15 | | On shipping container. | Identifies the following information for shipping: <ul style="list-style-type: none"> • Customer • Model Number • Revision • Serial Number • Storage conditions • Regulatory Compliance • Country of origin • Representative information • Importer information • eIFU website access |
| 16 | | Front of device | Identifies Medical Device |
| 17 | | Front of device | Identifies 4th Edition Production and current revision control. |
| 18 | | Front of device | Identifies Economic Operator |
| 19 | | Front of device | Identifies Importer |

Serial Decal Information

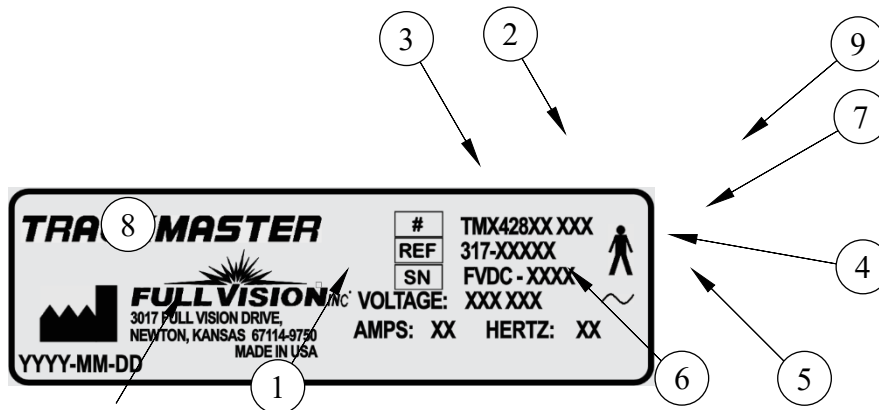

Serial Decal Format

| Item | Name | Description |
|------|-------------------|---|
| 1 | Manufacturer | Full Vision Inc. |
| 2 | Model Number | Identifies model of treadmill |
| 3 | Part Number | Manufacturers part number |
| 4 | Voltage | Specifies operating voltage of treadmill |
| 5 | Hertz | Specifies the electrical hertz of treadmill |
| 6 | Amps | Specifies amperage of treadmill |
| 7 | Serial Number | Manufacturers assigned serial number |
| 8 | Manufacturer Date | Manufacturers date code |
| 9 | Type B Equipment | Device is suitable for the external application of type "B" applied parts |

Service Information

This section provides information pertaining to the maintenance and servicing of the system. Familiarize yourself with this information before requesting service from Full Vision or its authorized representatives.

Service Requirements

Failure on the part of the responsible individual, hospital, or institution using this equipment to implement a satisfactory maintenance schedule may cause undue equipment failure and possible safety hazards.

Regular maintenance, irrespective of usage, is essential to ensure that the components of this system are always functional when required.

Warranty Information

This device is considered Full Vision-supplied hardware. Only authorized service personnel should service the device. Any unauthorized attempt to repair equipment under

warranty voids that warranty. It is the user's responsibility to report the need for service to Full Vision or to one of their authorized agents.

Manual Information

This section provides information for the correct use of this manual. Keep this manual with the equipment at all times and periodically review it.

Manual Purpose

This manual provides information necessary for the configuration and safe operation of this equipment in accordance with its function and intended use. It is not intended as a replacement for, but a supplement to, thorough product training. Keep it with the equipment at all times. Additional manuals may be ordered by contacting Full Vision.

Refer to the service manual for technical information related to the maintenance and repair of the equipment.

Related Documents

The following documents are referenced in this manual and provide additional information that may be helpful in the installation, configuration, maintenance, and use of this product.

| Part Number | Title |
|-------------|-----------------------------|
| 317-160-406 | TMX428 TMX58 Service Manual |

Training

This manual is intended as a supplement to, not a substitute for, thorough product training. If you have not received training on the use of the system, you should request training assistance from your TRACKMASTER® dealer.

If you need further assistance, please call the TRACKMASTER® Service Support team at (316)-283-3344.

Specifications

Directional Orientation

References to left, right, front, and rear assume that you are standing on the treadmill (TMX428), facing the control console (TMX428CP). All parts listed below are considered Patient Applied Parts except where noted.

Essential Performance: Under normal power supply conditions, the treadmill continues to perform its intended operation at the set speed and set elevation. This is unless a change is commanded by a Host Device, Control Panel, or otherwise interrupted by the user through the Emergency Stop Button or the Tether Switch

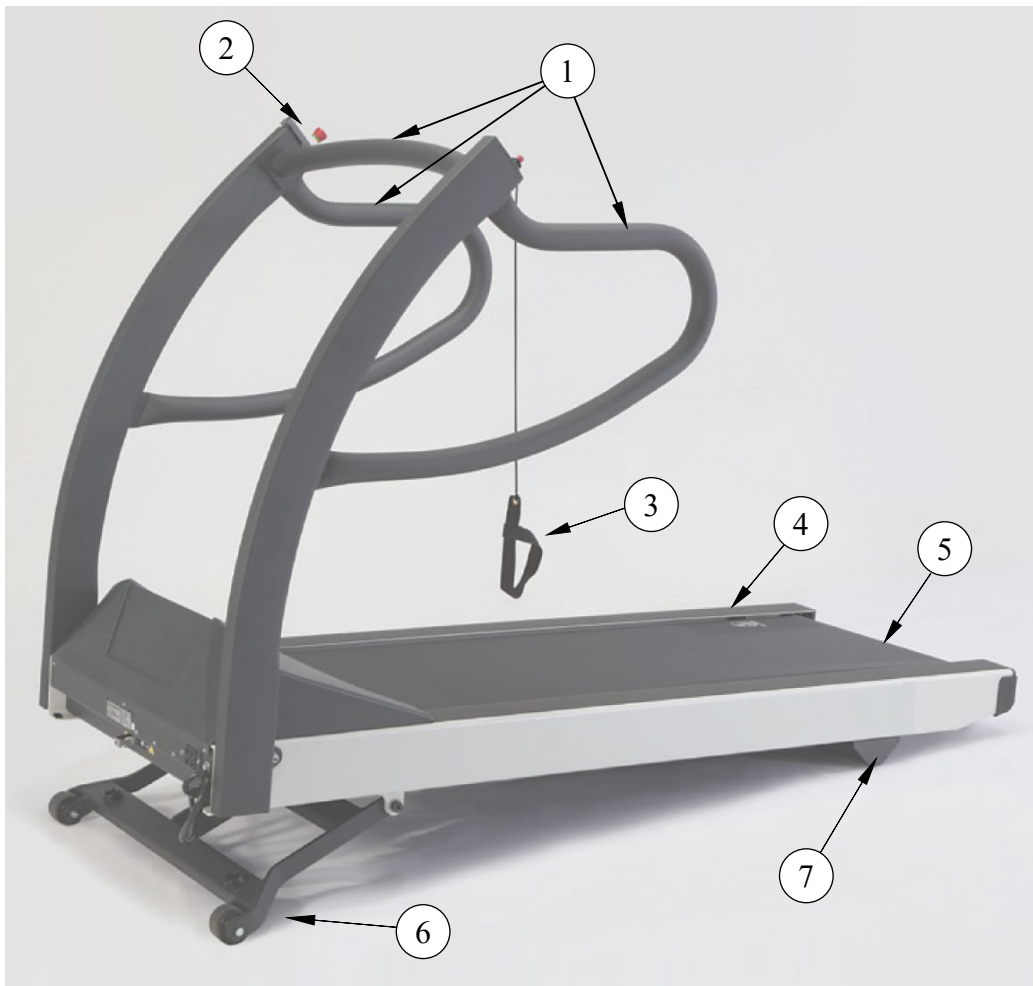

| Item | Description |
|------|---|
| 1 | Patient Grab Rails |
| 2 | Emergency Stop Button |
| 3 | Patient Safety Tether- Wrist Strap Tether or Magnetic Tether Clip |
| 4 | Side Rail |
| 5 | Running Belt |

| | |
|---|---|
| 6 | Elevation Landing Gear (Non-Applied Part) |
| 7 | Rear Foot (Non-Applied Part) |

Safety Systems

- Dual comparative speed sensors
- Auto runaway shutdown
- Auto communication loss shutdown
- Manual twist lock Emergency Stop button
- Manual Patient Safety Tether
- Braking system for safe patient offloading
- Fire rated motor pan hood enclosure



TMX428CP Programmable Control

Treadmill

- Patient weight capacity 500 lb., 227 kg
- All steel construction with baked powder-coat finish
- Treadmill net weight: 425 lb., 193 kg

Drive System

- Heavy-duty 4-peak hp. brushless, DC servo motor
- 110-120VAC, 1-phase, 60 Hz, 20-amp power supply (standard)
- 200-240VAC, 1-phase, 50-60 Hz, 15-amp power supply (optional)
- 220 VAC, Split phase, 50-60 Hz, 15-amp power supply (optional-US Configuration)

Speed Range

- 0.1 to 15.0 mph, 0.2 to 24.0 km/h, self-calibrating and adjustable in 0.1 mph, 0.1 km/h increments.

NOTE: The 220VAC maximum speed (15.0 mph/24.0 km/h) will deteriorate at lower voltages (210VAC or below).

Incline Range

- 0 to 25%, 0.5% incremental movements, self-calibrating.

Running Surface

- 22in. x 63in. 56cm x 160cm
- MasterTrack[®] running belt tracking system
- Cushioned running deck absorbs shock of foot falls
- Self-lubricated and reversible running deck
- Step up height (7 inches., 18cm from floor)

Communication Ports

- RS232 Female Serial port
- USB 1.0 “B” port

Floor Surface Footprint

- 33in. x 78.5 in., 84cm x 200cm level surface. (See Location Chapter 5.)

Operating and Storage Condition Recommendations

- Operating Temperature Range: 4.5° to +38° C (+40° to +85° F)
- Storage Temperature Range: -40° to +70° C (-40° to +158° F)
- Operating and Storage Relative Humidity Range: 10% - 90%, non-condensing
- Altitude: -50 to 5,280 feet, or about -15 to 1609 meters.

3

Power Requirements

The TMX428 110V and TMX428CP 110V are designed to operate on a dedicated 110-120 VAC 20-amp power supply. The TMX428 220V and TMX428CP 220V are designed to operate on a dedicated 220/240 VAC 15-amp. Make sure that the treadmill is connected to an outlet that looks like the following illustration.

This product is equipped with a three-wire grounding-type plug. The plug will only fit into a grounding-type outlet. This safety feature must not be disabled. Contact a qualified electrician if you are unable to insert the plug into your outlet, or uncertain if the outlet meets local electrical codes. Polarized outlets such as NEMA 5-20 and CEE7/7 must be verified for proper polarity configuration before plugging in the device. Incorrect polarization of the outlet could cause failure of onboard electrical components or cause electrical shock. Proper grounding is necessary for the equipment to meet acceptable current leakage standards consistent with the standards to which it was certified.



110-120 VAC
NEMA 5-20R
Single Phase



220/240 VAC
NEMA 6-15R
Split Phase



230 VAC
AS/NZS 3112
Option



220/240 VAC
CEE 7/7 EURO
Option



250 VAC
Type N BRAZIL
Option

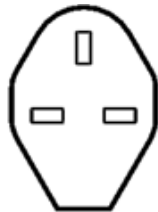

230 VAC
BS1363
Option

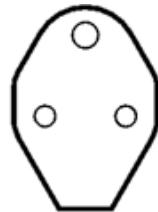

240 VAC
BS546 3 PIN
Option

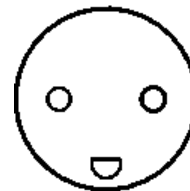

250 VAC
Type K DANISH
Option



240 VAC
GB 1002
Option

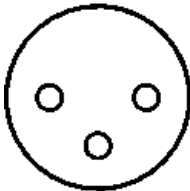

250 VAC
Type H ISRAEL
Option

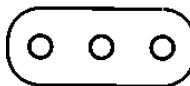

250 VAC
Type L ITALY
Option

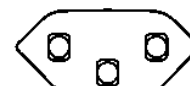

250 VAC
Type J SWISS
Option

WARNING

TRACKMASTER® treadmills must be grounded to reduce the risk of electrical shock. If a malfunction occurs, earth grounding provides a path of least resistance for an electric current. Ungrounded connections must not be used.

No other equipment may be used on the electrical circuit with the device. Do not use extension cords. Using a shared or unreliable circuit can also cause the device to unexpectedly shut off, potentially resulting in injury to the patient.

Ensure the master power switch is in the off position before plugging in the device. A power surge could damage the sophisticated electronic system of the treadmill.

NOTE: Maximum length of power cord should not exceed 10 Feet or 3.05 Meters. Replacement Power Cords need to be ordered through the manufacturer of the operating equipment.

WARNING

Use of this equipment adjacent to or stacked with other equipment should be avoided because it could result in improper operation. If such use is necessary, this equipment and the other equipment should be observed to verify that they are operating normally.

WARNING

Only use accessories, transducers and cables provided by the manufacturer of the equipment. Using alternative non supplied accessories of the components listed above could result in increased electromagnetic emissions or decreased electromagnetic immunity of the equipment and could result in improper operation.

4

Hi-Pot Test Instructions



This test must only be performed by a qualified electrician.

Your Trackmaster® Treadmill has been Hi-Pot tested at the factory just prior to shipment and found to be within specifications. However, some facilities require Hi Pot test verification before the treadmill is put into service. The following instructions must be followed to prevent permanent damage to the Trackmaster® electronic control system. Failure to follow these instructions will void your warranty.

NEVER USE AN AC HI-POT TESTER ON THIS TREADMILL!

Using an AC Hi-Pot tester will permanently damage the DC motor controller board rendering the treadmill inoperable.

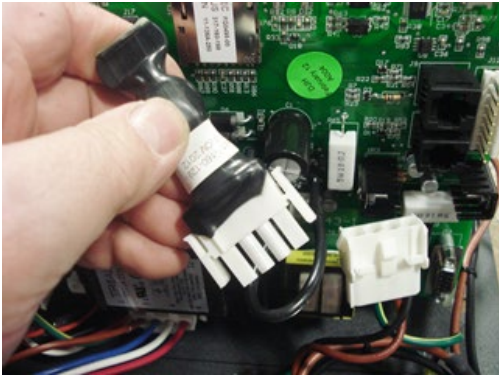
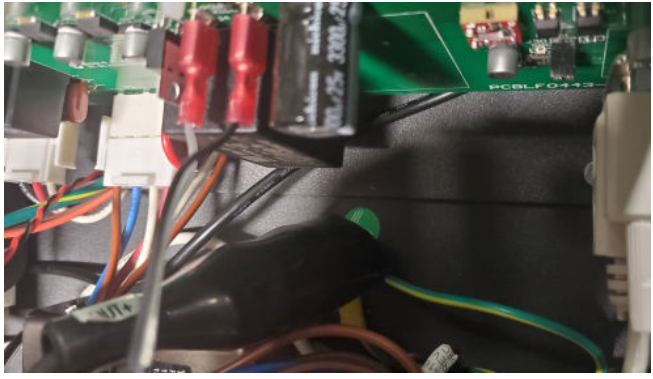
Hi-Pot test instructions for Treadmills

| | |
|---|---|
|  |  |
| <p>1. Unplug the surge suppressor from the main wire harness.</p> | <p>2. Attach DC Hi-Pot tester ground clip to a known chassis ground on the treadmill.</p> |
|  | <p>3. For 110V models: Test at 1.75 KV DC for 60 seconds. This is equivalent to 1240 VAC.</p> <p>4. For 220V models: Test at 2.10 KV DC for 60 seconds. This is equivalent to 1488 VAC.</p> <p>The tester should register a PASS for either test.</p> |

Uncrating, Setup and Assembly

TRACKMASTER® treadmills are shipped fully assembled and packaged in a knock down condition. They are designed to pass through a standard 36" door opening measuring at least 35½". It will be necessary to remove the door from the jam in most cases if the door is not capable of opening fully parallel to door opening. After you have uncrated the treadmill and secured the handrail assembly to the frame, move the treadmill to the area by rolling it on its front wheels

Safe Handling Guidelines

- Do not attempt to move the treadmill with the handrails in the shipping position due to the possibility of cutting the internal wiring. You must either fully secure the handrails in their upright position or secure handrails in the folded position with 3/8-16 bolt. (see uncrating instructions below)
- Lift the end of the bed assembly to a comfortable height, keeping knees bent and back straight as you lift.
- Rotate the treadmill in the direction you want to go (the treadmill will pivot on its wheels) and push forward.
- When you have maneuvered the treadmill into its location, gently lower the end of the bed assembly to the floor.



WARNING

The treadmills weigh 425 lbs. This requires 2 people to safely remove it from the pallet and locate it in the facility.

If you are moving the treadmill over rough surface, such as pavement, use a dolly under front of the treadmill to prevent damage to the wheels and lift mechanism.

Uncrating Instructions

Tools recommended for uncrating

- Safety Knife

1. The treadmill is shipped in a cardboard box with a wood pallet. Cut the 3 nylon straps holding the cardboard cover to the wood pallet.
2. Remove the cardboard box by lifting straight up from one end to clear the treadmill.
3. Carefully cut the zip tie to open the protective plastic bag.
4. Pull the plastic bag down and fold over all 4 corners of the pallet.

NOTE: This will prevent the plastic bag being rolled up into the elevation wheels when removing from wood pallet.

5. Carefully cut the nylon strap securing the treadmill to the pallet.

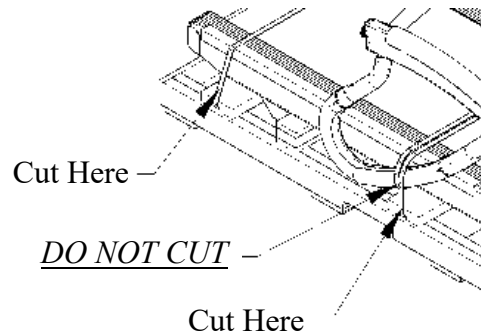

6. DO NOT REMOVE nylon strap for the handrails.

CAUTION: DO NOT REMOVE treadmill from wood pallet with a forklift. The treadmill may slide off fork causing damage to handrails & side channels.

WARNING: The treadmills weigh 425 lbs. This requires 2 people to safely remove it from the pallet and locate it in the facility.

7. Remove from the wood pallet by lifting from the rear of the treadmill and slide off one corner at a time.

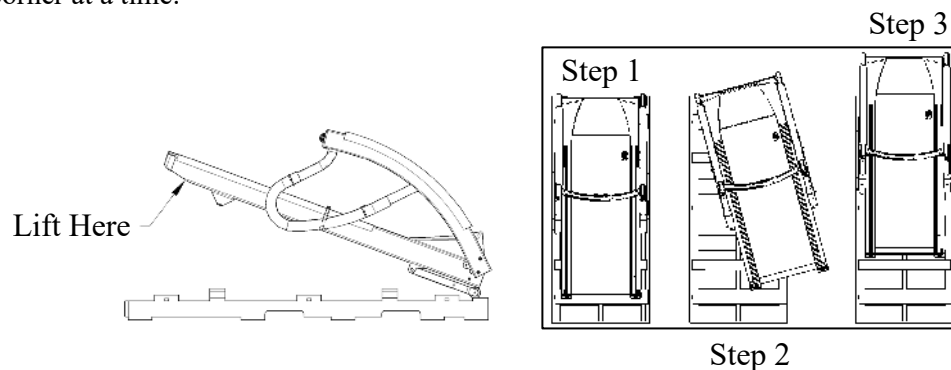

NOTICE

- When moving leave handrails in folded position secured with nylon strap.
 - **NOTE** ▪ Required minimum clearance of 35 1/2" (902mm) to prevent handrail damage.
- At final installation set-up handrails and remove packaging materials.
 - **NOTE** ▪ Removing packaging materials with sharp objects may cause cosmetic damage to treadmill.

8. When moving or relocating the treadmill use a furniture dolly or floor dolly.
9. Position the dolly at the elevation pivot point to provide treadmill balance.

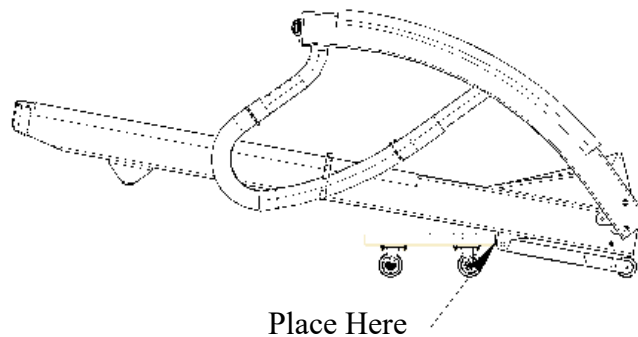

NOTE: When moving to final destination you may experience a narrow passage or doorway. The treadmill can be tipped on the side with handrails in the folded position. This will allow clearance to a minimum of 28" (711mm) to safely pass thru opening.

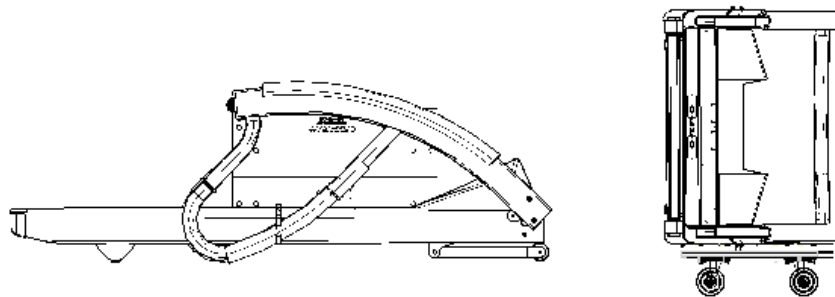

10. Carefully remove the stretch wrap, nylon strap, and protective packaging material.
11. Next step see Initial Setup Instruction.

Initial Setup Instruciton

Tools required for assembly

- 5/16 Allen wrench (supplied)

The treadmill is shipped with the handrails loose, straddling the treadmill frame. It is advised that you secure the handrails in their proper location before removing the treadmill from the base of

the crate. This prevents the internal wires running down the handrail mount to the motor pan from being cut.

1. Swing the handrail assembly into the operating position and insert (2) 3/8-16 bolts and 3/8 lock washer each side and tighten securely.
2. Install (2) plastic caps each side for a finished look. Figure 5-1

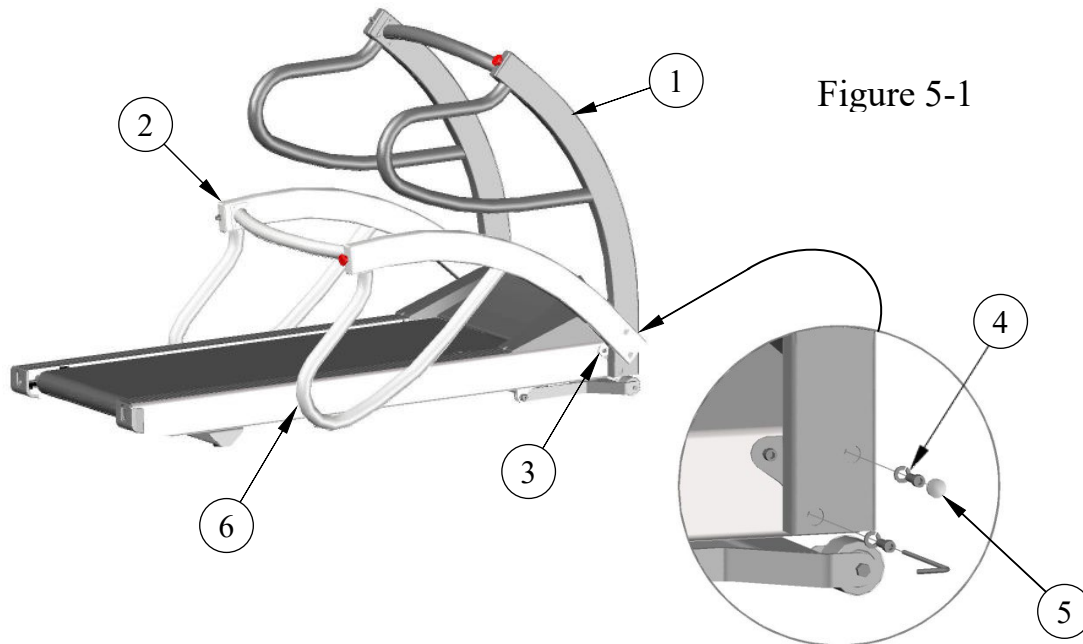

Figure 5-1

| Item | Description |
|------|--|
| 1 | Operating Position |
| 2 | Shipping Position |
| 3 | Pivot Point |
| 4 | Insert (2) washers and bolts each side |
| 5 | Insert (2) caps each side |
| 6 | When folding handrails, apply cardboard between frame and handrail to prevent handrail damage. |

TMX428CP & TMX58 Control Assembly

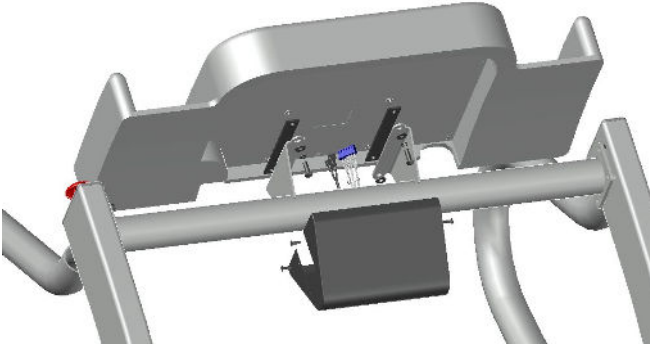

Figure 5-2

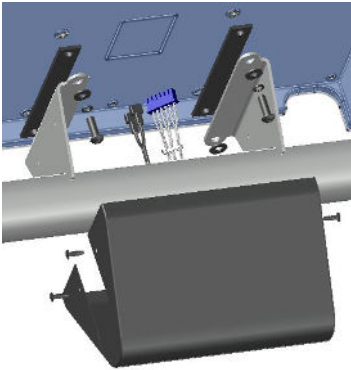

Figure 5-3

3. Figure 5-2 shows the mounting components included with the shipment of the treadmill. The kit contains:

- (4) 1/4-20 bolts
- (1) Black cover
- (4) #10-32 Screws
- (2) Rubber isolators
- (4) Washers

4. Connect electrical 6 pin connection to J8 and quick disconnect to BC4 and BC5 to the back of the LCD Screen console from the connectors within the handrail cross brace.
5. Attach the console to the console supports with the hardware supplied in the order shown in Figure 5-3. Ensure the rubber pads are placed between the steel mounting surface and the back of the console. Tighten bolts evenly.
6. Position the black cover and align the holes in the side of the mount with those in the cover. Secure cover with (4) #10-32 screws.

Location

Place the treadmill on a firm and level hard surface that is free of tile grout lines. The illustration below shows the minimum recommended clearances from the treadmill edges to any obstruction for dismount and safety purposes. Observe that the operator should be stationed by the E-Stop.

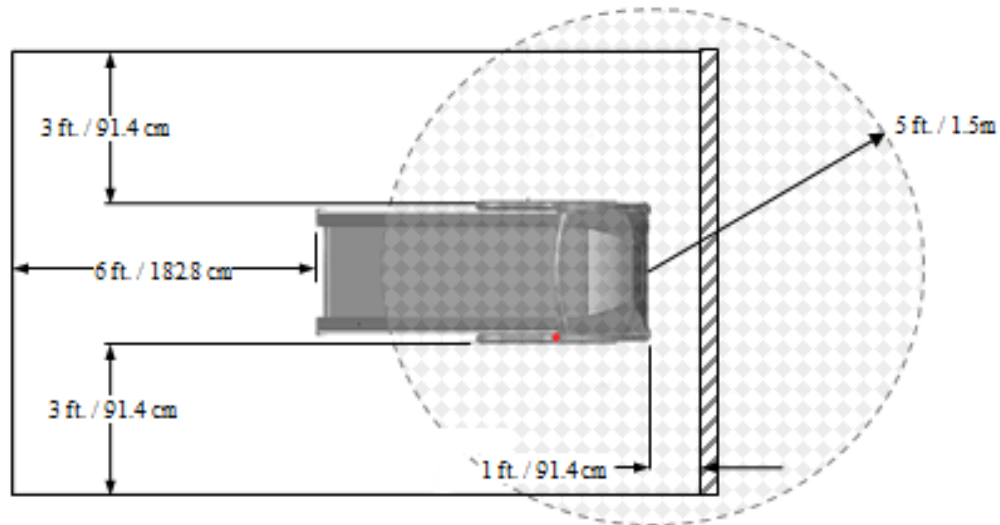

WARNING

The TMX428 and TMX428CP conforms to FCC class B rating for electromagnetic emissions. It is recommended not to place the treadmill closer than 5ft. (1.5m) from sensitive electronic devices within the room or in an adjacent room. If an interference problem occurs, move the treadmill farther away from the sensitive device or relocate either device to another area, or consult with an EMI specialist for ways to shield the room from electromagnetic radiation.

Do not place it on thick or long-pile carpeting. Such carpeting could cause instability or static build-up, and carpet fibers could get caught in the belt and damage the unit.

Ensure that power cords do not cross traffic areas. Exposed power cords can cause a fall, resulting in injury.

Keep it away from sources of moisture, such as spas or fountains. Moisture can cause the electronic circuitry to malfunction.

Final Setup - Running Belt Tracking Adjustment

NOTE: Because this adjustment is not covered under your warranty, it is important that you review these instructions thoroughly before proceeding. Uneven floors accelerate belt misalignment. This situation may require more frequent adjustments to prevent belt damage.

The MasterTrack® Belt Tracking System significantly reduces the need to adjust the belt on your treadmill. However, when you operate your treadmill for the first time, you may need to adjust the tracking of the belt to conform to your floor. You may also need to adjust the tracking if you move the machine to another location. (See **Running Belt Tracking Adjustment**)

Final Setup - Running Belt Tension Adjustment

Your TRACKMASTER® running belt has been pre-tensioned at the factory and run for a minimum of 4 hours prior to shipment. It may, however, be necessary to adjust the belt tension when the treadmill is run in its final location. A loose belt tends to hesitate or stick with a heavy foot plant. If your belt needs tensioning, the adjustment procedure can be found in **(See Running Belt Tension Adjustment**

NOTE: Improper adjustment could cause the treadmill to hesitate and cause a trip and fall hazard. Because this adjustment is not covered under your warranty, it is important that you review these instructions thoroughly before proceeding.

Final Setup - Drive Belt Tension Adjustment

The drive belt tension has been pre-set at the factory to minimize maintenance. If there are indications that the drive belt has stretched and become loose, refer to the Preventative Maintenance Chapter 7 for adjustment procedure. Symptoms of a stretched drive belt could include increased noise.

NOTE: Because this adjustment is not covered under your warranty, it is important that you review these instruction thoroughly before proceeding.

Final Setup - Test Plug Procedure

Each TRACKMASTER® TMX428 Series treadmill includes an RS-232 test plug that enables you to test the operation of the treadmill without the ECG unit attached. The plug is located on the left side of the treadmill secured to the frame by Velcro®. The plug is to be used only for testing the treadmill. Do not stand on or use the treadmill while testing.



Front of Treadmill

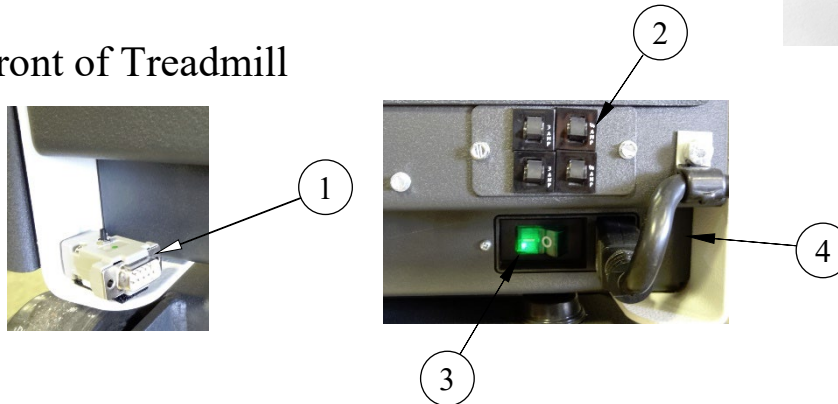

| Item | Description |
|------|--------------------------------|
| 1 | Test plug located on left side |
| 2 | Circuit breaker array |
| 3 | Main power switch |
| 4 | Incoming power cord |

To use the test plug, observe the following procedure:

1. Turn the power "OFF" at the treadmill.
2. Disconnect RS232 or USB interface cable from the treadmill and plug in the test connector.
3. Press and hold the button down on the test connector and turn treadmill power "ON". Continue holding until treadmill begins to elevate.
4. Once the treadmill begins to rise, each push of the button should elevate the treadmill by 5%.
5. Once the treadmill reaches 20% elevation, the next push of the button will start the treadmill running belt.
6. Once the treadmill belt starts, each press of the button should increase speed by 2.5 mph (4 km/h)
7. Once the treadmill reaches 10.0 mph (16 km/h), each push of the button decrease the speed by 2.5 mph (4 km/h) and lower the elevation in 5% increments.
8. Once minimum speed and elevation is reached, the next press of the button should stop the treadmill running belt.

NOTE: Successful completion of the preceding testing procedure ensures that the treadmill is fully functional and responsive to command signals.

NOTE: Unsuccessful completion of the preceding testing procedure indicates a problem with the setup. Call Full Vision or one of their authorized agents to trouble shoot failure of test plug procedure.

9. Remove the test connector and place back on the Velcro® holder.
10. Reconnect the RS232 or USB interface cable from the host computer. You are ready to begin the set-up procedure prescribed by your medical test equipment supplier.

Communication Access Location

The communication ports are located at the very front of the treadmill near the center of the unit.

Two ports are offered with equal communication capability. The standard female RS232 port and a USB Type B port offer connectivity diversification.

You will need to install the appropriate USB driver software on your host computer to communicate with the TRACKMASTER® treadmill. The USB driver is supplied on the provided flash drive. You may download the appropriate driver based upon your computer OS at <http://www.ftdichip.com/Drivers/VCP.htm>. When connecting to the USB port, ensure port configuration is congruent with your software port identification.

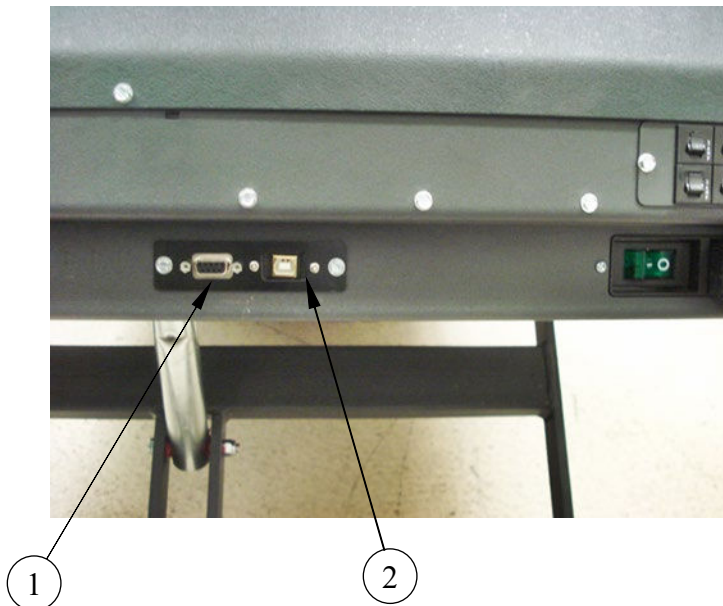

| Item | Description |
|------|---------------------|
| 1 | RS232 Port “Female” |
| 2 | USB “B” Port |

Operating Instructions

Before operating the TMX428 and TMX428CP, familiarize yourself with the following safety control features of the treadmills.

Electrical Safety Tests

The electrical safety of this installation is the responsibility of the customer, not Full Vision, Inc (TRACKMASTER®). In hospitals, contact your in-house biomedical technician, electrician, or technically qualified personnel. Outside of hospital, contact your hospital affiliation of these services.

Before using the treadmill, have qualified personnel perform the test listed below:

- AC line voltage test to verify the power outlet is properly wired.
- Ground continuity test to verify all exposed metal is properly grounded.
- Leakage test to verify the equipment passes all applicable leakage tests.

Your in-house biomedical technician, electrician, or technically qualified personnel can find instruction for performing these tests in the TMX428/TMX428CP Treadmill Service Manual

Operating Controls

The TMX428 treadmill has three operating controls: the power switch, emergency stop switch, and patient safety tether. The power switch is located on the rear panel, the emergency stop is located on the right-hand rail, and the pull tether is located on the left handrail (Optional on opposite side).

Controlling the Treadmill

- Turn the power switch ON (|).
- Use the controlling equipment to start the treadmill, adjust the treadmill speed and grade, proceed through exercise phases, terminate the exercise session, and turn off the treadmill. Refer to the appropriate controlling equipment Operator Manual for instructions.

Power Switch

The power switch controls the AC power to the treadmill. The ON position (|) applies power. The Off position (O) removes power.

Emergency Stop Switch

The emergency stop switch is a safety device for use in emergency situations to stop the treadmill.

CAUTION: When the Emergency Stop Button (ESB) is engaged or pressed in the closed position, the treadmill's running belt will coast to a stop and maintain elevation.

To release the emergency stop switch, turn the push button ¼-turn in clockwise direction or pull to release. The treadmill will return to 0.0% elevation.

NOTE: Use of the Emergency Stop Switch may cause a test interruption.

Emergency Stop Switch Check

NOTE: Verify proper operation of the stop switch assembly every month.

- With the belt moving at a relatively high speed, press the emergency stop switch. The treadmill's running belt will coast to a stop and maintain elevation. To release the emergency stop switch, turn the push button ¼-turn in clockwise direction or pull to release. The treadmill will return to 0.0% elevation.
- If the treadmill is used with a Host Device or for clinical testing, the operator shall be within a distance that provides easy access to the Emergency Stop Switch.

CAUTION: When the Emergency Stop Button (ESB) is engaged or pressed in the closed position the treadmill's running belt will coast to a stop.

- Use the controlling equipment to terminate the exercise session and turn off the treadmill.

Patient Safety Tether Switch

The patient safety tether switch is a safety device for patient safety use in emergency situations to stop the treadmill.

CAUTION: Activation of the patient safety tether while the treadmill is in motion, results in a controlled deceleration rate of 2.5 MPH per second to 0.0 MPH. The elevation is maintained and belt locked at 0.0 MPH for 3 minutes or until power is cycled.

To re-attach the patient safety tether, attach clip or magnet to the original position on the switch. The treadmill will return to 0.0% elevation.

NOTE: Use of the Patient Safety Tether Switch may cause a test interruption.

Wrist Strap Tether Clip Attached



Wrist Strap Tether Clip Detached



Magnetic Tether Attached



Magnetic Tether Detached



Note: The patient safety tether clip needs to be seated for the treadmill to operate as designed and the “Power Up Sequence” completed. If the treadmill receives a start command before reaching zero elevation, the treadmill will reject the start command and will enter into an error mode. In this error mode, the treadmill will be non-responsive to all start commands. You may observe the elevation to change but belt will not start.

You need to perform a main power cycle on the treadmill to come out of the error mode. During the “Power Up Sequence”, there could be a maximum delay of 45 seconds. Pressing the ESB or Patient Safety Tether activation will also serve the purpose of entering the “Power Up Sequence”.

Note: Pressing down on the RED cap of the Patient Safety Tether for greater than 3/4 seconds will result in activation of the Patient Safety Tether. Once the treadmill has reached 0.0 MPH, the treadmill enters into “Power Up Sequence” mode where it goes to the parked position. Wait until the treadmill reaches the parked position as noted above, where failure to allow it to complete the “Power Up Sequence” results in an error mode and the treadmill becomes non-responsive to all start commands.

Note: When resetting the patient safety tether clip or magnet, there may or may not be a break in communication between the host system and the treadmill.

Patient Safety Tether Switch Check

NOTE: Verify proper operation of the patient safety tether switch assembly every month.

- With the belt moving at a relatively high speed, pull the wrist strap or magnet to activate.

CAUTION: Activation of the patient safety tether, the treadmill has a controlled deceleration rate of 2.5 MPH per second to 0.0 MPH and held at 0.0 MPH for 3 minutes or until power cycle.

- The running belt will have resistance preventing the free movement of the running surface. To reattach the patient safety tether, attach clip or magnet to the original position on the switch. The treadmill will return to 0.0% elevation.
- Use the controlling equipment to terminate the exercise session and turn off the treadmill.

Treadmill Power Up Sequence Mode

The treadmill enters into “Power Up Sequence” mode while recovering from certain Stop scenarios.

During this mode the treadmill performs an internal check while returning to its parking position, i.e., zero-elevation point. Ensure NOT to press the “Start” button until the treadmill completes its Power Up Sequence. There is sometimes an audible click that can be heard once the Power Up Sequence is completed.

Loss of Communication with the Host System

The treadmill is equipped with a RS232 or USB port to provide communication with the Stress Host system. Communication with the treadmill can be lost due to multiple factors like interface cable or connector damage, loose connection, cable pinching or entanglement etc. If there is a communication loss while the treadmill is running, the treadmill will gradually decelerate at 0.5mph/sec until stopped. The elevation is maintained, and belt remains locked for 3 mins. The communication between the Host and treadmill is lost and hence an error message will be displayed on the Host system indicating communication loss to the treadmill.

Perform a check on the communication cable, if damaged or fallen lose from its position.

Restoring the cable connection will establish communication with the Host system and the error message on the Host will disappear. Press the “Start” button on the Host system to resume the Exercise test cycle at the speed and elevation as commanded by the Host system.

Loss of Communication due to Timeout

A “Communication timeout” may occur if communication is lost for 2.5 seconds (4 seconds optional) between the Host system and the treadmill. If a communication timeout occurs while the treadmill is running, the treadmill will gradually decelerate at 0.5mph/sec until stopped. The elevation is maintained, and belt remains locked for 3 mins. The Host system may display “No Communication” momentarily, then reestablish communication. Press the “Start” button on the Host system to resume the Exercise test cycle at the speed and elevation as commanded by the Host system.

If following the above does not restart the test cycle, you need to end the test and start a new exercise test. The elevation will go to the parking position. Exercise test cycle will start (belt starts moving) at the speed and elevation as commanded by the Host system.

Programmable Control Instructions TMX428CP

The TRACKMASTER® TMX428CP Programmable Control model is a dual purpose treadmill capable of operating for cardiac stress testing or aVO₂ pulmonary evaluation. The display automatically changes from a blue, full information screen (typically found on fitness treadmills), to a black screen under controlled thru communication. All control buttons on the console are disabled in this mode with the exception of the two stop buttons located at the lower left and lower right of the control. The display will revert back to the full information screen upon closing the communications.

TESTING MODE DISPLAY

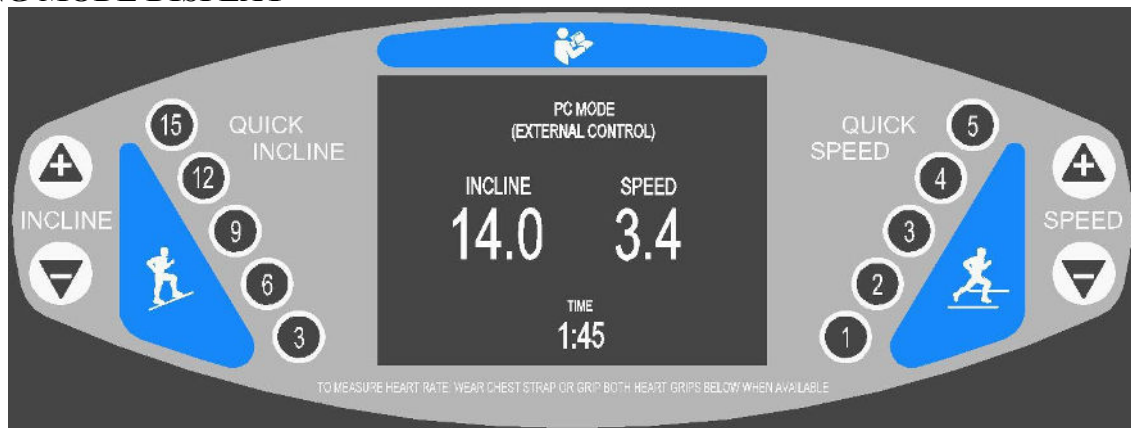

The TRACKMASTER®TMX428CP Control model is a full-featured, stand-alone fitness treadmill suitable for rehabilitation and general fitness applications. Additionally, it comes pre-programmed with 10 workouts, including Pre-Programmed Protocols and Interval Fitness training routines, in addition to 5 possible user defined workouts.

MANUAL MODE DISPLAY

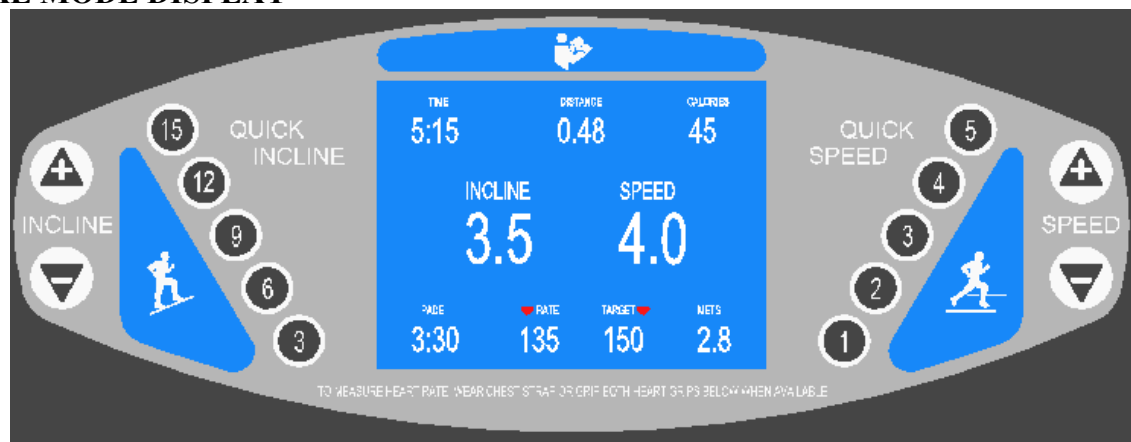

Control Panel Display: The blue display screen in the center of the console provides information on how to begin your workout and provides continuous user performance data throughout the workout session. Additionally, it serves as a user interface allowing optional input of user information when a new workout begins. The screen will prompt the user to input weight, age, and gender so that the onboard computer can calculate a more accurate calorie burn and target heart rate. Heart rate measurement is accessible through the use of the contact grips or by wearing a wireless pulse rate watch or chest strap. The display screen allows the user to simultaneously monitor: time, speed, incline, distance traveled, pace, current heart rate, calories burned and METS.

The performance and feedback information provided on the blue display screen are defined as follows:

Time: The elapsed time of your workout session, beginning with the initial movement of the belt and ending when the stop button is pressed.

Speed: The speed at which the belt is moving. The belt starts at 0.1 MPH. and has a top speed of 15.0 MPH. Belt speed can be increased or decreased in 0.1 MPH increments. This feature is capable of displaying KPH.

Incline: The degree of incline of the walking surface. The starting incline is 0% with a maximum of 25%. The degree of incline can be increased or decreased in .5% increments.

Distance: The distance traveled in miles during the duration of the workout session, beginning with the initial movement of the belt and ending when the stop button are pressed. The distance is measured in .1 of a mile. This feature is capable of displaying in Kilometers.

Heart Rate: The user's current heart rate calculated in beats per minute when wearing a wireless chest strap, wireless watch monitor, or by using the contact grips.

Calories: An approximate calculation of cumulative K-CAL expenditure for the exercise session based on your body weight and the level of difficulty at which you are exercising.

Pace: Displays the number of minutes needed to run one mile or kilometer.

METS: Displays MET level

NOTE: You must attach the Patient Safety Tether lanyard strap to your wrist before pressing any other buttons on the TRACKMASTER® control.

Patient Safety Tether: This switch is located on the console in the lower right hand portion, just right of center. It is used in combination with a lanyard and wrist cuff which is to be worn by the user at all times during the operation of the TRACKMASTER® treadmill. The opposite end of the lanyard has a plastic "C" shaped piece or magnet that engages the Patient Safety Tether, which must be in place for the machine to run. Simply insert the clip on the shaft directly behind the red cap on the switch or place the magnet back on the post. The TRACKMASTER® treadmill is designed to stop all functions upon activation of the Patient Safety Tether. Operation cannot resume until the "C" shaped clip or magnet is returned to its operational position.

Control Panel Button Descriptions:

Start button: The green start button is used to begin a workout session. When a new user steps onto the machine and the startup information is displayed on the screen, pressing the start button will immediately begin a 3 second countdown of the belt start at minimum belt speed. When a user has previously selected a pre-programmed workout, pressing the start button will start the first phase of the program.

Stop buttons: The red hexagon shaped stop buttons are used to end an exercise session. Anytime that it is pressed during a workout session, the running belt will gently come to a stop and be locked into place for 2 minutes or until a new workout session is started. Upon pressing the stop button, the incline of the running deck will decrease to 0 percent and the cumulative user data information will displayed for 60 seconds. To start a new workout session, press the Start button or Program button.

Enter button: The yellow enter button is used to enter the user's weight, age, and gender when prompted by the display screen at the beginning of a workout session as well as entering data when creating or modifying workout programs.

Cool Down button: The blue cool down button will incrementally slow the running belt speed down by 0.1 MPH or KPH and decrease elevation by .5% elevation incrementally over 90 seconds every until the running belt stops and elevation returns to 0% elevation.

Program / Select button: The black program button calls up a list of pre-programmed workouts and is used to select segments of a workout when creating or modifying a workout routine.

Speed Minus "Slower": The triangular speed minus button decreases the speed of the running belt by 0.1 MPH or KPH each time it is pressed while the belt is moving. Pressing and holding the speed minus "slower" button while the belt is moving will decrease the speed of the running belt at an accelerated rate until it is released.

Speed Plus "Faster": The triangular speed faster button increases the speed of the running belt by 0.1 MPH or KPH each time it is pressed while the belt is moving. Pressing and holding the speed plus "faster" button while the belt is moving will increase the speed of the running belt at an accelerated rate until it is released.

Quick Speed: The (5) quick speed buttons will rapidly bring the running belt speed to the speed selected from 1.0 to 5.0 MPH or 1.0 to 5.0 KPH.

Incline Minus: The triangular incline minus button decreases the incline of the walking surface by 0.5 percent each time it is pressed while the running belt is operating. Pressing and holding the incline minus button while the running belt is in motion will increase the rate of the command. However, it may take a few seconds to reach the desired incline that is displayed on the information screen after the button is released.

Incline Plus: The triangular incline plus button increases the incline of the walking surface by .5 percent each time it is pressed while the running belt is operating. Pressing and holding the incline plus button while the running belt is in motion will increase the rate of the command. However, it may take a few seconds to reach the desired incline that is displayed on the information screen after the button is released.

Quick Incline: The (5) quick incline buttons will rapidly bring the running belt surface to the selected incline from 3% to 15%.

WORKOUT GRAPHICS

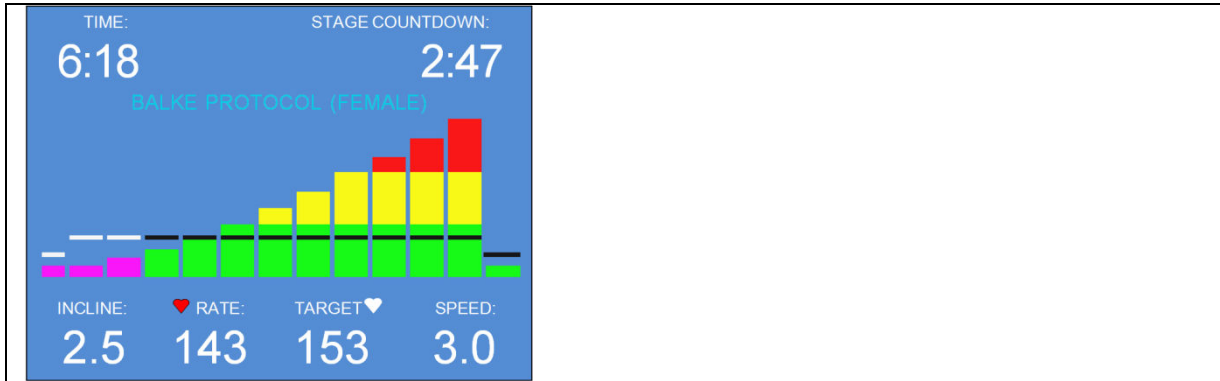

The entire workout is represented in the form of a colored bar graph which depicts increasing workout intensity as well as workout progression and current treadmill settings. These values can be displayed in either Metric or English measurements.

Segments that have been completed will turn to MAGENTA. In the example above, the first three (3) segments of the workout have been completed leaving nine (9) segments yet to complete.

The GREEN portion of the bar represents an incline between 0 and 10%

The YELLOW portion of the bar represents an incline between 10% and 18%.











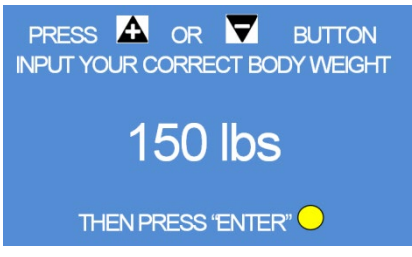



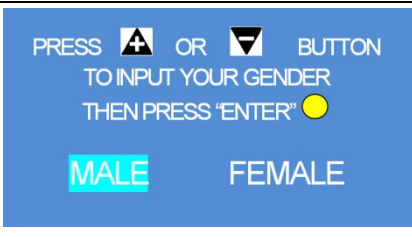

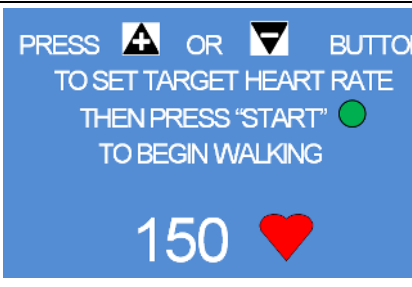

The RED portion of the bar represents an incline from 18% to 25%.

The BLACK horizontal bars represent the running belt speed. They will turn to WHITE when the segment is completed.

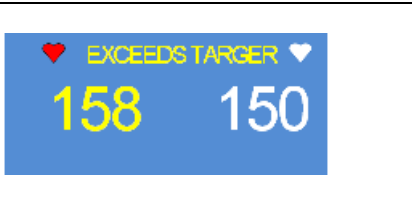
MANUAL OPERATION:

The default start-up screen allows the user to bypass the user data by simply pressing the START button. To enter user data, complete steps 1-16. The user interface screen easily leads the user through the appropriate steps to achieve a desired operation.

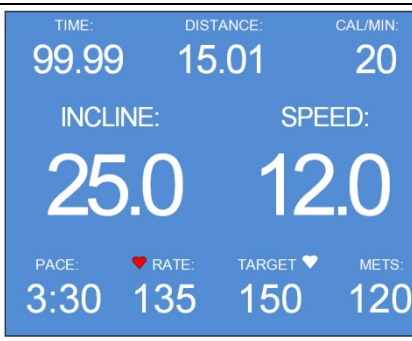
| | |
|--|---|
| <ol style="list-style-type: none"> 1. Press the ENTER button to input user information. 2. Optionally, press the START button to start the treadmill in a non-defined run mode-OR- 3. Press the PROGRAM SELECT button to view and select a Built-In routine. Go to step 15. | <p>PRESS "ENTER" ● TO INPUT USER INFORMATION</p> <p>PRESS "START" ● TO BEGIN EXERCISE ROUTINE</p> <p>PRESS "PROGRAM SELECT" ● TO BEGIN PROGRAM EXERCISE ROUTINE</p> |
| <p>If you opted to input your user information, follow the next 12 steps</p> <ol style="list-style-type: none"> 4. Press the + or – button until the desired age appears on the screen. 5. Press the ENTER button to continue. | <p>PRESS ▲ OR ▼ BUTTON TO INPUT YOUR AGE THEN PRESS "ENTER" ●</p> <p>40</p> |

| | |
|--|---|
| <p>6. Press the + or – button until the desired weight appears on the screen. 7. Press the ENTER button to continue.</p> |  <p>PRESS  OR  BUTTON INPUT YOUR CORRECT BODY WEIGHT</p> <p>150 lbs</p> <p>THEN PRESS 'ENTER' </p> |
| <p>8. Press the + or – button until the correct gender appears on the screen. 9. Press the ENTER button to continue.</p> |  <p>PRESS  OR  BUTTON TO INPUT YOUR GENDER THEN PRESS 'ENTER' </p> <p>MALE FEMALE</p> |
| <p>10. Press the + or – button until the desired heart rate appears on the screen. 11. Press START to begin walking.</p> <p>NOTE: The target heart rate function is only available through the use of a wireless chest strap or pulse rate watch monitoring device.</p> |  <p>PRESS  OR  BUTTON TO SET TARGET HEART RATE THEN PRESS 'START'  TO BEGIN WALKING</p> <p>150 </p> |
| <p>NOTE: If the user exceeds the stated heart rate target, the screen will flash a warning that the target heart rate has been exceeded. The treadmill, however, will not stop. It is the responsibility of the user to take further action.</p> |  <p> EXCEEDS TARGET </p> <p>158 150</p> |
| <p>12. Upon pressing the START button in step 11, the screen will advise that the belt will start in a countdown of 3 as shown at the right.</p> |  <p>THE BELT WILL START IN</p> <p>3</p> |
| <p>13. After the belt begins to move, elevation and speed control is available through the use of the + / - keys as well as the quick speed keys on the console. 14. Press the STOP key to immediately stop your workout or press the COOL DOWN key to slowly decelerate the belt to a stop.</p> |  <p>TIME: 99.99 DISTANCE: 15.01 CAL/MIN: 20</p> <p>INCLINE: 25.0 SPEED: 12.0</p> <p>PACE: 3:30  RATE: 135 TARGET  METS: 120</p> |

BUILT-IN PROGRAM OPERATION

There are 10 pre-programmed workouts within the control. Select from (5) Pre-Programmed protocols and (5) interval training routines. To access these programs, complete the following steps: The following (5) Pre-Programmed Protocols are explained here.

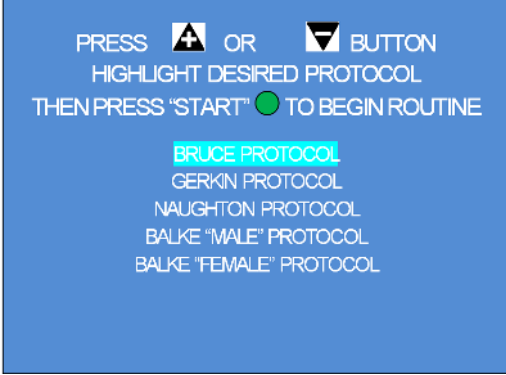
| | |
|---|---|
| <p>15. In Step 3, the user selected the PROGRAM SELECT button to access Built-In program routines. This screen requires the user to select either Pre-Programmed Protocols, Fitness Interval workouts, or to define a custom workout by utilizing the + - buttons. When the desired program is highlighted, press the Yellow Enter button to select. If the user selects Fitness Workouts, go to Step 17. If the user selects the User Defined Program go to Step 19.</p> |  |
| <p>16. Press the + or – button until the desired Protocol is selected. When the desired program is highlighted, press the Green Start button to start routine. The detailed description for each Pre-Programmed Protocol below.</p> |  |

Pre-Programmed Protocol Workout Data

| Bruce Protocol | | | | |
|----------------|-------|-------|-----|---------|
| | Time | Speed | | Incline |
| | | KPM | MPH | |
| Warm-up | 3 min | 2.7 | 1.7 | 0% |
| Stage 1 | 3 min | 2.7 | 1.7 | 10% |
| Stage 2 | 3 min | 4.0 | 2.5 | 12% |
| Stage 3 | 3 min | 5.7 | 3.4 | 14% |
| Stage 4 | 3 min | 6.8 | 4.2 | 16% |
| Stage 5 | 3 min | 8.1 | 5.0 | 18% |
| Stage 6 | 3 min | 8.9 | 5.5 | 20% |
| Stage 7 | 3 min | 8.9 | 6.0 | 22% |
| Cool-down | 3 min | 2.7 | 1.7 | 0% |

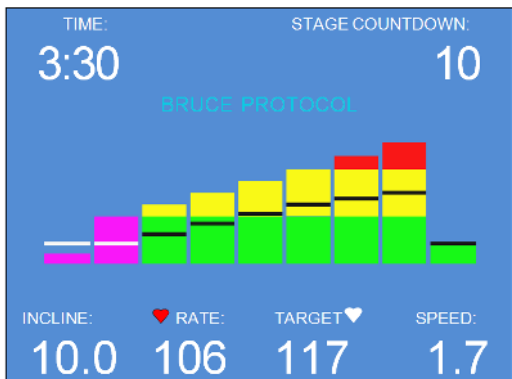

Gerkin Protocol (Firefighter's Test)

| | Time | Speed | | Incline |
|-----------|-------|-------|-----|---------|
| | | KPM | MPH | |
| Warm-up | 3 min | 4.8 | 3.0 | 0% |
| Stage 1 | 1 min | 7.2 | 4.5 | 0% |
| Stage 2 | 1 min | 7.2 | 4.5 | 2% |
| Stage 3 | 1 min | 8.0 | 5.0 | 2% |
| Stage 4 | 1 min | 8.0 | 5.0 | 4% |
| Stage 5 | 1 min | 8.8 | 5.5 | 4% |
| Stage 6 | 1 min | 8.8 | 5.5 | 6% |
| Stage 7 | 1 min | 9.7 | 6.0 | 6% |
| Stage 8 | 1 min | 9.7 | 6.0 | 8% |
| Stage 9 | 1 min | 10.5 | 6.5 | 8% |
| Stage 10 | 1 min | 10.5 | 6.5 | 10% |
| Stage 11 | 1 min | 11.3 | 7.0 | 10% |
| Stage 12 | 1 min | 11.3 | 7.0 | 12% |
| Stage 13 | 1 min | 12.0 | 7.5 | 12% |
| Stage 14 | 1 min | 12.0 | 7.5 | 14% |
| Stage 15 | 1 min | 12.9 | 8.0 | 14% |
| Stage 16 | 1 min | 12.9 | 8.0 | 16% |
| Cool-down | 3 min | 2.7 | 1.7 | 0% |

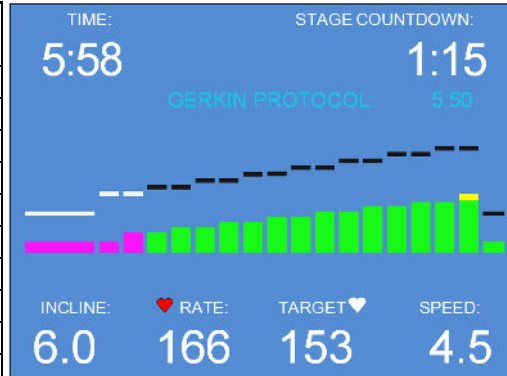

Naughton Protocol

| | Time | Speed | | Incline |
|-----------|-------|-------|-----|---------|
| | | KPM | MPH | |
| Warm-up | 2 min | 1.6 | 1.0 | 0% |
| Stage 1 | 2 min | 3.2 | 2.0 | 0% |
| Stage 2 | 2 min | 3.2 | 2.0 | 3.5% |
| Stage 3 | 2 min | 3.2 | 2.0 | 7.0% |
| Stage 4 | 2 min | 3.2 | 2.0 | 10.5% |
| Stage 5 | 2 min | 3.2 | 2.0 | 14.0% |
| Stage 6 | 2 min | 3.2 | 2.0 | 17.5% |
| Cool-down | 3 min | 1.6 | 1.0 | 0% |

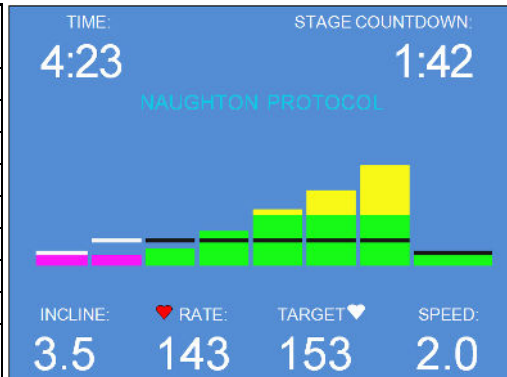

Balke- Male

| | Time | Speed | | Incline |
|-----------|-------|-------|-----|---------|
| | | KPM | MPH | |
| Warm-up | 2 min | 2.7 | 1.7 | 0% |
| Stage 1 | 1 min | 5.3 | 3.3 | 0% |
| Stage 2 | 1 min | 5.3 | 3.3 | 2% |
| Stage 3 | 1 min | 5.3 | 3.3 | 3% |
| Stage 4 | 1 min | 5.3 | 3.3 | 4% |
| Stage 5 | 1 min | 5.3 | 3.3 | 5% |
| Stage 6 | 1 min | 5.3 | 3.3 | 6% |
| Stage 7 | 1 min | 5.3 | 3.3 | 7% |
| Stage 8 | 1 min | 5.3 | 3.3 | 8% |
| Stage 9 | 1 min | 5.3 | 3.3 | 9% |
| Stage 10 | 1 min | 5.3 | 3.3 | 10% |
| Stage 11 | 1 min | 5.3 | 3.3 | 11% |
| Stage 12 | 1 min | 5.3 | 3.3 | 12% |
| Stage 13 | 1 min | 5.3 | 3.3 | 13% |
| Stage 14 | 1 min | 5.3 | 3.3 | 14% |
| Stage 15 | 1 min | 5.3 | 3.3 | 15% |
| Stage 16 | 1 min | 5.3 | 3.3 | 16% |
| Stage 17 | 1 min | 5.3 | 3.3 | 17% |
| Stage 18 | 1 min | 5.3 | 3.3 | 18% |
| Stage 19 | 1 min | 5.3 | 3.3 | 19% |
| Stage 20 | 1 min | 5.3 | 3.3 | 20% |
| Stage 21 | 1 min | 5.3 | 3.3 | 21% |
| Stage 22 | 1 min | 5.3 | 3.3 | 22% |
| stage 23 | 1 min | 5.3 | 3.3 | 23% |
| stage 24 | 1 min | 5.3 | 3.3 | 24% |
| Stage 25 | 1 min | 5.3 | 3.3 | 25% |
| Cool-Down | 3min | 2.7 | 1.7 | 0% |

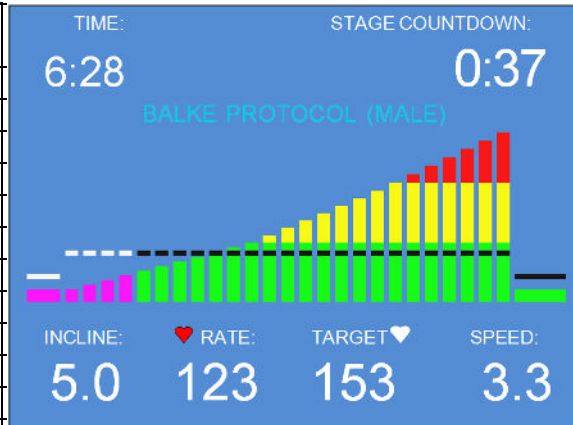

Balke- Female

| | Time | Speed | | Incline |
|-----------|-------|-------|-----|---------|
| | | KPH | MPH | |
| Warm-up | 2 min | 2.7 | 1.7 | 0% |
| Stage 1 | 1 min | 4.8 | 3.0 | 0% |
| Stage 2 | 1 min | 4.8 | 3.0 | 2.5% |
| Stage 3 | 1 min | 4.8 | 3.0 | 5.0% |
| Stage 4 | 1 min | 4.8 | 3.0 | 7.5% |
| Stage 5 | 1 min | 4.8 | 3.0 | 10% |
| Stage 6 | 1 min | 4.8 | 3.0 | 12.5% |
| Stage 7 | 1 min | 4.8 | 3.0 | 15.0% |
| Stage 8 | 1 min | 4.8 | 3.0 | 17.5% |
| Stage 9 | 1 min | 4.8 | 3.0 | 20.0% |
| Stage 10 | 1 min | 4.8 | 3.0 | 22.5% |
| Stage 11 | 1 min | 4.8 | 3.0 | 25.0% |
| Cool-Down | 3min | 2.7 | 1.7 | 0% |

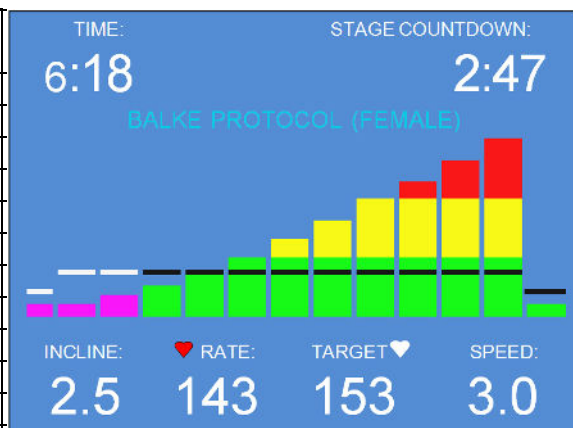

Pre-Programmed Fitness Workout Data

17. To access Pre-Programmed Fitness Workouts, use the + / - key to highlight the selection and press the Yellow Enter button.



18. The screen at the right shows the (5) Fitness workouts the user can choose from. Select the desired Fitness Workout by pressing the + / - button then press the Yellow Enter button to input user information or press the Green Start button to begin workout.

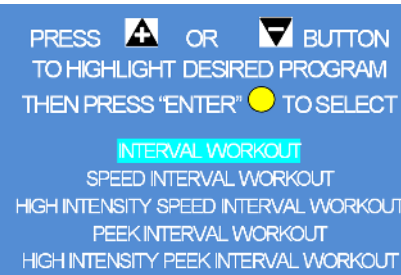

NOTE: Any of the Fitness Interval Training programs can be altered in intensity merely by pressing + / - for belt speed or incline. The control will remember that setting as it transitions from one segment to the next.

INTERVAL WORKOUT

| | Time | Speed | | Incline |
|-----------|---------|-------|-----|---------|
| | | KPH | MPH | |
| Warm-up | 1.5 min | 4.8 | 3.0 | 0% |
| Stage 1 | 1.5 min | 5.6 | 3.5 | 5% |
| Stage 2 | 1.5 min | 4.8 | 3.0 | 2% |
| Stage 3 | 1.5 min | 5.6 | 3.5 | 7% |
| Stage 4 | 1.5 min | 4.8 | 3.0 | 5% |
| Stage 5 | 1.5 min | 5.6 | 3.5 | 9% |
| Stage 6 | 1.5 min | 4.8 | 3.0 | 5% |
| Stage 7 | 1.5 min | 5.6 | 3.5 | 12% |
| Stage 8 | 1.5 min | 4.8 | 3.0 | 5% |
| Stage 9 | 1.5 min | 5.6 | 3.5 | 12% |
| Cool-Down | 3.0 min | 4.8 | 3.0 | 0% |

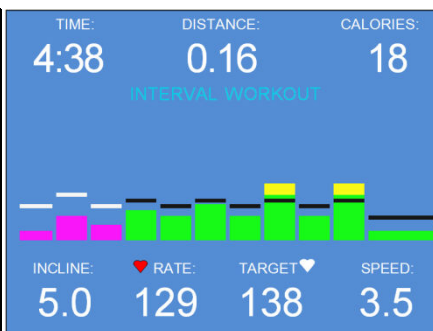

SPEED INTERVAL WORKOUT

| | Time | Speed | | Incline |
|-----------|---------|-------|-----|---------|
| | | KPH | MPH | |
| Warm-up | 1.5 min | 4.0 | 2.5 | 0% |
| Stage 1 | 0.5 min | 6.4 | 4.0 | 0% |
| Stage 2 | 1.5 min | 4.0 | 2.5 | 0% |
| Stage 3 | 0.5 min | 6.4 | 4.0 | 0% |
| Stage 4 | 1.5 min | 4.0 | 2.5 | 0% |
| Stage 5 | 0.5 min | 6.4 | 4.0 | 0% |
| Stage 6 | 1.5 min | 4.0 | 2.5 | 0% |
| Stage 7 | 0.5 min | 6.4 | 4.0 | 0% |
| Stage 8 | 1.5 min | 4.0 | 2.5 | 0% |
| Stage 9 | 0.5 min | 6.4 | 4.0 | 0% |
| Stage 10 | 1.5 min | 4.0 | 2.5 | 0% |
| Stage 11 | 0.5 min | 6.4 | 4.0 | 0% |
| Stage 12 | 1.5 min | 4.0 | 2.5 | 0% |
| Stage 13 | 0.5 min | 6.4 | 4.0 | 0% |
| Stage 14 | 1.0 min | 4.0 | 2.5 | 0% |
| Cool-Down | 3.0 min | 3.2 | 2.0 | 0% |

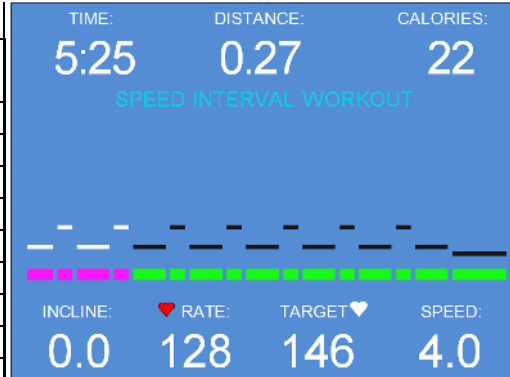

HIGH INTENSITY SPEED INTERVAL WORKOUT

| | Time | Speed | | Incline |
|-----------|---------|-------|-----|---------|
| | | KPH | MPH | |
| Warm-up | 1.5 min | 4.0 | 2.5 | 0% |
| Stage 1 | 1.5 min | 6.4 | 4.0 | 0% |
| Stage 2 | 0.5 min | 4.0 | 2.5 | 0% |
| Stage 3 | 1.5 min | 6.4 | 4.0 | 0% |
| Stage 4 | 0.5 min | 4.0 | 2.5 | 0% |
| Stage 5 | 1.5 min | 6.4 | 4.0 | 0% |
| Stage 6 | 0.5 min | 4.0 | 2.5 | 0% |
| Stage 7 | 1.5 min | 6.4 | 4.0 | 0% |
| Stage 8 | 0.5 min | 4.0 | 2.5 | 0% |
| Stage 9 | 1.5 min | 6.4 | 4.0 | 0% |
| Stage 10 | 0.5 min | 4.0 | 2.5 | 0% |
| Stage 11 | 1.5 min | 6.4 | 4.0 | 0% |
| Stage 12 | 0.5 min | 4.0 | 2.5 | 0% |
| Stage 13 | 1.5 min | 6.4 | 4.0 | 0% |
| Stage 14 | 1.0 min | 4.0 | 2.5 | 0% |
| Cool-Down | 3.0 min | 3.2 | 2.0 | 0% |

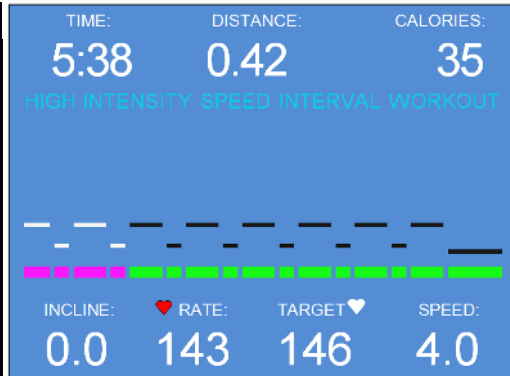

PEAK INTERVAL WORKOUT

| | Time | Speed KPH / MPH | | Incline |
|-----------|---------|--------------------|-----|---------|
| Warm-up | 1.5 min | 4.0 | 2.5 | 0% |
| Stage 1 | 0.5 min | 6.4 | 4.0 | 5% |
| Stage 2 | 1.5 min | 4.0 | 2.5 | 3% |
| Stage 3 | 0.5 min | 6.4 | 4.0 | 5% |
| Stage 4 | 1.5 min | 4.0 | 2.5 | 3% |
| Stage 5 | 0.5 min | 6.4 | 4.0 | 5% |
| Stage 6 | 1.5 min | 4.0 | 2.5 | 3% |
| Stage 7 | 0.5 min | 6.4 | 4.0 | 7% |
| Stage 8 | 1.5 min | 4.0 | 2.5 | 5% |
| Stage 9 | 0.5 min | 6.4 | 4.0 | 9% |
| Stage 10 | 1.5 min | 4.0 | 2.5 | 7% |
| Stage 11 | 0.5 min | 6.4 | 4.0 | 12% |
| Stage 12 | 1.5 min | 4.0 | 2.5 | 10% |
| Stage 13 | 0.5 min | 6.4 | 4.0 | 12% |
| Stage 14 | 1.0 min | 4.0 | 2.5 | 3% |
| Cool-Down | 3.0 min | 3.2 | 2.0 | 0% |

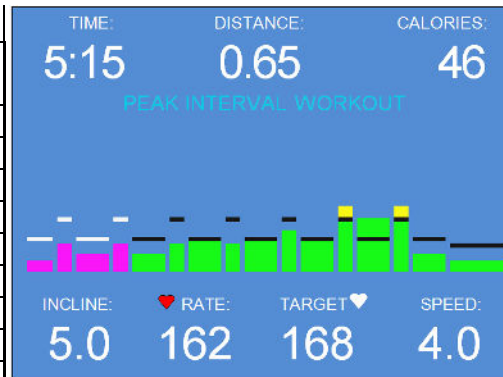

HI INTENSITY PEAK INTERVAL WORKOUT

| | Time | Speed KPM / MPH | | Incline |
|-----------|---------|--------------------|-----|---------|
| Warm-up | 1.5 min | 4.0 | 2.5 | 0% |
| Stage 1 | 1.5 min | 6.4 | 4.0 | 5% |
| Stage 2 | 0.5 min | 4.0 | 2.5 | 3% |
| Stage 3 | 1.5 min | 6.4 | 4.0 | 5% |
| Stage 4 | 0.5 min | 4.0 | 2.5 | 3% |
| Stage 5 | 1.5 min | 6.4 | 4.0 | 5% |
| Stage 6 | 0.5 min | 4.0 | 2.5 | 3% |
| Stage 7 | 1.5 min | 6.4 | 4.0 | 7% |
| Stage 8 | 0.5 min | 4.0 | 2.5 | 5% |
| Stage 9 | 1.5 min | 6.4 | 4.0 | 9% |
| Stage 10 | 0.5 min | 4.0 | 2.5 | 7% |
| Stage 11 | 1.5 min | 6.4 | 4.0 | 12% |
| Stage 12 | 0.5 min | 4.0 | 2.5 | 10% |
| Stage 13 | 1.5 min | 6.4 | 4.0 | 12% |
| Stage 14 | 1.0 min | 4.0 | 2.5 | 3% |
| Cool-Down | 3.0min | 3.2 | 2.0 | 0% |

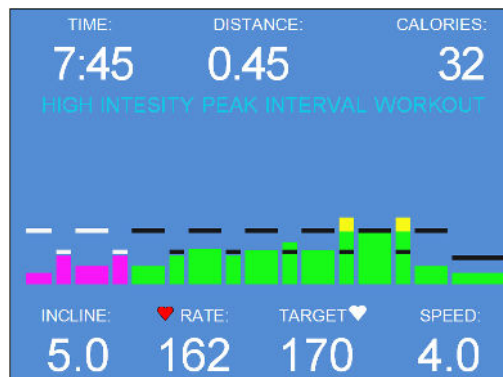

User Defined Programming

19. To access User Defined menu, use the + / - key to highlight the selection and press the Yellow enter button.

NOTE: Any of the User Defined Programs can be altered in intensity merely by pressing + / - for belt speed or incline. The computer will remember that setting as it transitions from one segment to the next.

20. The screen at the right shows the (5) Custom Workouts the user can choose from. The control has room for 10. Select the desired Custom Workout by pressing the + / - button then press the Green Start button to begin or press the Yellow Enter button to modify an existing workout. If no workouts exist and you press the Start button, Screen 21 will appear.

21. Press the + / - buttons to input the variables a field. Make sure your variable value is correct before pressing the Black Program Select button. Upon pressing this button, the cursor will advance to the next variable field. Repeat the steps above for all 3 fields. Press the Green Start button to save the routine.

PRESS  OR  BUTTON
TO HIGHLIGHT DESIRED PROGRAM
THEN PRESS "ENTER" 

PRE-PROGRAMMED PROTOCOLS

FITNESS WORKOUTS

USER DEFINED PROGRAM

PRESS  OR  BUTTON
HIGHLIGHT DESIRED PROGRAM
THEN PRESS "START"  TO BEGIN ROUTINE

CUSTOM WORKOUT 1

CUSTOM WORKOUT 2



CUSTOM WORKOUT 3

CUSTOM WORKOUT 4

CUSTOM WORKOUT 5

TO MODIFY EXISTING PROGRAM

SELECT "ENTER" 

PRESS  OR  BUTTON
TO SET TIME, ELEVATION, SPEED
PRESS "PROGRAM SELECT"  TO
ADVANCE AFTER EACH INPUT

STAGE 1 OF 10

TIME (SECONDS): 000

ELEVATION (% GRADE): 00.0

SPEED (MPH): 00.0

THEN PRESS "START"  TO SAVE

Preventive Maintenance

Regular cleaning and maintenance is essential to keep your TRACKMASTER® treadmill operating at its best for many years. We recommend that you record all maintenance and service in a log (as shown in Appendix A).



CAUTION: Before cleaning the device turn the main power switch to OFF and disconnect the treadmill from its power outlet. Never use wet cleaning materials near a power source: you could suffer an electrical shock.

To preserve the condition of your warranty, make sure that all repair procedures (other than normal maintenance) are performed by an authorized and qualified service provider. Contact customer support with any questions at (316) 283-3344.

Use only TRACKMASTER® replacement parts. Using other parts may void your warranty and may cause your treadmill to malfunction.

NOTE: Replacement Parts need to be ordered through the manufacturer of the operating equipment to ensure BASIC SAFETY and ESSENTIAL PERFORMANCE with regard to ELECTROMAGNETIC DISTURBANCES for the EXPECTED SERVICE LIFE.

Reprocessing Instructions

To reprocess the treadmill between each patient use, follow the reprocessing instructions located in Appendix B.

Daily Maintenance

- Ensure that the treadmill is functioning properly.
- Visual inspection of treadmill and walking belt for damage and wear

Weekly Maintenance

- Vacuum around and under the treadmill. Clean all exposed surfaces with a vacuum cleaner. Avoid moving the treadmill from its original position as moving it will compromise the original belt tracking setting.
- Check running belt tension.
- Observe running belt tracking, correct as required.

Monthly Maintenance

- Inspect and clean the belt.

Semiannual Maintenance

- Evaluate the condition of the deck and belt.
- Adjust the belt to assure proper alignment.
- Check running belt adjustment.
- Check drive belt tension adjustment.
- Clean and lubricate the treadmill elevation screw.
- Clean the interior of the motor electrical enclosure as needed.

NOTE: Use only TRACKMASTER® replacement parts. Using other parts may void your warranty and may cause your treadmill to malfunction.

Belt Cleaning and Inspection

1. Turn treadmill main power switch ON.
2. Start treadmill at 0.5 MPH. With a damp small towel wipe excessive dirt from running belt keeping the towel in the center of the length of the treadmill. Avoid getting the towel near the rear roller.
3. When belt is clean stop treadmill.
4. Inspect running belt for tears or nicks. If damaged, replace the belt.
5. Perform Running Belt Tracking Adjustment and Belt Tension Adjustment.

Running Belt Tracking Adjustment

This procedure requires the following tool:

- ¼" Allen wrench

NOTE: Because this adjustment is not covered under your warranty, it is important that you review these instructions thoroughly before proceeding.

The patented MasterTrack® Belt Tracking System significantly reduces the need to adjust the belt on your treadmill. However, when you operate your treadmill for the first time, you may need to adjust the tracking of the belt to conform to your floor. You may also need to adjust the tracking if you move the machine to another location.

Your running belt should remain centered, although a slight amount of movement to the left or right is normal during use. Do not allow the running belt to travel all the way to either side.

To adjust the belt tracking, do the following:

1. Turn the treadmill's power switch to ON.
2. Increase the speed to 3.0 mph (4.8 km/h).
3. Observe the left side of the running belt as it travels over the rear roller. If the belt runs to the right side of the roller, turn the right bolt 1/8 turn clockwise, and turn the left bolt 1/8 turn counterclockwise.

NOTE: When tightening one side of the belt, loosen the opposite side one-half as much. This procedure provides finer control, with a smaller impact on the belt tension.

Check the belt after 2 minutes, with the treadmill running at approximately 7.0 mph (11.3 km/h). If the belt does not correct itself, continue with slight turns until the belt is in the center of the rear roller. If the belt runs toward the left side of the roller, reverse the adjustments.

NOTE: Uneven floors accelerate belt misalignment. This situation may require more frequent adjustment to prevent belt damage.

Running Belt Tension Adjustment

The running belt may stretch and loosen with regular use. This looseness is noticeable when the belt tends to hesitate or stick. Adjust the tension on the belt by following the procedure and referring to the illustration below.

1. Turn the treadmill's power switch to ON.
2. Start treadmill and increase to 1.0 mph (1.6 km/h).
3. Start walking on the treadmill, grab side handrail and apply pressure with your foot to create resistance on running belt.
4. If running belt hesitates or slips on front drive roller, tighten both tension bolts $\frac{1}{2}$ turn (clockwise).
5. Repeat steps 2 thru 4 until running belt stops slipping.

NOTE: When running belt is too tight, the edge of belt will curl, causing premature running belt failure.

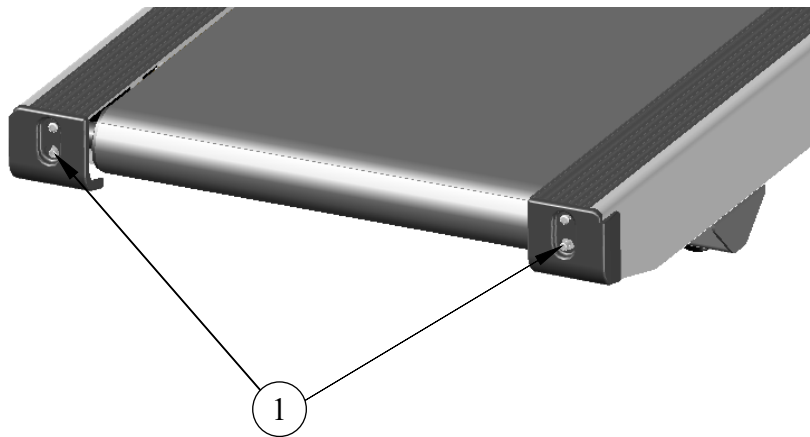

| Item | Description |
|------|---------------|
| 1 | Tension Bolts |

NOTE: Operating the treadmill at a high-speed application may cause hesitation or slippage of the running belt with each foot plant. This could be a sign of the backing of the running belt breaking down causing a premature failure.

Drive Belt Tension Adjustment

This procedure requires the following tool:

- 1/8" Allen Wrench
- 3/4" Socket or Box Wrench
- 3/4" Wrench
- Tape measure

NOTE: Because this adjustment is not covered under your warranty, it is important that you review these instructions thoroughly before proceeding.

NOTE: The drive belt may stretch and loosen with regular use. This looseness may result in a flapping noise under the hood.

1. Remove the (5) #10-32 screws located on the bottom hood with 1/8" Allen wrench.
2. With the 3/4" socket and wrench loosen the TENSION ADJUSTMENT back nut.
3. Press down on drive belt between motor and front roller with approximately 5 lbs of force to achieve 1/4" to 3/8".
4. If adjustment is need using a 3/4" wrench turn the TENSION BOLT clockwise to tighten. To loosen, turn the wrench counterclockwise.
5. Make small adjustment until the drive belt deflects approximately 1/4" to 3/8"; tighten the TENSION ADJUSTMENT back nut.

NOTE: Failure to lock the TENSION ADJUSTMENT back nut will allow the drive belt tension to become loose.

6. When the treadmill is properly adjusted, reinstall the hood with (5) #8-32 screws.

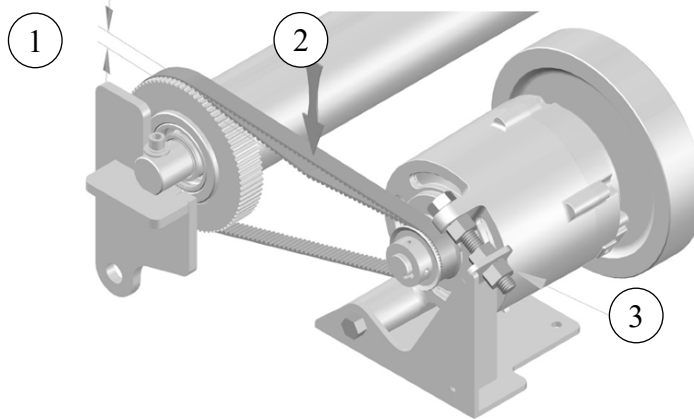

| Item | Description |
|------|------------------------------|
| 1 | 1/4 to 3/8 Deflection |
| 2 | 5 LBS |
| 3 | Tension adjustment back nut. |

NOTE: When drive belt is over tensioned, the belt tension will cause motor noise. This could result in premature motor life.

Exterior Care

The powder-coat finish on your treadmill is an extremely durable finish and requires minimal care. Do not allow perspiration to build up on your treadmill. Wipe the unit daily. (Refer to Appendix B Reprocessing Instructions)

- Use a moist cloth to wipe the surface clean; do not allow liquids to enter the system. All cleaning agents and disinfectants used in hospitals and containing up to 70% alcohol are suitable. If liquids have entered the system, notify service to have the system inspected for damage before it is used again.
- DO NOT use disinfection with a phenol base or peroxide compound to disinfect the external surface.

Elevation Screw Lubrication

The Elevation Screw must be cleaned and lubricated every 6 months to maintain proper operation of the treadmill. Failure to perform this maintenance function will result in premature wear and ultimate failure of the lift mechanism.

This procedure requires the following tools:

- TRACKMASTER[®] grease (Part # 317-160-165)
 - Clean, lint-free cloth
 - Small paint brush
1. Raise the treadmill to its maximum elevation.
 2. Turn the main power switch to the OFF position and unplug the treadmill from its outlet.
 3. Using a lint-free cloth, remove the old lubricant and accumulated dust from the elevation screw.
 4. Use a small brush to reapply a thin coat of grease to the threads of the elevation screw. Do not use too much grease—the excess could squeeze onto the floor and create a slip-and-fall hazard.
 5. Plug treadmill power cord back into the power source outlet. Cycle the main power switch to the ON position and allow the treadmill to return to the parked position.
 6. Return the unit to service.

Running Deck Maintenance

The TRACKMASTER[®] running deck is maintenance-free and offers two running deck surfaces to double the life of ordinary treadmills.

NOTE: Do not use silicone sprays to wax your treadmill deck. Using silicone sprays will void the warranty. Such sprays can bring about surface changes that may result in hesitation or excessive belt slip.

Prolonged use in high-speed running may cause hesitation or slippage on each foot plant. Inspect the running deck for factory lubrication on running surface.

If running deck surface becomes grooved due to wear, it can be renewed by flipping the deck to the opposite side.

Troubleshooting

Your in-house biomedical technician or technically qualified personnel can perform basic troubleshooting. Advanced troubleshooting may be found in the TMX428 TMX58 Service Manual shipped with your system or contact Full Vision for support.

Power Switch Will Not Illuminate

This procedure requires the use of a meter that is capable of reading at least 250 VAC and measure ohms.

1. Turn treadmill main power switch to OFF. Unplug the treadmill power cable from the wall receptacle.
2. Measure the voltage at the wall outlet for correct voltage level.
If voltage is not correct, reset circuit breaker.
If voltage is correct, proceed to next step.
3. Plug the treadmill power cable into the wall receptacle. Turn treadmill main power switch ON.
4. Observe solid RED led D7 this indicated power to the smart power supply board. The LED indicator is located next to the large transformer in the upper right hand corner when looking at the board.
5. If the Control Console does not light up verify the J12 connector on the lower smart power supply board, and the J8 connector on the upper LCD circuit board located in the Control Console. This is the main communication cable and is critical to have the connector properly seated on the connector.
6. Verify the J4 & J5 jumper is connected; it is located to the right side of the large transformer.
7. If connections at the power switch breaker are good, turn main power switch to OFF, and unplug the treadmill from the wall receptacle. Check the continuity of each conductor of the power cord. If the power cord is good, check the function of the main power switch in the ON and OFF positions. Check power cord is plugged into power switch.

NOTE: Patient or assistant may introduce an ESD discharge to the treadmill. The LCD screen may not display the speed and elevation; treadmill can be stopped by the emergency stop or safety tether.

Facility Circuit Breaker Trips When Powering Up

If the main circuit breaker trips when the treadmill is first turned on, the main circuit that the treadmill is on may be overloaded. This will not happen if the treadmill is on a proper, dedicated line. Refer this problem to your local electrician and check that the service panel circuit breaker is a high magnetic breaker.

Treadmill Will Not Start

1. Make sure the Emergency Stop Button is released.
2. Make sure the Patient Safety Tether clip or magnet is connected to switch.

3. The Control console has a blue screen with establishing communication in yellow remains on the screen. Verify the J12 connector on the lower smart power supply board, and the J8 connector on the upper LCD circuit board located in the Control Console. This is the main communication cable and is critical to have the connector properly seated on the connector.

Running Belt Slips When In Use

Over a period of time, the treadmill running belt will stretch and allow slippage when used by a heavy person. (See **Running Belt Tension Adjustment**)

Running Belt Is Off-Center

Occasionally the treadmill running belt will become off-center. (See **Running Belt Tracking Adjustment**)

Internal Circuit Breaker Location and Resetting

1. All circuit breakers are located at the front of the treadmill and below the hood. (See Motor Pan Assembly Appendix B.)
 - 2 ea. Power Supply / Relay Board (1/4 amp)
 - 2 ea. Elevation Motor (3 amp)
2. To reset a breaker, push the button.

NOTE: Contact your distributor for information on possible causes of tripped circuit breakers.

Reprocessing Instructions

The following reprocessing instructions apply to all treadmills. The treadmill is neither sterile nor can it be sterilized.

| | | |
|-------------------------------|--|---|
| Manufacturer: Full Vision Inc | | Symbol:  |
| Device(s): Treadmills | | |
| WARNINGS | <p>Before cleaning the device, turn the main power switch to OFF and disconnect the treadmill from its power outlet.</p> <p>Never use wet cleaning materials near a power source: you could suffer an electrical shock.</p> <p>Do not improperly clean the device</p> <ul style="list-style-type: none"> • During cleaning, do not allow fluid to enter the motor pan assembly area. • Always wear appropriate PPE when cleaning. • Do not use abrasive brushes or abrasive cleaners. This could damage the paint and plastic surfaces. • Do not use sharp tools (e.g. knife, metal scraper) or aggressive cleaning solvents for cleaning • Alcohols are flammable and should only be used in well ventilated spaces • DO NOT use disinfection with a phenol base or peroxide compound to disinfect the external surface | |
| Limitations on Processing | Not Applicable | |

| | |
|---------------------------------------|---|
| INSTRUCTIONS | |
| Initial Treatment at the Point of Use | Use a soft, clean, lint-free cloth / paper towel dampened (not wet) with tap water and mild detergent to wipe all treadmill surfaces to remove excess soil, moisture, and perspiration. |
| Preparation Before Cleaning | All cleaning solutions should be prepared at the dilution and temperature recommended by the manufacturer. |
| Cleaning: Automated | Not applicable |

| | |
|-----------------------------|--|
| <p>Cleaning: Manual</p> | <p>Step 1 – Turn the main power switch to OFF and disconnect the treadmill from its power outlet.</p> <p>Step 2 – Use 20 mL (0.68 oz) of an alkaline cleaner or similar mild, non-abrasive detergent (ex. Spray 409) on a soft, clean, lint-free 25 x 25 cm (9.8 x 9.8 in) size cloth / paper towel and manually clean item 1, 2, & 6 (if applicable). Reference Image 1 for corresponding items. Note: Do not spray cleaning chemical directly on the device</p> <p>Step 3 – Use an appropriately sized soft-bristled brush (e.g. standard toothbrush) dampened with 5 mL (0.17 oz) of mild soapy tap water (or similar mild, non-abrasive detergent) to clean item 3 and hard to reach spots. Reference Image 1 for corresponding items.</p> <p>Step 4 – Wipe all surfaces 1-6 (reference Image 1) with a soft, clean, lint-free 25 x 25 cm (9.8 x 9.8 in) size cloth / paper towel dampened with 20 mL (0.68 oz) (not wet) of lukewarm tap water 27°C to 44°C (80°F to 111°F) for a minimum of 30 seconds.</p> <p>Step 5 – Dispose of all cleaning materials according to your institutions established procedure.</p> |
| <p>Disinfection</p> | <p>If necessary, to disinfect the treadmill, follow these steps.</p> <p>Step 1 – Turn the main power switch to OFF and disconnect the treadmill from its power outlet.</p> <p>Step 2 – Prepare 20 mL (0.68 oz) of 70% or greater isopropyl alcohol disinfectant solution according to the manufacturer’s directions.</p> <p>Step 3 – Use a soft, clean, lint-free 25 x 25 cm (9.8 x 9.8 in) size cloth / paper towel or gauze that is saturated with 20 mL (0.68 oz) of the disinfection solution and manually disinfect all contaminated surfaces of the device for a minimum of 15 minutes.</p> <p>Step 4 – Use an appropriately sized soft-bristled brush (e.g. standard toothbrush) dampened with 5 mL (0.17 oz) of the disinfectant solution to clean item 3 and hard to reach spots. (reference Image 1 for corresponding items) Surface must remain wet for a minimum of 15 minutes.</p> <p>Step 5 – Wipe all contaminated surfaces 1-6 (reference Image 1) with a soft, clean, lint-free 25 x 25 cm (9.8 x 9.8 in) size cloth / paper towel or gauze dampened with 20 mL (0.68 oz) of purified water 27°C to 44°C (80°F to 111°F) for a minimum of 30 seconds.</p> <p>Step 6 – Dispose of all cleaning materials according to your institutions established procedure.</p> |

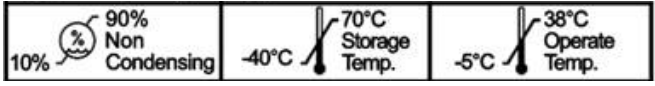
| | |
|-------------------------------------|--|
| Drying | Dry the device with a soft, clean, lint-free cloth/paper towel 25 x 25 cm (9.8 x 9.8 in). |
| Maintenance, Inspection and Testing | Visually examine each device for cleanliness. If visible soil remains, repeat cleaning procedure until the device is thoroughly clean. |
| Packaging | Not applicable |
| Sterilization | Not applicable |
| Storage |  |
| Additional Information | No additional requirements |
| Manufacturer Contact | Full Vision Inc. Email: tmservice@full-vision.com |



| Item | Description |
|------|-----------------------|
| 1 | Emergency Stop Button |

| | |
|----------|--------------------------------------|
| 2 | Patient Grab Handrails |
| 3 | Pull Tether Switch / Magnetic Tether |
| 4 | Hood |
| 5 | Running Belt |
| 6 | Controller (if applicable) |

The instructions provided have been validated by the manufacturer of the medical device as being capable of preparing a medical device for reuse. It remains the responsibility of the processor to ensure that the processing, as actually performed using equipment, materials and personnel in the processing facility, achieves the desired result. This requires verification and/or validation and routine monitoring of the process.

3017 Full Vision Drive
Newton, KS. 67114
www.full-vision.com
www.trackmastertreadmills.com

Assembled in
Newton, KS. U.S.A.