



# MEDICAL TREADMILL

---



## SERVICE MANUAL

TMX428 TMX428CP	
--------------------	--



TMX58
-------



## Contact Information

The model TMX428 TRACKMASTER® treadmill is designed to be interfaced with a variety of ECG and VO<sub>2</sub> systems. If you have a question or need assistance, please contact your system integrator first.

### Manufactured by:

  
 3017 Full Vision Drive  
 Newton, KS 67114 USA  
[www.full-vision.com](http://www.full-vision.com)  
[www.trackmastertreadmills.com](http://www.trackmastertreadmills.com)  
 Phone: (316)-283-3344  
 Fax: (316)-283-9522  
 Email: [sales2@full-vision.com](mailto:sales2@full-vision.com)

EC	REP
----	-----

European Union Authorized  
 Representative  
 Contact Details:  
**(Regulatory affairs only)**  
 Emergo Europe  
 Westervoortsedijk 60  
 6827 AT Arnhem  
 The Netherlands  
[EmergoVigilance@ul.com](mailto:EmergoVigilance@ul.com)

CH	REP
----	-----

Swiss Authorized Representative  
 Contact Details:  
**(Regulatory affairs only)**  
 MedEnvoy Switzerland  
 Gotthardstrasse 28  
 6302 Zug  
 Switzerland  
[Vigilance@medenvoyglobal.com](mailto:Vigilance@medenvoyglobal.com)

## WARNING

### MODIFICATION IS PROHIBITED

The TRACKMASTER® treadmill is manufactured to exacting standards both in physical form and in component selection. The components used in our products have been selected with performance and medical safety in mind. The treadmill has been engineered and certified to conform to the list of medical and safety regulatory standards which appear on the next page. Modification or part substitution of any kind is strictly forbidden. Any deviation in component replacement, physical or electrical modification will result in loss of medical safety certification and warranty of this product. Modifications to this equipment may put the patient at risk of electrical shock or hardware malfunction.

Contact TRACKMASTER® Service department for all your repair part needs.

## Publication Information

The information in this manual applies only to the TMX428 Treadmill, and TMX428CP Treadmill. It does not apply to earlier versions. Due to continuing product innovation and state of the art design, specifications in this manual are subject to change without notice.

TRACKMASTER® is a registered trademark. All other marks are the properties of their respective owners.

This product complies with the regulatory requirements concerning medical devices from the following bodies:



Date of first CE mark - August 2013

### Revision History

The document part number and revision history appear at the bottom of each page. The revision identifies the document's update level. The revision history of this document is summarized in the following table.

Revision	Publication Date	Description
1	August 2013	First Release
2	August 2016	Update Authorized Representative Address
3	November 2018	Added 4 <sup>th</sup> Edition EMC Tables Chapter 1
4	04 May 2021	Updated to EU MDR 2017/745 label requirements, added Reprocessing Instructions in Appendix B, updated the intended use statement.
5	24 March 2022	Implementation of New Motor and Drive Combination, 3 Wire Hall Effect Speed Sensor and Harness, Patient Safety Tether, Information Label Symbols Updated, EMC Information.
6	31 July 2023	Updated formatting, updated the EC REP address, added mounting and dismounting method steps, added additional warning to Safety Hazards to review Responsibility of the Customer, added additional warnings in other sections in regards to the Emergency Stop Button and Patient Safety Tether functionality and behavior, removed duplicate warnings and duplicate paragraphs, added images and text for the Patient Safety Tether, removed contradicting information, updated headings and descriptions, added reference to service manual and part number, clarified speed metrics. Updated 16 hour to minimum of 4 hours functional test. Updated replaced part numbers.

---

<b>Revision</b>	<b>Publication Date</b>	<b>Description</b>
7	May 2025	Updated NOT Life-supporting equipment Table 3 for IEC 60601-1-2:2014+A12020 4.1 Ed. Updated treadmill space requirements. Updated symbols in Chapter 1. Added additional statements for warnings, product overview, and Emergency Stop Switch. Added alternate certification for control panel models. Added alternate Drive and new service parts.



**Table of Contents**

Contact Information ..... i  
Publication Information ..... ii

**Introduction 11**

Intended User ..... 11  
Intended Use ..... 11  
Regulatory and Safety Information..... 12  
Reporting of serious incident..... 12  
Safety Conventions ..... 13  
Safety Hazards ..... 13  
Classification of Medical Device..... 15  
Regulatory and Safety Conformance ..... 15  
Table 1: Guidance and Manufacturer’s Declaration – Emissions ..... 16  
Table 2: Guidance and Manufacturer’s Declaration – Immunity All ME Equipment and ME Systems ..... 16  
Table 4: Guidance and Manufacturer’s Declaration – Immunity ME Equipment and ME Systems that is NOT Life-supporting ..... 17  
Table 6: Recommended Separation Distances between portable and mobile RF Communications equipment and the TMX428 Series ME Equipment and ME Systems that is NOT Life-supporting..... 18  
Responsibility of the Manufacturer ..... 19  
Responsibility of the Customer..... 19  
Product and Package Information..... 20  
Symbols..... 20  
Label Locations..... 23  
Serial Decal Information..... 26  
Service Information ..... 28  
Manual Information ..... 28  
Related Documents ..... 28  
Training..... 29

**Specifications 30**

Directional Orientation ..... 30  
Safety Systems ..... 31  
Treadmill..... 31

Drive System.....	31
Speed Range.....	31
Incline Range .....	31
Running Surface.....	31
Communication Ports.....	31
Floor Surface Footprint.....	31
Location .....	<b>Error! Bookmark not defined.</b>
Operating and Storage Condition Recommendations.....	32
<b>Power Requirements.....</b>	<b>33</b>
<b>Hi-Pot Test Instructions .....</b>	<b>35</b>
<b>Uncrating, Setup and Assembly.....</b>	<b>36</b>
Safe Handling Guidelines .....	36
Uncrating Instructions.....	37
Initial Setup Instructiton.....	38
TMX428CP & TMX58 Control Assembly .....	40
Location .....	41
Final Setup - Running Belt Tracking Adjustment .....	41
Final Setup - Running Belt Tension Adjustment.....	42
Final Setup - Drive Belt Tension Adjustment.....	42
<b>Operating Instructions .....</b>	<b>45</b>
Electrical Safety Tests.....	45
Operating Controls.....	45
Controlling the Treadmill .....	45
Power Switch .....	45
Emergency Stop Switch.....	45
Emergency Stop Switch Check.....	45
Patient Safety Tether Switch.....	46
Patient Safety Tether Switch Check .....	47
Treadmill Power Up Sequence Mode.....	47
Loss of Communication with the Host System.....	47
Loss of Communication due to Timeout .....	48
Programmable Control Instructions TMX428CP .....	49
TESTING MODE DISPLAY .....	49
MANUAL MODE DISPLAY .....	49
Control Panel Display:.....	50

---

Patient Safety Tether:.....	50
WORKOUT GRAPHICS .....	52
MANUAL OPERATION: .....	52
BUILT-IN PROGRAM OPERATION.....	54
Pre-Programmed Protocol Workout Data.....	54
Pre-Programmed Fitness Workout Data.....	57
User Defined Programming .....	60
<b>Preventive Maintenance .....</b>	<b>61</b>
Reprocessing Instructions .....	61
Daily Maintenance .....	61
Weekly Maintenance .....	61
Monthly Maintenance .....	61
Semiannual Maintenance .....	62
Belt Cleaning and Inspection .....	62
Running Belt Tracking Adjustment.....	62
Running Belt Tension Adjustment.....	63
Drive Belt Tension Adjustment .....	64
Exterior Care.....	65
Elevation Screw Lubrication.....	65
Running Deck Maintenance.....	65
<b>Product Requirements.....</b>	<b>67</b>
INTRODUCTION .....	67
SCOPE .....	67
OPERATIONAL OVERVIEW .....	67
SOFTWARE REQUIREMENTS .....	68
SPEED CONTROL .....	68
ELEVATION CONTROL .....	68
COMMUNICATION HARDWARE (RS-232 Option) .....	70
COMMUNICATION HARDWARE (USB Option).....	70
COMMAND PROTOCOL .....	70
A - INPUT COMMANDS.....	70
B - INPUT COMMAND ACKNOWLEDGEMENT .....	71
C - STATUS REQUEST .....	71
D - STATUS RESPONSE .....	71
COMMUNICATION NOTES.....	72

Self-test MODE .....	73
CALIBRATION .....	73
DIP SWITCH SETTINGS .....	73
ELECTRICAL INPUTS .....	74
ELECTRICAL OUTPUTS .....	74
ELECTRICAL CONNECTIONS.....	75
PHYSICAL REQUIREMENTS AND RESTRICTIONS .....	75
UNIVERSAL POWER SUPPLY BOARD 3.1 Edition (FGLF0495-1) .....	76
UNIVERSAL POWER SUPPLY BOARD 4 <sup>th</sup> Edition (FGLF0495-3) .....	78
<b>Troubleshooting .....</b>	<b>79</b>
Incoming Power 110-240VAC Flow Chart 1A .....	79
Incoming Power Inline Filter Flow Chart 1B .....	80
Incoming Power Drive Flow Chart 1C .....	81
Smart Power Supply Incoming Power 110-240VAC Flow Chart 1D .....	82
Emergency Stop Flow Chart 1E .....	83
Patient Safety Tether Flow Chart 1F .....	84
Communication RS232 Flow Chart 1G.....	85
Communication RS232 Flow Chart 1H.....	86
Smart Power Supply Error Code Identification Flow Chart 1I .....	87
Smart Power Supply Error Code 1 Flow Chart 1J “Bad Speed Calibration” .....	88
Smart Power Supply Error Code 2 Flow Chart 1K “Elevation Error” (3 <sup>rd</sup> Edition).....	89
Smart Power Supply Error Code 2 Flow Chart 1KK “Elevation Error” (4 <sup>th</sup> Edition).....	90
Smart Power Supply Error Code 3 Flow Chart 1L “Missing Speed Signal From Motor Controller” .....	90
Smart Power Supply Error Code 4 Flow Chart 1M “Over Speed Error Based on Motor Controller Signal” .....	92
Smart Power Supply Error Code 5 Flow Chart 1N “Missing Signal from External Speed Sensor” .....	93
Smart Power Supply Error Code 6 Flow Chart 1O “Over Speed Base On External Speed Sensor” .....	94
Smart Power Supply Error Code 7 Flow Chart 1P “Excessive Speed Mismatch” .....	95
Smart Power Supply Error Code 7 Flow Chart 1P “Excessive Speed Mismatch” Continued.....	97
Smart Power Supply Error Code 8 Flow Chart 1Q “Motor Control Reports Fault” .....	98
Smart Power Supply Error Code 9 Flow Chart 1R “Start Belt Command Received During Initialization” .....	99
Smart Power Supply Error Code 10.....	100

Control Console Communication Flow Chart 1S .....	101
Drive PC2303-012-N Status LED Code List.....	102
<b>Removal and Replacement of Components.....</b>	<b>104</b>
Hood Removal Procedure TMX428 Series .....	105
Kollmorgen Drive Motor Replacement TMX428 Series.....	106
Quantum/Trutech Drive Motor Replacement TMX428 Series .....	108
Kollmorgen Drive Board Replacement TMX428 Series.....	110
Quantum/Trutech Drive Board Replacement TMX428 Series.....	111
Conversion Kit Quantum/Trutech TMX428 Series .....	113
Front Roller Replacement TMX428 Series .....	116
Rear Roller Replacement TMX428 Series .....	117
Running Belt Replacement TMX428 Series.....	118
Deck Assembly Detail View.....	119
Running Deck Replacement TMX428 Series.....	120
Deck Cushion Replacement TMX428 Series .....	121
Motor Drive Belt Replacement TMX428 Series .....	122
Elevation Actuator Replacement/Adjustment TMX428 Series .....	123
Upgrading the Speed Sensor – 2 Wire to 3 Wire.....	124
Replacing the Speed Sensor – 3 Wire to 3 Wire.....	126
Smart Power Supply Board (SPSB) Replacement TMX428 Series .....	127
Circuit Breaker Replacement.....	128
Replace or Relocate Emergency Stop Button (ESB) & Patient Safety Tether Switch (PSTS).....	129
Validate Relocate ESB and PSTS Operation.....	130
Replacing the Center Handrail.....	130
Replacing the Right or Left Handrail.....	131
Removing and Reinstalling the Handrails for Moving.....	132
Replacing the Main Power Switch.....	132
Replacing the Power Cord .....	134
Replacing the CE filter.....	134
Replacing the Relay .....	135
<b>Established Component Replacement Time.....</b>	<b>136</b>
<b>138</b>	
<b>Calibration TMX428 Series .....</b>	<b>138</b>
Belt Speed Calibration Procedure (Calibration Program) .....	138
Belt Speed Calibration Procedure (Controller Interface).....	141

Verifying Belt Speed Calibration (in the field).....	142
Elevation Calibration Procedure (Calibration Program).....	143
Elevation Calibration Procedure (Controller Interface).....	145
Elevation Chart TMX428, TMX428CP, and TMX58.....	149
TMX428, TMX428CP, and TMX58 Elevation Actuator Adjustment.....	149
TMX428CP & TMX58 PARAMETER SCREEN.....	150
TMX428CP & TMX58 STOP HISTORY.....	150
Firmware Download FGLF0495-1 (3 <sup>rd</sup> Edition Smart Power Supply).....	151
Firmware Download FGLF0495-3 (4 <sup>th</sup> Edition Smart Power Supply).....	151
Firmware Download FGLF0496 (3 <sup>rd</sup> Edition LCD Control).....	151
Firmware Download FGLF0698-00 (4 <sup>th</sup> Edition LCD Control).....	152
Dip Switch Configuration.....	152
Log File Retrieval FGLF0495-3 (4 <sup>th</sup> Edition Smart Power Supply).....	153
<b>Parts List with Part Numbers.....</b>	<b>154</b>
Motor Mount Assembly (Kollmorgen).....	154
Motor Mount Assembly 317-759-001S (TruTech).....	155
3 <sup>rd</sup> Edition Circuit Board Assembly.....	156
3 <sup>rd</sup> Edition Final Assembly Circuit Board Connection.....	156
4 <sup>th</sup> Edition Circuit Board Assembly.....	157
4 <sup>th</sup> Edition Final Assembly Circuit Board Connection.....	157
Quantum Drive Assembly 317-761-001S(Alternate 317-995-001S).....	158
For Reference – Manufacture’s Description for individual items.....	158
Elevation Assembly.....	160
Patient Safety Tether Assembly.....	161
Pull Tether Clip Assembly.....	161
Magnetic Tether Assembly.....	162
Emergency Stop Assemblies.....	163
Motor Pan Assembly (Kollmorgan).....	164
Motor Pan Assembly (Kollmorgan) continued.....	165
Motor Pan Assembly Wiring (Kollmorgan).....	166
Motor Pan Assembly Wiring (Kollmorgan) continued.....	167
Motor Pan Assembly Wiring (Kollmorgan) continued.....	168
Motor Pan Assembly (TruTech).....	169
Motor Pan Assembly (TruTech) continued.....	170
Motor Pan Assembly Wiring (TruTech).....	171

---

Motor Pan Assembly Wiring (TruTech) continued .....	172
Motor Pan Assembly Wiring (TruTech) continued .....	173
Frame Assembly .....	174
Deck Assembly .....	176
Final Assembly .....	178
TMX428CP Controller Assembly 3rd Edition .....	181
TMX428CP Controller Assembly 4th Edition .....	183
TMX58 Controller Assembly 3 <sup>rd</sup> Edition Configuration.....	185
TMX58 Controller Assembly 3 <sup>rd</sup> Edition Configuration Continued .....	186
TMX58 Controller Assembly 4 <sup>th</sup> Edition Configuration.....	187
TMX58 Controller Assembly 4 <sup>th</sup> Edition Configuration Continued .....	188
<b>Maintenance Log.....</b>	<b>195</b>
<b>Reprocessing Instructions .....</b>	<b>197</b>

# Introduction

Congratulations on the purchase of your new TRACKMASTER® treadmill. These fine machines have been in production since 1977 and represent state-of-the-art design for heavy-duty institutional use. The TRACKMASTER® treadmill has gained worldwide recognition as one of the best and most dependable treadmills on the market. As a result, TRACKMASTER® has thousands of successful installations internationally.

This document describes the TMX428 and TMX428CP treadmills also referred to as the “system”, “device”, or “product”. The document is intended to be used by clinical professionals.

This chapter provides general information required for the proper use of the system and this manual. Familiarize yourself with this information before using the system.

This manual covers the installation and operation of your new treadmill. If you have questions, contact your system integrator or TRACKMASTER® dealer. If you need further assistance, please call the TRACKMASTER® Service Support team at (316)-283-3344.

## Intended User

This manual is geared towards helping clinical professionals with the operation of the TRACKMASTER® Treadmill. Clinical professionals are expected to have working knowledge of medical procedures, practices, and terminology as required for completing these examinations.

## Intended Use

The medical treadmills are intended as stressing devices, by providing motion to patient, to be interfaced with a variety of cardiac and pulmonary stress testing systems. The treadmill is intended to be operated by the physician, therapist, or operator acting under authorization of the physician with training per IFU under the supervision of a physician and / or therapist, with sufficient knowledge of the indications and contraindications. The medical treadmills are intended to be used in a medical facility or wellness center.

Certain models have a control panel to operate the treadmill.

Caution: Treadmill does not provide any kind of medical treatment, diagnostic or assessment.

### Indications:

- Symptoms suggesting myocardial ischemia
- Acute chest pain in patients excluded for acute coronary syndrome (ACS)
- Recent ACS treated without coronary angiography or incomplete revascularization
- Known CAD with worsening symptoms
- Prior coronary revascularization (patients 5 years or longer after Coronary artery bypass grafting [CABG] or 2 years or less after percutaneous coronary intervention [PCI])
- Vascular heart disease (to assess exercise capacity and need for surgical intervention)
- Certain cardiac arrhythmias to assess chronotropic competence
- Newly diagnosed heart failure or cardiomyopathy

**Contraindications:**

- Acute myocardial infarction within 2 to 3 days
- Unstable angina not previously stabilized by medical therapy
- Uncontrolled cardiac arrhythmias causing symptoms or hemodynamic compromise
- Symptomatic severe aortic stenosis
- Uncontrolled symptomatic heart failure
- Acute pulmonary embolus or pulmonary infarction
- Severe pulmonary hypertension
- Acute myocarditis or pericarditis or endocarditis
- Acute aortic dissection
- High-grade AV blocks
- Severe hypertension (SBP greater than 200 mm Hg, DBP greater than 110 mm Hg, or both)
- Inability to exercise given extreme obesity or other physical/mental impairment

## Regulatory and Safety Information

This section provides information about the safe use and regulatory compliance of this system. Familiarize yourself with this information and read and understand all instructions before attempting to use this system. The system was designed and manufactured to the appropriate medical regulations and controls.

The purchaser is solely responsible for the training, instruction, supervision and safety of all users of the TRACKMASTER® treadmill, and to use it as intended by the manufacturer. This device is intended to be used as a motion appliance to facilitate cardiac or VO<sub>2</sub> medical evaluation.

**NOTE:** Disregarding the safety information provided in this manual is considered abnormal use of this system and could result in injury, loss of data, and void any existing product warranties.

## Reporting of serious incident

Any serious incident that has occurred in relation to the device should be reported to the manufacturer and the competent authority of the Member State in which the user and/or patient is established.

- **To report to manufacturer:**



Email: [tmservice@full-vision.com](mailto:tmservice@full-vision.com)

- Please provide the following information:
  - The model number of the device as stated on its identification plate affixed on the device
  - The serial number of the device
  - Date of incident
  - Description of incident, including any patient or user impact/injury
  - Your contact information (facility, address, contact name, title, and telephone number)

## Safety Conventions

A **Hazard** is a source of potential injury to a person, property, or the system.

This manual uses the terms NOTE, CAUTION, and WARNING to point out hazards and to designate a degree or level of seriousness. Familiarize yourself with the following definitions and their significance.

### *Definition of Safety Conventions*

Convention	Definition
<b>NOTE</b>	Indicates a potential hazard or unsafe practice, which, if not avoided, could result in loss or destruction of property or data.  For example: <b>NOTE:</b> For maximum efficiency, the TRACKMASTER® treadmill must have its own dedicated power outlet.
<b>CAUTION</b>	Indicates a potential hazard or unsafe practice, which, if not avoided, could result in moderate or minor injury.  For example: <b>CAUTION:</b> Do not use silicone sprays to wax your treadmill deck. Using silicone sprays will void the warranty. Such sprays can bring surface changes that may cause you to slip.
<b>WARNING</b>	Indicates a potential hazard or unsafe practice, which, if not avoided, could result in death or serious injury.  For example: <b>WARNING:</b> Never open the hood of the TRACKMASTER® treadmill while it is plugged into a power outlet. Line voltage can cause severe injury or death.

## Safety Hazards

### **WARNING**

Before permitting anyone to use the **TMX428** or **TMX428CP**, do the following:

- Warn each user about the risk of falling while the belt is in motion.
- Stress the need for caution.
- Wait until the treadmill belt is moving before stepping onto the belt.
- Demonstrate the proper mounting and dismounting methods.

#### **Mounting methods:**

- **Step 1:** Instruct patient to straddle the belt and hold on to the handrails during initialization of the treadmill before starting the test
- **Step 2:** Send start/run command to the treadmill with patient still straddling the belt, wait a few seconds to ensure there is no uncommanded motion
- **Step 3:** Instruct patient to carefully step on the belt while holding on to the handrails, begin walking and continue with the test

#### **Dismounting methods:**

- **Step 1:** Slow the running belt to its minimum speed, then stop the belt
- **Step 2:** Instruct patient to carefully step off the belt while holding on to the handrails

- Show each user how to use the device as described in this manual.
- Risk of personal injury – Keep children under the age of 13 away from device.
- Ask each user to perform a supervised "test usage" at minimum belt speed to review and practice usage techniques.
- Serious injury could result from loss of balance or falls. To reduce the possibility of serious injury, carefully observe the following precautions.
- Observe all the precautions listed under "Responsibility of the Customer" on pages 14 & 15 to reduce the possibility of serious injury as a result of falls or loss of balance.

---

**WARNING**

**Serious injury or death could result from electrical shock. To reduce the possibility of electrical shock, carefully observe the following precautions.**

- To disconnect the treadmill, set the power switch to the OFF position, and remove the plug from the outlet. When the power is off, the green light on the power switch is dark.
- Never operate the device with a damaged power cord or plug.
- Power cord should be routed through frame mounted clamp and kept clear of the elevation mechanism.
- Keep the power cord out of traffic areas and away from heated surfaces.
- Never use extension cords.
- Never operate the device when it is wet.
- Never operate the device if it is not operating properly.
- Always unplug the machine before service or maintenance is performed.
- Treadmill should be serviced by authorized technicians only.
- Operator should report any electrical shock when touching the treadmill and discontinue use immediately.
- Never use the treadmill outdoors.
- Immediately discontinue use and unplug the treadmill if you smell the distinctive odor of hot electrical components.

---

**WARNING**

**Serious injury or death could result from electrical shock occurring during defibrillation. Never allow patient or operators near treadmill during defibrillation.**

---

**Portable RF communications equipment (including peripherals such as antenna cables and external antennas) should be used no closer than 30 cm (12 inches) to any part of the treadmill, including cables specified by the manufacturer. Otherwise, degradation of the performance of this equipment could result.**

---

---

**WARNING**

**Consult your physician prior to using the device to determine your physical readiness and capabilities. Stop exercising immediately and seek medical attention if you experience chest pain, dizziness or shortness of breath or if you experience symptoms of overexertion.**

---

---

**WARNING**

**Serious injury or death could result from operating the treadmill in the presence of explosive or flammable vapors and antiseptics.**

---

---

**WARNING**

**The potential for foot crush injury at frontal end of treadmill at lift mechanism (landing gear) when treadmill is descending. Keep feet and hands away from this area at all times.**

**Potential foot crush injury at rearward side rail, rear of side rail and rear roller exists when treadmill approaches full elevation. Keep feet and hands away from this area at all times.**

**In order to avoid the risk of electrical shock, this equipment must be connected to the supply grid with a protective earth.**

## Classification of Medical Device

This device is classified as follows, according to IEC 60601-1:

**NOTE: Class A 60601 Emissions 120V 60 Hz (covers only medical/commercial installations).  
Class B 60601 Emissions 220V 50/60 Hz (covers all market installations).**

### Medical Device Classification

Category	Classification
Type of protection against electrical shock	Class I motor operated physical medicine machine.
Degree of protection against electrical shocks	Type B external application applied part.
Degree of protection against harmful ingress or water	Ordinary equipment (enclosed equipment without protection against ingress of water).
Degree of safety of application in the presence of a flammable anesthetic mixture with air or with oxygen or with nitrous oxide	Equipment is not suitable for use in the presence of a flammable anesthetic mixture with air or with oxygen or with nitrous oxide.
Method(s) of sterilization or disinfection recommended by the manufacturer	Not applicable
Mode of operation	Continuous operation.

## Regulatory and Safety Conformance

TMX428 and TMX428CP meet the following safety and regulatory standards for FDA Class 1 motor operated physical medicine machines. They have been tested by Intertek Testing Services N.A Inc., and are listed by Engineering Testing Laboratories (ETL). Control Panel Models are tested by TÜV SÜD America Incorporated. However, the ultimate conformance to IEC 60601-1 is the responsibility of the system integrator when combined with other equipment. Additionally, all motorized equipment is potentially dangerous if used incorrectly. Before using the TMX428 and TMX428CP, follow all precautions listed in this chapter and read the entire Owner's Manual thoroughly. Use the TMX428 and TMX428CP only as described.

**NOTE: This equipment has been tested and found to comply with the limits for a Class B digital device, pursuant to Part 15 of the FCC Rules. These limits are designed to**

**provide reasonable protection against harmful interference when the equipment is operated in a Commercial Environmental. This equipment generates, uses, and can radiate radio frequency energy and, if not installed and used in accordance with the instruction manual, may cause harmful interference to radio communications. Operation of this equipment in a residential area is likely to cause harmful interference in which case the user will be required to correct the interference at owner's expense.**

## Table 1: Guidance and Manufacturer's Declaration – Emissions

The TMX428 Series is intended for use in the electromagnetic environment specified below. The customer or user of the TMX428 Series should ensure that it is used in such an environment.

Emissions Test	Compliance	Electromagnetic Environment – Guidance
RF Emissions CISPR 11	Group 1	The TMX428 Series uses RF energy only for its internal function. Therefore, its RF emissions are very low and are not likely to cause any interference in nearby electronic equipment.
RF Emissions CISPR 11	Class B	The TMX428 Series is suitable for use in all establishments, including domestic, and those directly connected to the public low-voltage power supply network that supplies buildings used for domestic purposes.
Harmonics IEC 61000-3-2	Class A	
Flicker IEC 61000-3-3	Complies	

## Table 2: Guidance and Manufacturer's Declaration – Immunity All ME Equipment and ME Systems

The TMX428 Series is intended for use in the electromagnetic environment specified below. The customer or user of the TMX428 Series should ensure that it is used in such an environment.

Immunity Test	IEC 60601 Test Level	Compliance Level	Electromagnetic Environment – Guidance
ESD IEC 61000-4-2	±6kV Contact ±8kV Air	±6kV Contact ±8kV Air	Floors should be wood, concrete or ceramic tile. If floors are synthetic, the r/h should be at least 30%
EFT IEC 61000-4-4	±2kV Mains ±1kV I/Os	±2kV Mains ±1kV I/Os	Mains power quality should be that of a typical commercial or hospital environment.
Surge IEC 61000-4-5	±1kV Differential ±2kV Common	±1kV Differential ±2kV Common	Mains power quality should be that of a typical commercial or hospital environment.
Voltage Dips/Dropout IEC 61000-4-11	>95% Dip for 0.5 Cycle  60% Dip for 5 Cycles  30% Dip for 25 Cycles	>95% Dip for 0.5 Cycle  60% Dip for 5 Cycles  30% Dip for 25 Cycles	Mains power quality should be that of a typical commercial or hospital environment. If the user of the TMX428 Series requires continued operation during power mains interruptions, it is recommended that the TMX428 Series be powered from an uninterruptible power supply or

	>95% Dip for 5 Seconds	>95% Dip for 5 Seconds	battery.
Power Frequency 50/60Hz Magnetic Field IEC 61000-4-8	3A/m	3A/m	Power frequency magnetic fields should be that of a typical commercial or hospital environment.

**Table 3: Guidance and Manufacturer's Declaration – Immunity ME Equipment and ME Systems that is NOT Life-supporting**

The TMX428 Series is intended for use in the electromagnetic environment specified below. The customer or user of the TMX428 Series should ensure that it is used in such an environment.

Immunity Test	IEC 60601 Test Level	Compliance Level	Electromagnetic Environment – Guidance
Conducted RF IEC 61000-4-6  Radiated RF IEC 61000-4-3	3 Vrms 150 kHz to 80 MHz  3 V/m 80 MHz to 2.5 GHz	(V1)=3Vrms (3V, 6V at ISM + Amateur Frequencies)  (E1)=3V/m (3 V/m at 80 - 2,700MHz, AM Modulation 9-28V/m, 385 - 6,000MHz, FM or Digital Modulation)	Portable and mobile communications equipment should be separated from the TMX428 Series by no less than the distances calculated/listed below:  $D=(3.5/V1)(\text{Sqrt } P)$ 150kHz to 80MHz  $D=(3.5/E1)(\text{Sqrt } P)$ 80 to 800 MHz  $D=(7/E1)(\text{Sqrt } P)$ 800 MHz to 2.5 GHz  Where P is the max power in watts and D is the recommended separation distance in meters.  Field strengths from fixed transmitters, as determined by an electromagnetic site survey, should be less than the compliance levels (V1 and E1).  Interference may occur in the vicinity of equipment containing a transmitter.
Enclosure Port Immunity to Proximity Magnetic Fields IEC 60601-1-2:2014+A1:2020 ed 4.1	134,2 kHz  13,56 MHz	Pulse Modulation 2,1 kHz, 65* A/m  Pulse Modulation 50 kHz, 7,5* A/m	The carrier shall be modulated using a 50% duty cycle square wave signal. *r.m.s before modulation is applied.

## Table 6: Recommended Separation Distances between portable and mobile RF Communications equipment and the TMX428 Series ME Equipment and ME Systems that is NOT Life-supporting

The TMX428 Series is intended for use in the electromagnetic environment in which radiated disturbances are controlled. The customer or user of the TMX428 Series can help prevent electromagnetic interference by maintaining a minimum distance between portable and mobile RF Communications Equipment and the TMX428 Series as recommended below, according to the maximum output power of the communications equipment.

Max Output Power (Watts)	Separation (m) 150kHz to 80MHz	Separation (m) 80 to 800MHz	Separation (m) 800MHz to 2.5GHz
	$D=(3.5/\sqrt{P})$ (Sqrt P)	$D=(3.5/\sqrt{P})$ (Sqrt P)	$D=(7/\sqrt{P})$ (Sqrt P)
0.01	0.11667	0.11667	0.23333
0.1	0.36894	0.36894	0.73785
1	1.1667	1.1667	2.3333
10	3.6894	3.6894	7.3785
100	11.667	11.667	23.333

## Responsibility of the Manufacturer

Full-Vision Inc. is responsible for the effects of safety, reliability, and performance of the treadmill only if the following conditions are met:

- Assembly operations, extensions, readjustments, modifications, or repairs are carried out by authorized personnel.
- The electrical installation of the relevant room complies with the requirements of the appropriate local, state, and other government regulations.
- The equipment is used in accordance with the instructions for use.

## Responsibility of the Customer

The customer is responsible for providing appropriate desks, chairs, electrical wall outlets, network connections, analog phone lines, and locating any of the system components described in this manual in compliance with all local, state, and national codes.

The customer is solely responsible for the training, instruction, supervision and safety of all users of the **TMX428** and **TMX428CP**, and to use it as intended by the manufacturer. This device is intended to be used as a motion appliance to facilitate cardiac or VO<sub>2</sub> medical evaluation.

- Read this Operator's Manual before operating the **TMX428** and **TMX428CP**.
- Assist in off-loading the patient in the event of abnormal or unexpected operation of the treadmill.
- If the treadmill is not responding properly, stop the treadmill, assist in removing the patient off the running belt, unplug the treadmill power supply, and seek factory authorized repair before attempting to restart the treadmill.
- Never allow children or pets near the machine without qualified adult supervision.
- Note the location of stop and/or emergency stop controls and their operation before starting a test or workout.
- The Patient must always wear the Patient Safety Tether lanyard while operating the **TMX428** and **TMX428CP**.

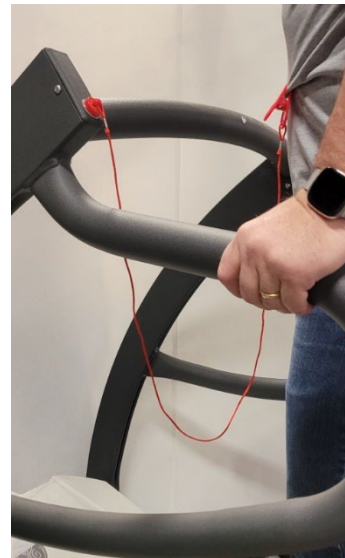

- In the event the patient falls and the Patient Safety Tether lanyard fails to disengage, use the Emergency Stop Button on the Treadmill to stop the treadmill as this disengages the motor and allows the treadmill to freewheel to a stop
- **THIS DEVICE IS NOT** intended for use by persons with reduced physical, sensory or mental capabilities, or lack of experience and knowledge unless they have been given supervision or instruction concerning use of the appliance by a person responsible for their safety.

- Verify the Patient and Operator understands how to stop the machine in the event of malfunction or emergency.
- Patient should not wear loose fitting nylon material when exercising on this treadmill to avoid generating Electrostatic Discharge.
- Never attempt to remove any article of clothing while the running belt is moving.
- All persons on and around the treadmill must wear enclosed, protective footwear. Shoelaces must be tight and not drape as to cause a trip or catch hazard. Sandals, flip flops, slippers and the like are not considered enclosed, protective footwear.
- Walk in the center of the running belt. Contact with the side rail and the moving belt could cause injury.
- Place the treadmill on a hard, level and unobstructed surface. See Chapter 5 of this manual.
- Check input power cord connection and location for hazardous pinch points before use.
- Check input communications cord connection (if equipped) for proper interface with all equipment.
- Keep all cords clear of patient to avoid trip hazards.
- Never attempt to remove the motor pan hood or do electrical repairs yourself. Repairs should only be done by a factory authorized repair provider.
- Always unplug the **TMX428** and **TMX428CP** when servicing, inspecting or cleaning the treadmill.
- Routinely inspect the treadmill for loose parts.
- Inspect handrails and ensure they will support the patient properly.
- Always start the running belt at its slowest speed before starting the patient test.
- Always slow the running belt to its minimum speed before stopping.
- Keep hands, feet, and clothing away from any moving parts.
- Verify no one is near the elevation mechanism before operating. Never put any part of the body under any part of a running treadmill.
- Never drop or insert objects into any opening.
- Never drape garments, hook-up leads, or other equipment over the side rails or drop objects on the belt while the **TMX428** and **TMX428CP** is running.
- Do not allow moisture or oils to accumulate on equipment, creating a slip hazard.

## Product and Package Information









This section describes the location of the labels used on your device and its packaging. It also describes the symbols used on the labels.







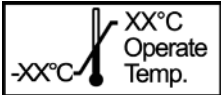
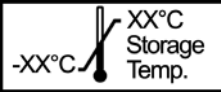

## Symbols





The following symbols may appear on the device or its packaging. Familiarity with these symbols assists in the safe use and disposal of the equipment. For equipment symbols not shown, refer to the original equipment manufacturers (OEM) manuals.

Symbols are used to convey warnings, cautions, prohibitions, mandatory actions, or information. Any hazard symbols on your device or packaging with markings in color indicates there is certain danger and is a warning. Any hazard symbols on your device or packaging that is in black and white indicates a potential hazard and is a caution.

*Symbols Glossary*

Symbol	Description/Definition
	<b>Catalog or Orderable Part Number</b> Indicates the manufacturer's catalog or part number.
	<b>Catalog or Orderable Part Number</b> Indicates the manufacturer's catalog or part number.
	<b>Serial Number</b> Indicates the manufacturer's serial number.
	<b>Manufacturer Name, Address and Manufacturing (Year-Month-Day)</b> Indicates the name and address for the manufacturer of this device.
	<b>CAUTION:</b>  CONSULT ACCOMPANYING DOCUMENTS - There may be specific warnings or precautions associated with the device that are not otherwise found on the label.  Consult the accompanying documentation for more information about safely using this device.
	<b>CAUTION:</b>  ELECTRIC SHOCK - Indicates the presence of hazardous energy circuits or electric shock hazards.  To reduce the risk of electric shock hazards, do not open this enclosure. Refer servicing to qualified personnel.
	Reading of the Owner's Manual is mandatory.
	Elevation incline / decline adjustment, TMX428CP Only
	Running belt speed adjustment, TMX428CP Only
	<b>Operate Temperature Limit</b> Indicates the maximum temperature to Operating Temperature of device.
	<b>Storage Temperature Limits</b> Indicates the upper and lower temperature limitations for the transportation and handling of this package.

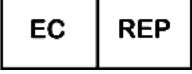
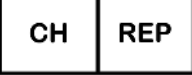
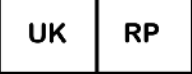
Symbol	Description/Definition
	<p><b>Humidity Limits</b></p> <p>Indicates the upper and lower Non Condensing Humidity limitations for the transportation, handling of this package and Operating of device.</p>
	<p>This equipment complies with the EU WEEE marking requirement for proper disposal of electrical and electronic waste in accordance with the European Directive 2012/19/EU. This directive calls for separation and recovery or reuse of used electrical or electronic equipment upon end of life EEE disposal.</p> <p>The TRACKMASTER® must not be disposed of as unsorted municipal waste. Electrical or electronic components must be collected separately and disposed of in accordance with your local requirements and sources. The EEE program minimizes any potential effects on the environment and user health by eliminating the potential presence of hazardous substances in the waste stream. Customers should contact their local authorities or TRACKMASTER® Distributor for guidance in complying with the directive.</p>
	<p><b>Keep Dry</b></p> <p>Indicates that you need to keep the container away from rain and other sources of moisture.</p>
	<p><b>CE Mark</b></p> <p>Indicates the device or product conforms to applicable EU (European Union) directives.</p>
	<p><b>Electrical Testing Laboratories</b></p> <p><b>Indicates the device or product has been tested by an accredited third-party testing laboratory and meets applicable safety standards for sale and distribution within North America.</b></p> <p><b>Traditional and Control Panel models are marked separately.</b></p>
	<p>Protective earth (ground).</p>
	<p>Alternating current.</p>
	<p>Device is suitable for the external application of the type “B” applied parts.</p>

Symbol	Description/Definition
	Unique Device Identification is a unique marking of the medical device
	Follow operating instructions
	Medical device
	Authorized Representative In European Union (Regulatory affairs only).
	Authorized Representative In Switzerland
	United Kingdom Responsible Person
	Importer: Indicates the entity importing the medical device into the locale.

### Label Locations

This section identifies the labels and their locations on the product and packaging.  
**TMX428 & TMX428CP**

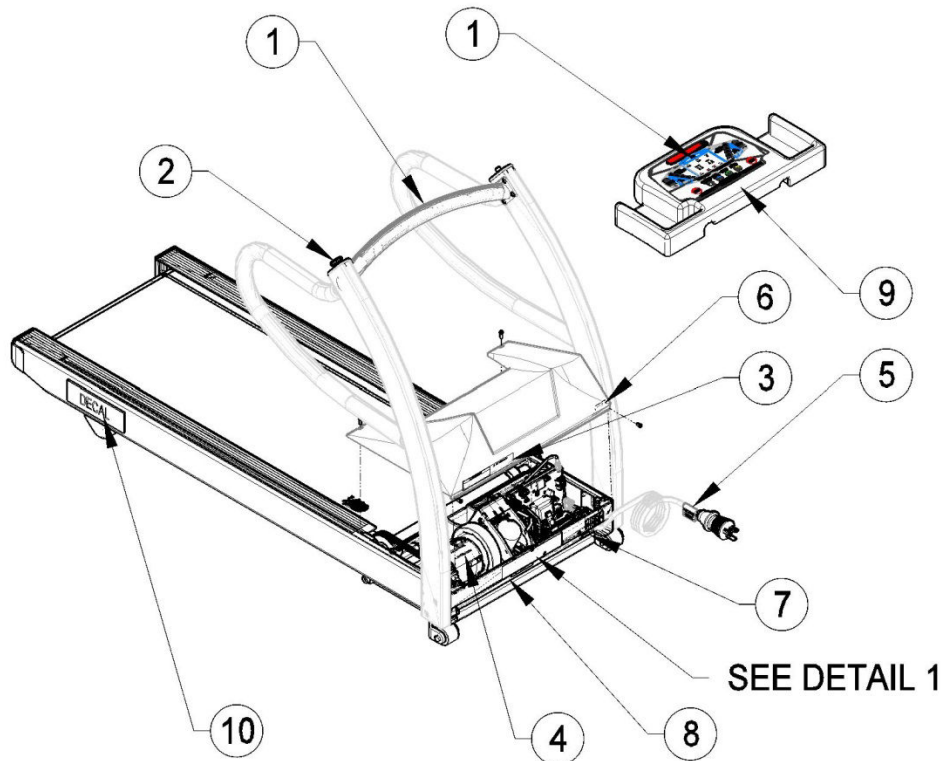

**Shipping TMX428 & TMX428CP**

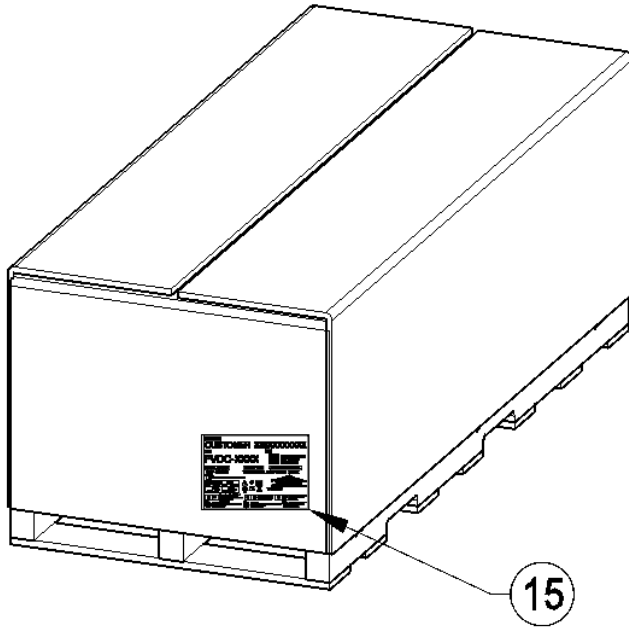



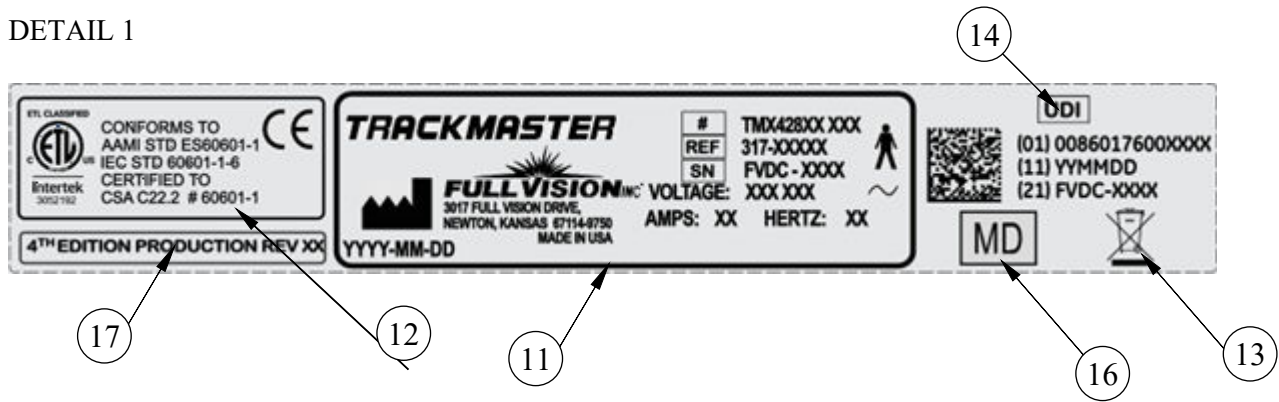



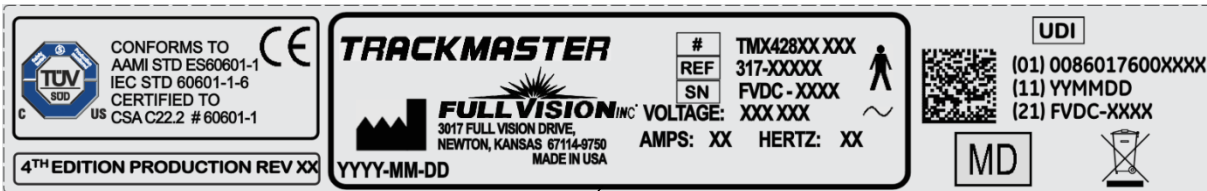

DETAIL 1



**Control Panel Alternate**

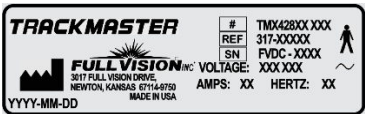
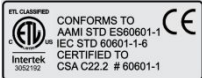

Item	Label	Location	Description
1		TMX428 on center handrail TMX428CP center console	<b>Identifies Reading of the Owner's Manual</b>
2		Stop on RH or LH end cap on handrail	<b>Identifies E-Stop</b>
3		Front of the device on the hood	<b>Identifies the Caution Electrical shock hazard</b>
4		On the motor	<b>Identifies the Caution Electrical shock hazard</b>
5		On the Power Cord	<b>Identifies DC Hi-Pot Caution</b>
6		Front of the device on the hood	<b>Identifies Master Power switch.</b>
7		Front of the device	<b>Identifies Power Off (disconnection form mains) and Power On (connection to the mains)</b>
8		Front of the device	<b>Identifies the location for the RS232 &amp; USB connection point.</b>
9		TMX428CP Front of control panel.	<b>Identifies Warning-Risk of injury- Keep children under the age of 13 away from machine.</b>
10	Customer Decal	On side channel Right & Left position above rear foot.	<b>Identifies Customer LOGO</b>
11		Front of device	<b>Identifies the Product Model</b>
12		Front of device	<b>Identifies Listing Standards</b>

			<b>Control Panel Models marked separately.</b>
13		Front of device	<b>Contains the European Union disposal requirements</b>
14		Front of the device on motor pan & on Shipping label.	<b>Identifies Unique Device Identifier</b> <ul style="list-style-type: none"> <li>• (01) GTIN Number</li> <li>• (11) Manufacture Date</li> <li>• (21) Serial Number</li> </ul>
15		On shipping container.	<b>Identifies the following information for shipping:</b> <ul style="list-style-type: none"> <li>• Customer</li> <li>• Model Number</li> <li>• Revision</li> <li>• Serial Number</li> <li>• Storage conditions</li> <li>• Regulatory Compliance</li> <li>• Country of origin</li> <li>• EC Representative information</li> </ul>
16		Front of device	<b>Identifies Medical Device</b>
17		Front of device	<b>Identifies 4<sup>TH</sup> Edition Production and current revision control.</b>
18		Front of device	<b>Identifies Economic Operator</b>
19		Front of device	<b>Identifies Importer</b>

## Serial Decal Information

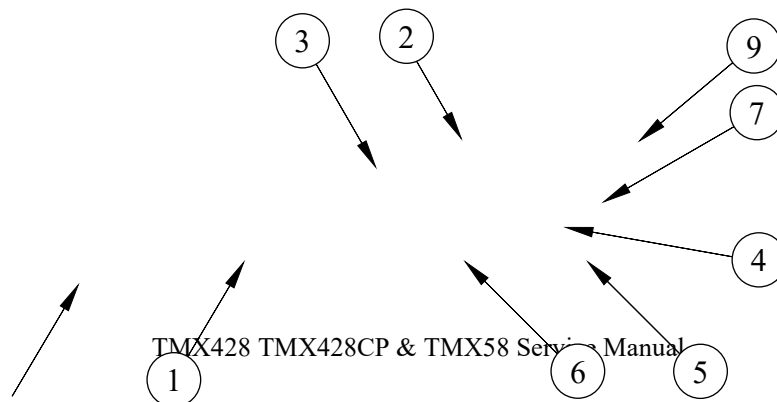



8

***Serial Decal Format***

<b>Item</b>	<b>Name</b>	<b>Description</b>
1	Manufacturer	Full Vision Inc.
2	Model Number	Identifies model of treadmill
3	Part Number	Manufacturers part number
4	Voltage	Specifies operating voltage of treadmill
5	Hertz	Specifies the electrical hertz of treadmill
6	Amps	Specifies amperage of treadmill
7	Serial Number	Manufacturers assigned serial number
8	Manufacturer Date	Manufacturers date code
9	Type B Equipment	Device is suitable for the external application of type "B" applied parts

**Service Information**

This section provides information pertaining to the maintenance and servicing of the system. Familiarize yourself with this information before requesting service from Full Vision or its authorized representatives.

**Service Requirements**

Failure on the part of the responsible individual, hospital, or institution using this equipment to implement a satisfactory maintenance schedule may cause undue equipment failure and possible safety hazards.

Regular maintenance, irrespective of usage, is essential to ensure that the components of this system are always functional when required.

**Warranty Information**

This device is considered Full Vision-supplied hardware. Only authorized service personnel should service the device. Any unauthorized attempt to repair equipment under warranty voids that warranty. It is the user's responsibility to report the need for service to Full Vision or to one of their authorized agents.

**Manual Information**

This section provides information for the correct use of this manual. Keep this manual with the equipment at all times and periodically review it.

**Manual Purpose**

This manual provides information necessary for the configuration and safe operation of this equipment in accordance with its function and intended use. It is not intended as a replacement for, but a supplement to, thorough product training. Keep it with the equipment at all times. Additional manuals may be ordered by contacting Full Vision.

Refer to the service manual for technical information related to the maintenance and repair of the equipment.

**Related Documents**

The following documents are referenced in this manual and provide additional information that may be helpful in the installation, configuration, maintenance, and use of this product.

Part Number	Title
317-160-284	TMX428 Owner's Manual

## **Training**

This manual is intended as a supplement to, not a substitute for, thorough product training. If you have not received training on the use of the system, you should request training assistance from your TRACKMASTER® dealer.

If you need further assistance, please call the TRACKMASTER® Service Support team at (316)-283-3344.

# Specifications

## Directional Orientation

References to left, right, front, and rear are based on the assumption that you are standing on the treadmill (TMX-428), facing the control console (TMX-428CP). All parts listed below are considered Patient Applied Parts except where noted.

Essential Performance: Under normal power supply conditions, the treadmill continues to perform its intended operation at the set speed and set elevation. This is unless a change is commanded by a Host Device, Control Panel, or otherwise interrupted by the user through the Emergency Stop Button or the Tether Switch

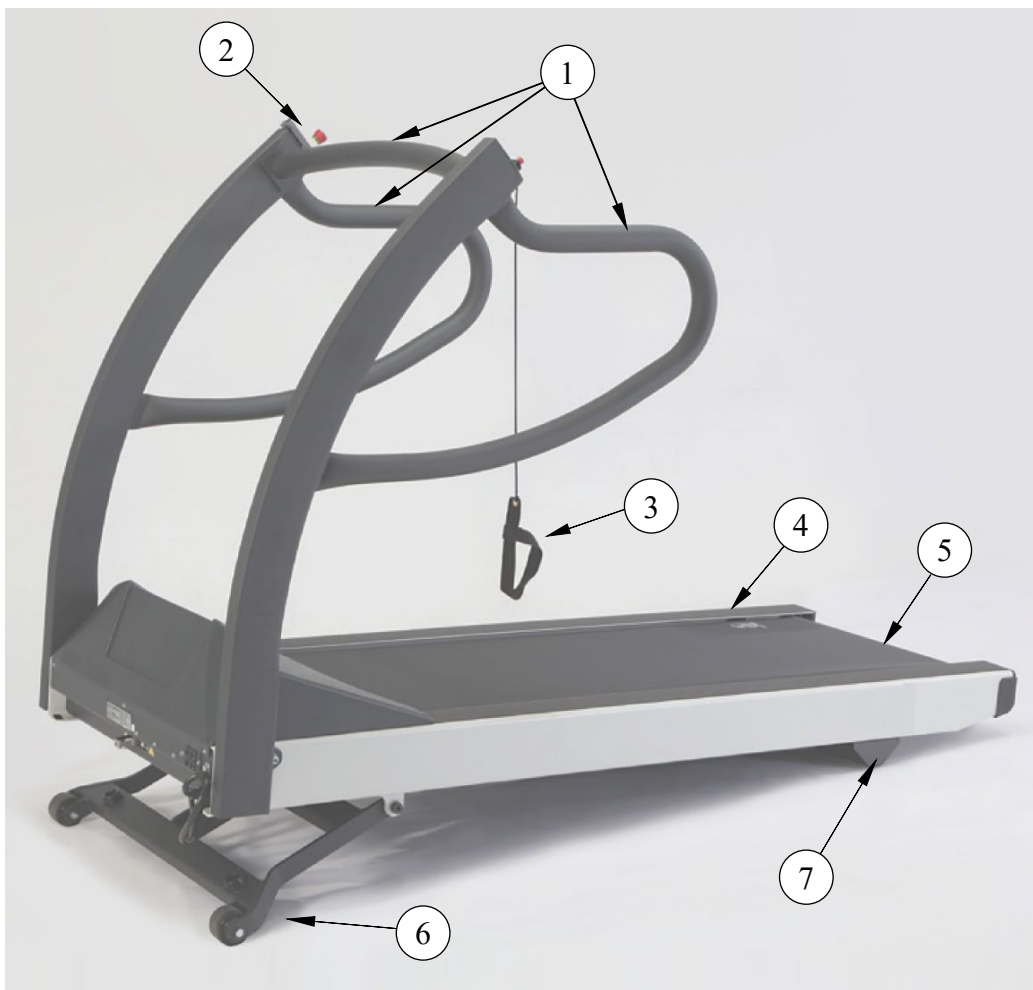

Item	Description
1	Patient Grab Rails
2	Emergency Stop Button
3	Patient Safety Tether- Wrist Strap Tether or Magnetic Tether Clip
4	Side Rail
5	Running Belt

6	Elevation Landing Gear (Non-Applied Part)
7	Rear Foot (Non-Applied Part)

## Safety Systems

- Dual comparative speed sensors
- Auto runaway shutdown
- Auto communication loss shutdown
- Manual twist lock Emergency Stop button
- Patient Safety Tether Switch
- Braking system for safe patient offloading
- Fire rated motor pan hood enclosure



TMX428CP Programmable Control

## Treadmill

- Patient weight capacity 500 lb., 227 kg
- All steel construction with baked powder-coat finish
- Treadmill net weight: 425 lb., 193 kg

## Drive System

- Heavy-duty 4-peak hp. brushless, DC servo motor
- 110-120VAC, 1-phase, 60 Hz, 20-amp power supply (standard)
- 200-240VAC, 1-phase, 50-60 Hz, 15-amp power supply (optional)
- 220 VAC, Split phase, 50-60 Hz, 15-amp power supply (optional-US Configuration)

## Speed Range

- 0.1 to 15.0 mph, 0.2 to 24.0 km/h, self-calibrating and adjustable in 0.1 mph, 0.1 km/h increments.

---

**NOTE: The 220VAC maximum speed (15.0 mph/24.0 km/h) will deteriorate at lower voltages (210VAC or below).**

---

## Incline Range

- 0 to 25%, .5% incremental movements, self-calibrating.

## Running Surface

- 22in. x 63in. 56cm x 160cm
- MasterTrack® running belt tracking system
- Cushioned running deck absorbs shock of foot falls
- Self-lubricated and reversible running deck
- Step up height (7 inches., 18cm from floor)

## Communication Ports

- RS232 Female Serial port
- USB 1.0 “B” port

## Floor Surface Footprint

- 33in. x 78.5 in., 84cm x 200cm level surface. (See

## Location

- Chapter 5.)

## Operating and Storage Condition Recommendations

- Operating Temperature Range: 4.5° to +38° C (+40° to +85° F)
- Storage Temperature Range: -40° to +70° C (-40° to +158° F)
- Operating and Storage Relative Humidity Range: 10% - 90%, non-condensing
- Altitude: -50 to 5,280 feet, or about -15 to 1609 meters.

# Power Requirements

The TMX428 and TMX428CP are designed to operate on a dedicated 110-120 VAC 20-amp power supply or optional 220/240 VAC 15-amp. Make sure that the treadmill is connected to an outlet that looks like the following illustration.

This product is equipped with a three-wire grounding-type plug. The plug will only fit into a grounding-type outlet. This safety feature must not be disabled. Contact a qualified electrician if you are unable to insert the plug into your outlet, or uncertain if the outlet meets local electrical codes. Polarized outlets such as NEMA 5-20 and CEE7/7 must be verified for proper polarity configuration before plugging in the device. Incorrect polarization of the outlet could cause failure of onboard electrical components or cause electrical shock. Proper grounding is necessary for the equipment to meet acceptable current leakage standards consistent with the standards to which it was certified.



110-120 VAC  
NEMA 5-20R  
Single Phase



220/240 VAC  
NEMA 6-15R  
Split Phase



230 VAC  
AS/NZS 3112  
Option



220/240 VAC  
CEE 7/7 EURO  
Option



250 VAC  
Type N BRAZIL  
Option

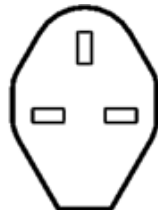

230 VAC  
BS1363  
Option

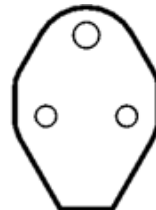

240 VAC  
BS546 3 PIN  
Option

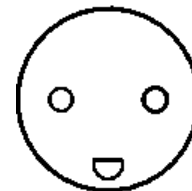

250 VAC  
Type K DANISH  
Option



240 VAC  
GB 1002  
Option

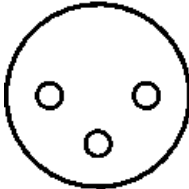

250 VAC  
Type H ISRAEL  
Option

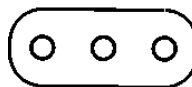

250 VAC  
Type L ITALY  
Option

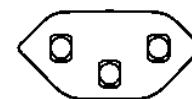

250 VAC  
Type J SWISS  
Option

**WARNING**

**TRACKMASTER® treadmills must be grounded to reduce the risk of electrical shock. If a malfunction occurs, earth grounding provides a path of least resistance for an electric current. Ungrounded connections must not be used.**

**No other equipment may be used on the electrical circuit with the device. Do not use extension cords. Using a shared or unreliable circuit can also cause the device to unexpectedly shut off, potentially resulting in injury to the patient.**

**Ensure the master power switch is in the off position before plugging in the device. A power surge could damage the sophisticated electronic system of the treadmill.**

---

**NOTE: Maximum length of power cord should not exceed 10 Feet or 3.05 Meters. Replacement Power Cords need to be ordered through the manufacturer of the operating equipment.**

---

**WARNING**

**Use of this equipment adjacent to or stacked with other equipment should be avoided because it could result in improper operation. If such use is necessary, this equipment and the other equipment should be observed to verify that they are operating normally.**

---

**WARNING**

**Only use accessories, transducers and cables provided by the manufacturer of the equipment. Using alternative non supplied accessories of the components listed above could result in increased electromagnetic emissions or decreased electromagnetic immunity of the equipment and could result in improper operation.**

---

## 4

# Hi-Pot Test Instructions

**This test must only be performed by a qualified electrician.**

Your Trackmaster® Treadmill has been Hi-Pot tested at the factory just prior to shipment and found to be within specifications. However, some facilities require Hi Pot test verification before the treadmill is put into service. The following instructions must be followed to prevent permanent damage to the Trackmaster® electronic control system. Failure to follow these instructions will void your warranty.

**NEVER USE AN AC HI-POT TESTER ON THIS TREADMILL!**

**Using an AC Hi-Pot tester will permanently damage the DC motor controller board rendering the treadmill inoperable.**

Hi-Pot test instructions for Treadmills

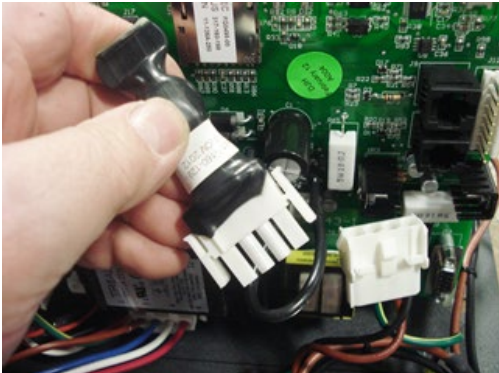
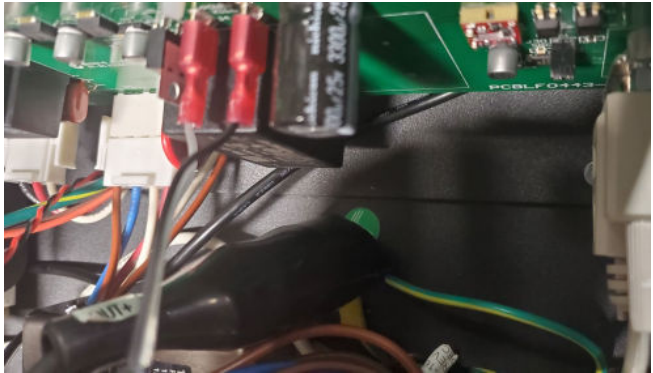
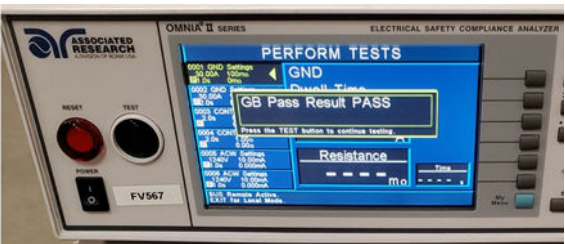
	
<p>1. Unplug the surge suppressor from the main wire harness.</p>	<p>2. Attach DC Hi-Pot tester ground clip to a known chassis ground on the treadmill.</p>
	<p>3. For 110V models: Test at 1.75 KV DC for 60 seconds. This is equivalent to 1240 VAC.</p> <p>4. For 220V models: Test at 2.10 KV DC for 60 seconds. This is equivalent to 1488 VAC.</p> <p>The tester should register a PASS for either test.</p>

# Uncrating, Setup and Assembly

TRACKMASTER® treadmills are shipped fully assembled and packaged in a knock down condition. They are designed to pass through a standard 36" door opening measuring at least 35½". It will be necessary to remove the door from the jam in most cases if the door is not capable of opening fully parallel to door opening. After you have uncrated the treadmill and secured the handrail assembly to the frame, move the treadmill to the area by rolling it on its front wheels

## Safe Handling Guidelines

- Do not attempt to move the treadmill with the handrails in the shipping position due to the possibility of cutting the internal wiring. You must either fully secure the handrails in their upright position or secure handrails in the folded position with 3/8-16 bolt. (see uncrating instructions below)
- Lift the end of the bed assembly to a comfortable height, keeping knees bent and back straight as you lift.
- Rotate the treadmill in the direction you want to go (the treadmill will pivot on its wheels) and push forward.
- When you have maneuvered the treadmill into its location, gently lower the end of the bed assembly to the floor.



### **WARNING**

**The treadmills weigh 425 lbs. This requires 2 people to safely remove it from the pallet and locate it in the facility.**

**If you are moving the treadmill over rough surface, such as pavement, use a dolly under front of the treadmill to prevent damage to the wheels and lift mechanism.**

## Uncrating Instructions

Tools recommended for uncrating

- Safety Knife

1. The treadmill is shipped in a cardboard box with a wood pallet. Cut the 3 nylon straps holding the cardboard cover to the wood pallet.
2. Remove the cardboard box by lifting straight up from one end to clear the treadmill.
3. Carefully cut the zip tie to open the protective plastic bag.
4. Pull the plastic bag down and fold over all 4 corners of the pallet.

---

**NOTE: This will prevent the plastic bag being rolled up into the elevation wheels when removing from wood pallet.**

---

5. Carefully cut the nylon strap securing the treadmill to the pallet.

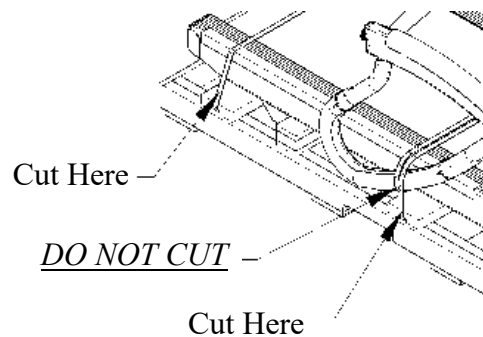

6. DO NOT REMOVE nylon strap for the handrails.

---

**CAUTION: DO NOT REMOVE treadmill from wood pallet with a forklift. The treadmill may slide off fork causing damage to handrails & side channels.**

---

**WARNING: The treadmills weigh 425 lbs. This requires 2 people to safely remove it from the pallet and locate it in the facility.**

7. Remove from the wood pallet by lifting from the rear of the treadmill and slide off one corner at a time.

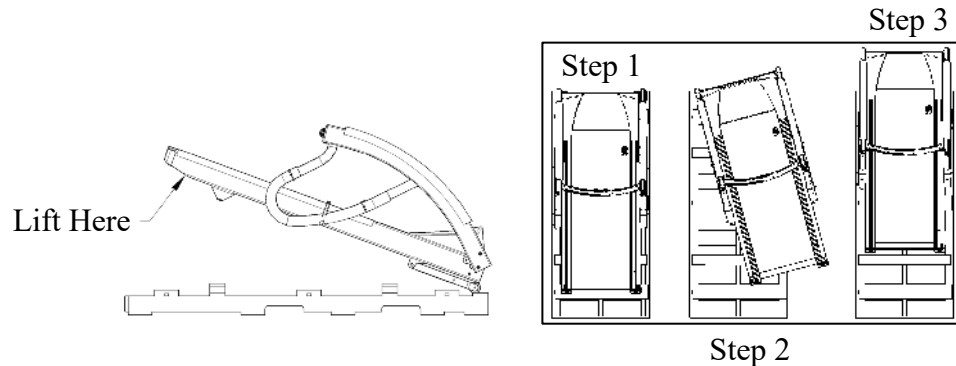

## NOTICE

- When moving leave handrails in folded position secured with nylon strap.
  - **NOTE** ▪ Required minimum clearance of 35 1/2" (902mm) to prevent handrail damage.
- At final installation set-up handrails and remove packaging materials.
  - **NOTE** ▪ Removing packaging materials with sharp objects may cause cosmetic damage to treadmill.

8. When moving or relocating the treadmill use a furniture dolly or floor dolly.
9. Position the dolly at the elevation pivot point to provide treadmill balance.

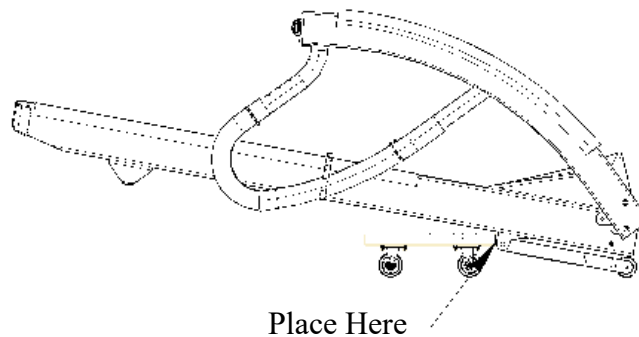

---

**NOTE:** When moving to final destination you may experience a narrow passage or doorway. The treadmill can be tipped on the side with handrails in the folded position. This will allow clearance to a minimum of 28" (711mm) to safely pass thru opening.

---

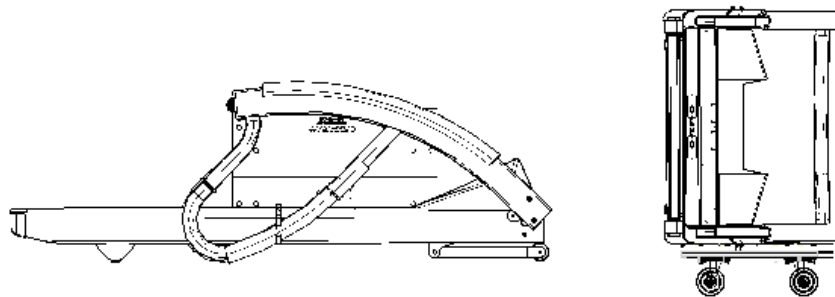

10. Carefully remove the stretch wrap, nylon strap, and protective packaging material.
11. Next step see Initial Setup Instruction.

## Initial Setup Instrucion

Tools required for assembly

- 5/16 Allen wrench (supplied)

The treadmill is shipped with the handrails loose, straddling the treadmill frame. It is advised that you secure the handrails in their proper location before removing the treadmill from the base of

the crate. This prevents the internal wires running down the handrail mount to the motor pan from being cut.

1. Swing the handrail assembly into the operating position and insert (2) 3/8-16 bolts and 3/8 lock washer each side and tighten securely.
2. Install (2) plastic caps each side for a finished look. Figure 5-1

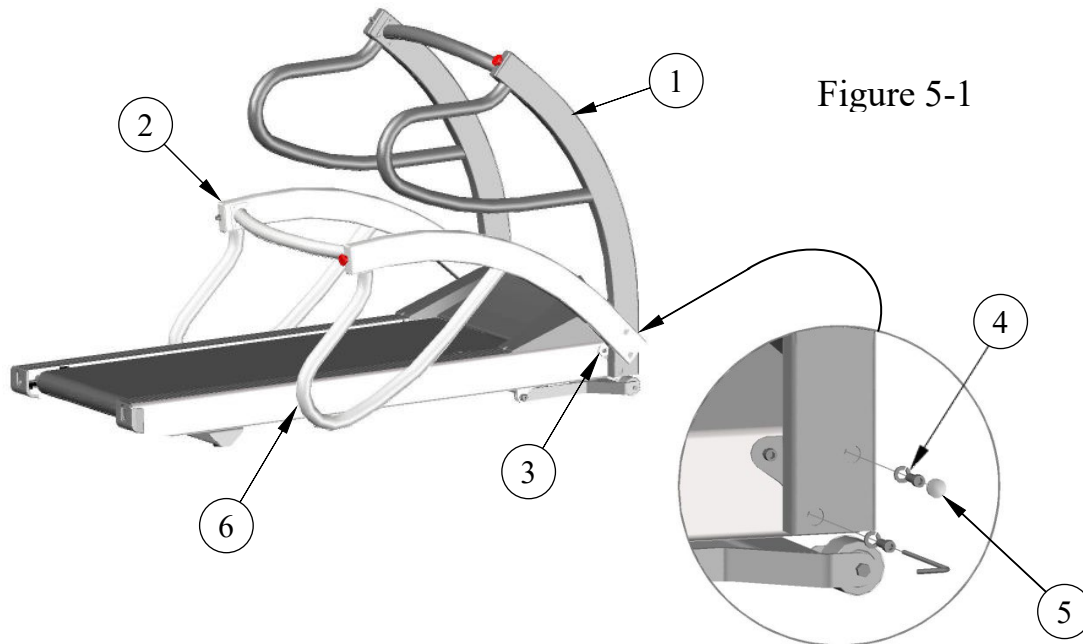
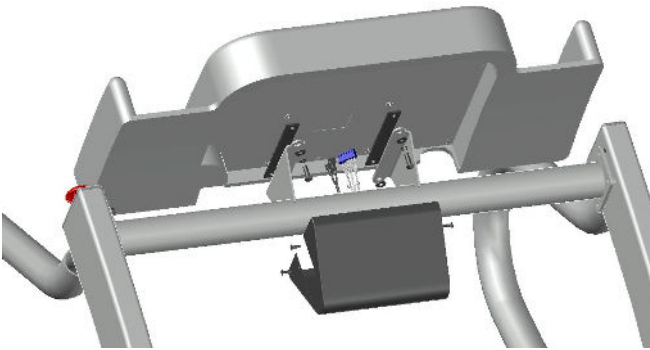

Figure 5-1

Item	Description
1	Operating Position
2	Shipping Position
3	Pivot Point
4	Insert (2) washers and bolts each side
5	Insert (2) caps each side
6	When folding handrails, apply cardboard between frame and handrail to prevent handrail damage.

## TMX428CP & TMX58 Control Assembly



**Figure 5-2**

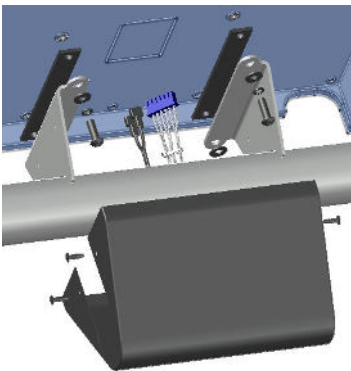

**Figure 5-3**

3. Figure 5-2 shows the mounting components included with the shipment of the treadmill. The kit contains:

- (4) ¼-20 bolts
- (1) Black cover
- (4) #10-32 Screws
- (2) Rubber isolators
- (4) Washers

4. Connect electrical 6 pin connection to J8 and quick disconnect to BC4 and BC5 to the back of the LCD Screen console from the connectors within the handrail cross brace.
5. Attach the console to the console supports with the hardware supplied in the order shown in Figure 5-3. Ensure the rubber pads are placed between the steel mounting surface and the back of the console. Tighten bolts evenly.
6. Position the black cover and align the holes in the side of the mount with those in the cover. Secure cover with (4) #10-32 screws.

## Location

Place the treadmill on a firm and level hard surface that is free of tile grout lines. The illustration below shows the minimum recommended clearances from the treadmill edges to any obstruction for dismount and safety purposes. Observe that the operator should be stationed by the E-Stop.

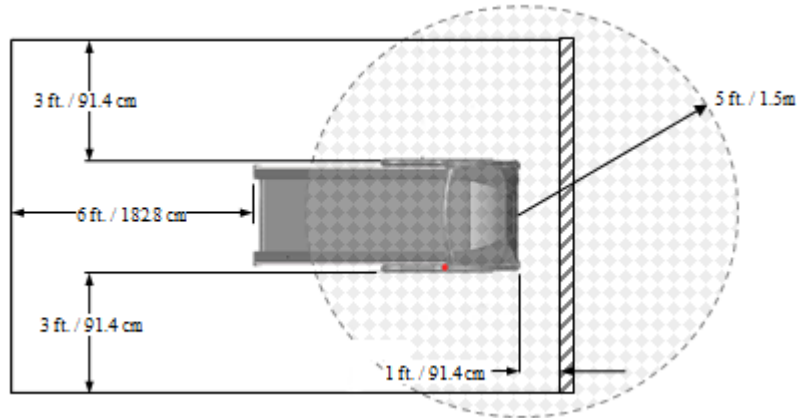

### WARNING

The TMX428 and TMX428CP conforms to FCC class B rating for electromagnetic emissions. It is recommended not to place the treadmill closer than 5ft. (1.5m) from sensitive electronic devices within the room or in an adjacent room. If an interference problem occurs, move the treadmill farther away from the sensitive device or relocate either device to another area, or consult with an EMI specialist for ways to shield the room from electromagnetic radiation.

Do not place it on thick or long-pile carpeting. Such carpeting could cause instability or static build-up, and carpet fibers could get caught in the belt and damage the unit.

Ensure that power cords do not cross traffic areas. Exposed power cords can cause a fall, resulting in injury.

Keep it away from sources of moisture, such as spas or fountains. Moisture can cause the electronic circuitry to malfunction.

## Final Setup - Running Belt Tracking Adjustment

**NOTE:** Because this adjustment is not covered under your warranty, it is important that you review these instructions thoroughly before proceeding. Uneven floors accelerate belt misalignment. This situation may require more frequent adjustments to prevent belt damage.

The MasterTrack® Belt Tracking System significantly reduces the need to adjust the belt on your treadmill. However, when you operate your treadmill for the first time, you may need to adjust the tracking of the belt to conform to your floor. You may also need to adjust the tracking if you move the machine to another location. (See **Running Belt Tracking Adjustment**)

## Final Setup - Running Belt Tension Adjustment

Your TRACKMASTER® running belt has been pre-tensioned at the factory and run for a minimum of 4 hours prior to shipment. It may, however, be necessary to adjust the belt tension when the treadmill is run in its final location. A loose belt tends to hesitate or stick with a heavy foot plant. If your belt needs tensioning, the adjustment procedure can be found in **(See Running Belt Tension Adjustment**

---

**NOTE: Improper adjustment could cause the treadmill to hesitate and cause a trip and fall hazard. Because this adjustment is not covered under your warranty, it is important that you review these instructions thoroughly before proceeding.**

---

## Final Setup - Drive Belt Tension Adjustment

The drive belt tension has been pre-set at the factory to minimize maintenance. If there are indications that the drive belt has stretched and become loose, refer to the Preventative Maintenance Chapter 7 for adjustment procedure. Symptoms of a stretched drive belt could include increased noise.

---

**NOTE: Because this adjustment is not covered under your warranty, it is important that you review these instruction thoroughly before proceeding.**

---

### Final Setup - Test Plug Procedure

Each TRACKMASTER® TMX428 Series treadmill includes an RS-232 test plug that enables you to test the operation of the treadmill without the ECG unit attached. The plug is located on the left side of the treadmill secured to the frame by Velcro®. The plug is to be used only for testing the treadmill. Do not stand on or use the treadmill while testing.



#### Front of Treadmill

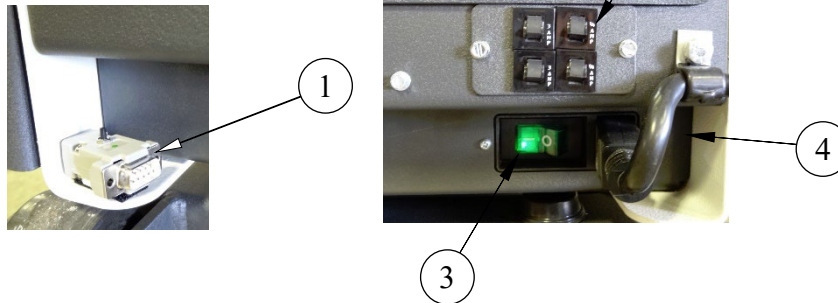

Item	Description
1	Test plug located on left side
2	Circuit breaker array
3	Main power switch
4	Incoming power cord

To use the test plug, observe the following procedure:

1. Turn the power "OFF" at the treadmill.
2. Disconnect RS232 or USB interface cable from the treadmill and plug in the test connector.
3. Press and hold the button down on the test connector and turn treadmill power "ON". Continue holding until treadmill begins to elevate.
4. Once the treadmill begins to rise, each push of the button should elevate the treadmill by 5%.
5. Once the treadmill reaches 20% elevation, the next push of the button will start the treadmill running belt.
6. Once the treadmill belt starts, each press of the button should increase speed by 2.5 mph (4 km/h)
7. Once the treadmill reaches 10.0 mph (16 km/h), each push of the button decrease the speed by 2.5 mph (4 km/h) and lower the elevation in 5% increments.
8. Once minimum speed and elevation is reached, the next press of the button should stop the treadmill running belt.

**NOTE: Successful completion of the preceding testing procedure ensures that the treadmill is fully functional and responsive to command signals.**

**NOTE: Unsuccessful completion of the preceding testing procedure indicates a problem with the setup. Call Full Vision or one of their authorized agents to trouble shoot failure of test plug procedure.**

9. Remove the test connector and place back on the Velcro® holder.
10. Reconnect the RS232 or USB interface cable from the host computer. You are ready to begin the set-up procedure prescribed by your medical test equipment supplier.

**Communication Access Location**

The communication ports are located at the very front of the treadmill near the center of the unit.

Two ports are offered with equal communication capability. The standard female RS232 port and a USB Type B port offer connectivity diversification.

You will need to install the appropriate USB driver software on your host computer to communicate with the TRACKMASTER® treadmill. The USB driver is supplied on the provided flash drive. You may download the appropriate driver based upon your computer OS at <http://www.ftdichip.com/Drivers/VCP.htm>. When connecting to the USB port, ensure port configuration is congruent with your software port identification.

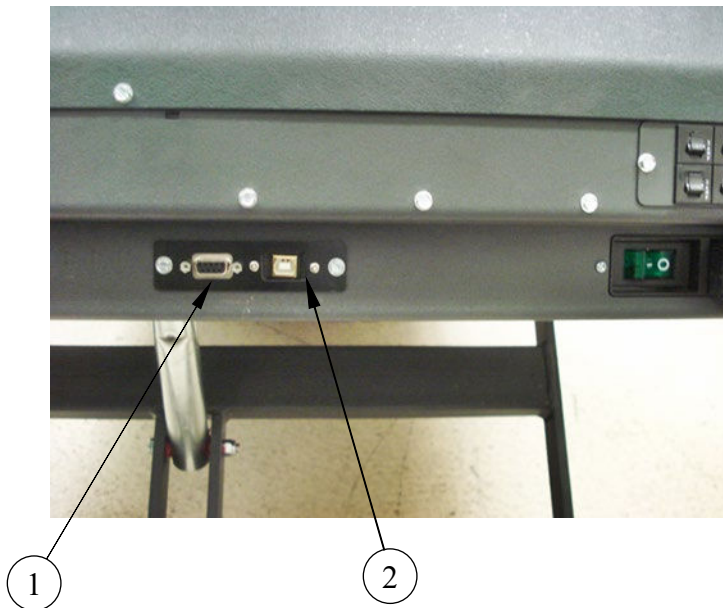

Item	Description
1	RS232 Port “Female”
2	USB “B” Port

## 6

# Operating Instructions

Before operating the TMX428 and TMX428CP, familiarize yourself with the following safety control features of the treadmills.

## Electrical Safety Tests

The electrical safety of this installation is the responsibility of the customer, not Full Vision, Inc (TRACKMASTER®). In hospitals, contact your in-house biomedical technician, electrician, or technically qualified personnel. Outside of hospital, contact your hospital affiliation of these services.

Before using the treadmill, have qualified personnel perform the test listed below:

- AC line voltage test to verify the power outlet is properly wired.
- Ground continuity test to verify all exposed metal is properly grounded.
- Leakage test to verify the equipment passes all applicable leakage tests.

Your in-house biomedical technician, electrician, or technically qualified personnel can find instruction for performing these tests in the TMX428/TMX428CP Treadmill Service Manual

## Operating Controls

The TMX428 treadmill has three operating controls: the power switch, emergency stop switch, and patient safety tether. The power switch is located on the rear panel, the emergency stop is located on the right-hand rail, and the pull tether is located on the left handrail (Optional on opposite side).

## Controlling the Treadmill

- Turn the power switch ON (|).
- Use the controlling equipment to start the treadmill, adjust the treadmill speed and grade, proceed through exercise phases, terminate the exercise session, and turn off the treadmill. Refer to the appropriate controlling equipment Operator Manual for instructions.

## Power Switch

The power switch controls the AC power to the treadmill. The ON position (|) applies power. The Off position (O) removes power.

## Emergency Stop Switch

The emergency stop switch is a safety device for use in emergency situations to stop the treadmill.

**CAUTION: When the Emergency Stop Button (ESB) is engaged or pressed in the closed position, the treadmill's running belt will coast to a stop and maintain elevation.**

To release the emergency stop switch, turn the push button ¼-turn in clockwise direction or pull to release. The treadmill will return to 0.0% elevation.

**NOTE:** Use of the Emergency Stop Switch may cause a test interruption.

## Emergency Stop Switch Check

**NOTE:** Verify proper operation of the stop switch assembly every month.

- With the belt moving at a relatively high speed, press the emergency stop switch. The treadmill's running belt will coast to a stop and maintain elevation. To release the emergency stop switch, turn the push button ¼-turn in clockwise direction or pull to release. The treadmill will return to 0.0% elevation.

- If the treadmill is used with a Host Device or for clinical testing, the operator shall be within a distance that provides easy access to the Emergency Stop Switch.

**CAUTION: When the Emergency Stop Button (ESB) is engaged or pressed in the closed position the treadmill's running belt will coast to a stop.**

- Use the controlling equipment to terminate the exercise session and turn off the treadmill.

## Patient Safety Tether Switch

The patient safety tether switch is a safety device for patient safety use in emergency situations to stop the treadmill.

**CAUTION: Activation of the patient safety tether while the treadmill is in motion, results in a controlled deceleration rate of 2.5 MPH per second to 0.0 MPH. The elevation is maintained and belt locked at 0.0 MPH for 3 minutes or until power is cycled.**

To re-attach the patient safety tether, attach clip or magnet to the original position on the switch. The treadmill will return to 0.0% elevation.

**NOTE:** Use of the Patient Safety Tether Switch may cause a test interruption.

*Wrist Strap Tether Clip Attached*



*Wrist Strap Tether Clip Detached*



*Magnetic Tether Attached*

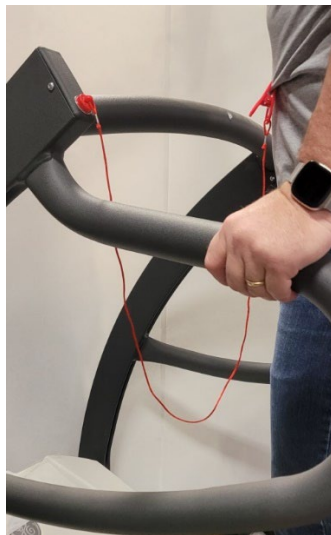

*Magnetic Tether Detached*



**Note: The patient safety tether clip needs to be seated for the treadmill to operate as designed and the “Power Up Sequence” completed. If the treadmill receives a start command**

before reaching zero elevation, the treadmill will reject the start command and will enter into an error mode. In this error mode, the treadmill will be non-responsive to all start commands. You may observe the elevation to change but belt will not start. You need to perform a main power cycle on the treadmill to come out of the error mode. During the “Power Up Sequence”, there could be a maximum delay of 45 seconds. Pressing the ESB or Patient Safety Tether activation will also serve the purpose of entering the “Power Up Sequence”.

---

**Note:** Pressing down on the RED cap of the Patient Safety Tether for greater than 3/4 seconds will result in activation of the Patient Safety Tether. Once the treadmill has reached 0.0 MPH, the treadmill enters into “Power Up Sequence” mode where it goes to the parked position. Wait until the treadmill reaches the parked position as noted above, where failure to allow it to complete the “Power Up Sequence” results in an error mode and the treadmill becomes non-responsive to all start commands.

---

**Note:** When resetting the patient safety tether clip or magnet, there may or may not be a break in communication between the host system and the treadmill.

---

## Patient Safety Tether Switch Check

**NOTE:** Verify proper operation of the patient safety tether switch assembly every month.

- With the belt moving at a relatively high speed, pull the wrist strap or magnet to activate.

**CAUTION:** Activation of the patient safety tether, the treadmill has a controlled deceleration rate of 2.5 MPH per second to 0.0 MPH and held at 0.0 MPH for 3 minutes or until power cycle.

- The running belt will have resistance preventing the free movement of the running surface. To reattach the patient safety tether, attach clip or magnet to the original position on the switch. The treadmill will return to 0.0% elevation.
- Use the controlling equipment to terminate the exercise session and turn off the treadmill.

## Treadmill Power Up Sequence Mode

The treadmill enters into “Power Up Sequence” mode while recovering from certain Stop scenarios.

During this mode the treadmill performs an internal check while returning to its parking position, i.e., zero-elevation point. Ensure NOT to press the “Start” button until the treadmill completes its Power Up Sequence. There is sometimes an audible click that can be heard once the Power Up Sequence is completed.

## Loss of Communication with the Host System

The treadmill is equipped with a RS232 or USB port to provide communication with the Stress Host system. Communication with the treadmill can be lost due to multiple factors like interface cable or connector damage, loose connection, cable pinching or entanglement etc. If there is a communication loss while the treadmill is running, the treadmill will gradually decelerate at 0.5mph/sec until stopped. The elevation is maintained, and belt remains locked for 3 mins. The communication between the Host and treadmill is lost and hence an error message will be displayed on the Host system indicating communication loss to the treadmill.

Perform a check on the communication cable, if damaged or fallen lose from its position.

Restoring the cable connection will establish communication with the Host system and the error

message on the Host will disappear. Press the “Start” button on the Host system to resume the Exercise test cycle at the speed and elevation as commanded by the Host system.

## **Loss of Communication due to Timeout**

A “Communication timeout” may occur if communication is lost for 2.5 seconds (4 seconds optional) between the Host system and the treadmill. If a communication timeout occurs while the treadmill is running, the treadmill will gradually decelerate at 0.5mph/sec until stopped. The elevation is maintained, and belt remains locked for 3 mins. The Host system may display “No Communication” momentarily, then reestablish communication. Press the “Start” button on the Host system to resume the Exercise test cycle at the speed and elevation as commanded by the Host system.

If following the above does not restart the test cycle, you need to end the test and start a new exercise test. The elevation will go to the parking position. Exercise test cycle will start (belt starts moving) at the speed and elevation as commanded by the Host system.

## Programmable Control Instructions TMX428CP

The TRACKMASTER® TMX428CP Programmable Control model is a dual purpose treadmill capable of operating for cardiac stress testing or a VO<sub>2</sub> pulmonary evaluation. The display automatically changes from a blue, full information screen (typically found on fitness treadmills), to a black screen under controlled thru communication. All control buttons on the console are disabled in this mode with the exception of the two stop buttons located at the lower left and lower right of the control. The display will revert back to the full information screen upon closing the communications.

### TESTING MODE DISPLAY

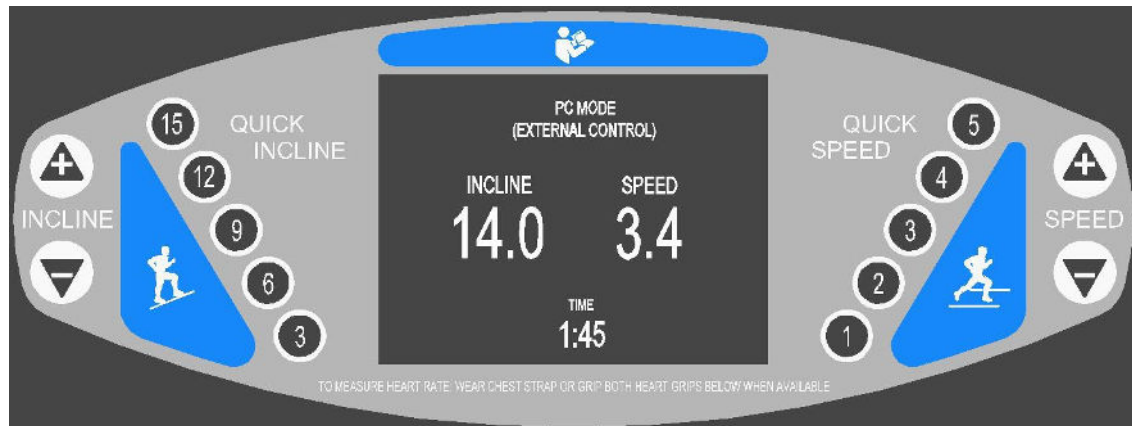

**NOTE:** The heart rate function is disabled not allowing monitoring of vitals during medical evaluation.

The TRACKMASTER® TMX428CP Control model is a full-featured, stand-alone fitness treadmill suitable for rehabilitation and general fitness applications. Additionally, it comes pre-programmed with 10 workouts, including Pre-Programmed Protocols and Interval Fitness training routines, in addition to 5 possible user defined workouts.

### MANUAL MODE DISPLAY

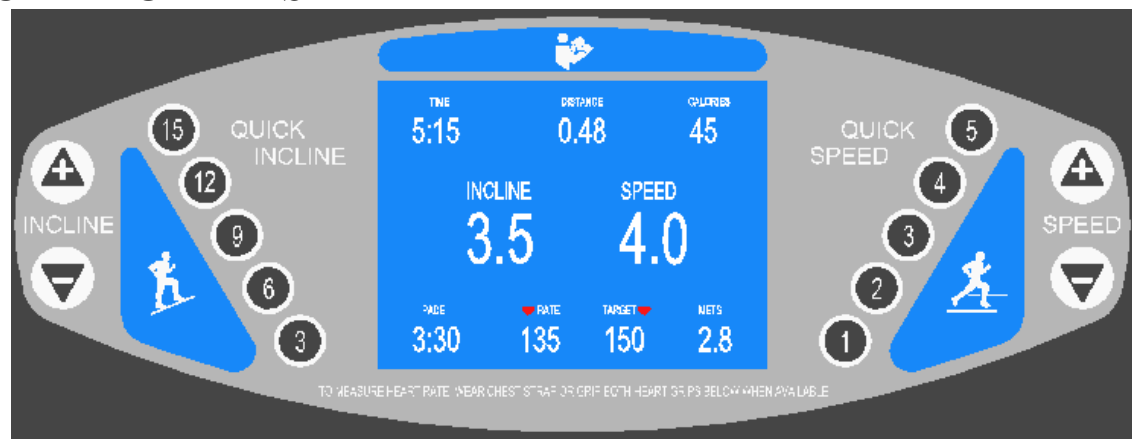

**NOTE:** The target heart rate function is only available through the use of a wireless chest strap or pulse rate watch monitoring device. This information is not intended to be stored or recorded for medical evaluation.

**Control Panel Display:** The blue display screen in the center of the console provides information on how to begin your workout and provides continuous user performance data throughout the workout session. Additionally, it serves as a user interface allowing optional input of user information when a new workout begins. The screen will prompt the user to input weight, age, and gender so that the onboard computer can calculate a more accurate calorie burn and target heart rate. Heart rate measurement is accessible through the use of the contact grips or by wearing a wireless pulse rate watch or chest strap. The display screen allows the user to simultaneously monitor: time, speed, incline, distance traveled, pace, current heart rate, calories burned and METS.

The performance and feedback information provided on the blue display screen are defined as follows:

**Time:** The elapsed time of your workout session, beginning with the initial movement of the belt and ending when the stop button is pressed.

**Speed:** The speed at which the belt is moving. The belt starts at 0.1 MPH and has a top speed of 15.0 MPH. Belt speed can be increased or decreased in 0.1 MPH. increments. This feature is capable of displaying KPH.

**Incline:** The degree of incline of the walking surface. The starting incline is 0% with a maximum of 25%. The degree of incline can be increased or decreased in .5% increments.

**Distance:** The distance traveled in miles during the duration of the workout session, beginning with the initial movement of the belt and ending when the stop button are pressed. The distance is measured in .1 of a mile. This feature is capable of displaying in Kilometers.

**Heart Rate:** The user's current heart rate calculated in beats per minute when wearing a wireless chest strap, wireless watch monitor, or by using the contact grips.

**Calories:** An approximate calculation of cumulative K-CAL expenditure for the exercise session based on your body weight and the level of difficulty at which you are exercising.

**Pace:** Displays the number of minutes needed to run one mile or kilometer.

**METS:** Displays MET level

---

**NOTE: You must attach the Patient Safety Tether lanyard strap to your wrist before pressing any other buttons on the TRACKMASTER® control.**

---

**Patient Safety Tether:** This switch is located on the console in the lower right hand portion, just right of center. It is used in combination with a lanyard and wrist cuff which is to be worn by the user at all times during the operation of the TRACKMASTER® treadmill. The opposite end of the lanyard has a plastic "C" shaped piece or magnet that engages the Patient Safety Tether, which must be in place for the machine to run. Simply insert the clip on the shaft directly behind the red cap on the switch or place the magnet back on the post. The TRACKMASTER® treadmill is designed to stop all functions upon activation of the Patient Safety Tether. Operation cannot resume until the "C" shaped clip or magnet is returned to its operational position.

## Control Panel Button Descriptions:

**Start button:** The green start button is used to begin a workout session. When a new user steps onto the machine and the startup information is displayed on the screen, pressing the start button will immediately begin a 3 second countdown of the belt start at minimum belt speed. When a user has previously selected a pre-programmed workout, pressing the start button will start the first phase of the program.

**Stop buttons:** The red hexagon shaped stop buttons are used to end an exercise session. Anytime that it is pressed during a workout session, the running belt will gently come to a stop and be locked into place for 2 minutes or until a new workout session is started. Upon pressing the stop button, the incline of the running deck will decrease to 0 percent and the cumulative user data information will displayed for 60 seconds. To start a new workout session, press the Start button or Program button.

**Enter button:** The yellow enter button is used to enter the user's weight, age, and gender when prompted by the display screen at the beginning of a workout session as well as entering data when creating or modifying workout programs.

**Cool Down button:** The blue cool down button will incrementally slow the running belt speed down by 0.1 MPH or KPH and decrease elevation by .5% elevation incrementally over 90 seconds every until the running belt stops and elevation returns to 0% elevation.

**Program / Select button:** The black program button calls up a list of pre-programmed workouts and is used to select segments of a workout when creating or modifying a workout routine.

**Speed Minus "Slower":** The triangular speed minus button decreases the speed of the running belt by 0.1 MPH or KPH each time it is pressed while the belt is moving. Pressing and holding the speed minus "slower" button while the belt is moving will decrease the speed of the running belt at an accelerated rate until it is released.

**Speed Plus "Faster":** The triangular speed faster button increases the speed of the running belt by 0.1 MPH or KPH each time it is pressed while the belt is moving. Pressing and holding the speed plus "faster" button while the belt is moving will increase the speed of the running belt at an accelerated rate until it is released.

**Quick Speed:** The (5) quick speed buttons will rapidly bring the running belt speed to the speed selected from 1.0 to 5.0 MPH or 1.0 to 5.0 KPH.

**Incline Minus:** The triangular incline minus button decreases the incline of the walking surface by 0.5 percent each time it is pressed while the running belt is operating. Pressing and holding the incline minus button while the running belt is in motion will increase the rate of the command. However, it may take a few seconds to reach the desired incline that is displayed on the information screen after the button is released.

**Incline Plus:** The triangular incline plus button increases the incline of the walking surface by .5 percent each time it is pressed while the running belt is operating. Pressing and holding the incline plus button while the running belt is in motion will increase the rate of the command. However, it may take a few seconds to reach the desired incline that is displayed on the information screen after the button is released.

**Quick Incline:** The (5) quick incline buttons will rapidly bring the running belt surface to the selected incline from 3% to 15%.

# WORKOUT GRAPHICS

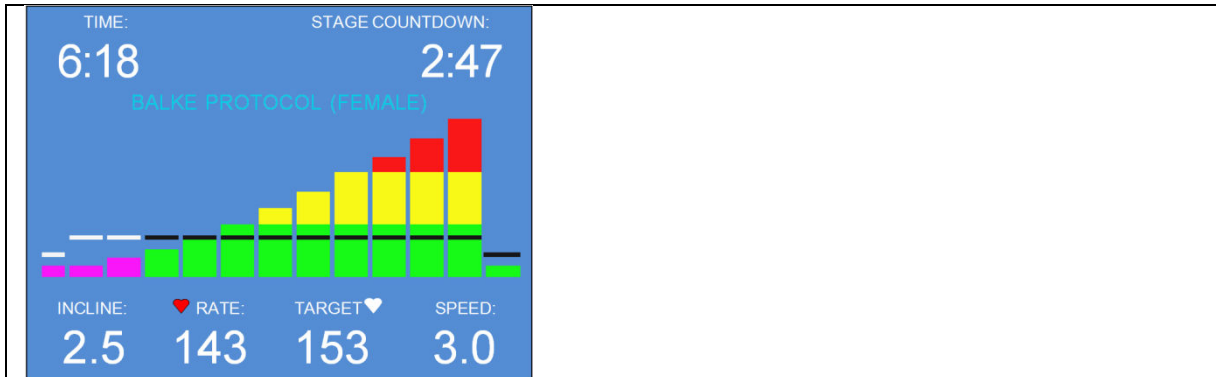

The entire workout is represented in the form of a colored bar graph which depicts increasing workout intensity as well as workout progression and current treadmill settings. These values can be displayed in either Metric or English measurements.

Segments that have been completed will turn to MAGENTA. In the example above, the first two segments of the workout have been completed leaving (7) segments yet to complete.

The GREEN portion of the bar represents an incline between 0 and 10%

The YELLOW portion of the bar represents an incline between 10% and 18%.

The RED portion of the bar represents an incline from 18% to 25%.

The BLACK horizontal bars represent the running belt speed. They will turn to WHITE when the segment is completed.

## MANUAL OPERATION:

The default start-up screen allows the user to bypass the user data by simply pressing the START button. To enter user data, complete steps 1-16. The user interface screen easily leads the user through the appropriate steps to achieve a desired operation.

<ol style="list-style-type: none"> <li>1. Press the ENTER button to input user information.</li> <li>2. Optionally, press the START button to start the treadmill in a non-defined run mode-OR-</li> <li>3. Press the PROGRAM SELECT button to view and select a Built-In routine. Go to step 15.</li> </ol>	<p>PRESS 'ENTER' ● TO INPUT USER INFORMATION</p> <p>PRESS 'START' ● TO BEGIN EXERCISE ROUTINE</p> <p>PRESS 'PROGRAM SELECT' ● TO BEGIN PROGRAM EXERCISE ROUTINE</p>
<p>If you opted to input your user information, follow the next 12 steps</p> <ol style="list-style-type: none"> <li>4. Press the + or – button until the desired age appears on the screen.</li> <li>5. Press the ENTER button to continue.</li> </ol>	<p>PRESS ▲ OR ▼ BUTTON TO INPUT YOUR AGE THEN PRESS 'ENTER' ●</p> <p>40</p>

<p>6. Press the + or – button until the desired weight appears on the screen. 7. Press the ENTER button to continue.</p>	
<p>8. Press the + or – button until the correct gender appears on the screen. 9. Press the ENTER button to continue.</p>	
<p>10. Press the + or – button until the desired heart rate appears on the screen. 11. Press START to begin walking.  <b>NOTE:</b> The target heart rate function is only available through the use of a wireless chest strap or pulse rate watch monitoring device.</p>	
<p><b>NOTE:</b> If the user exceeds the stated heart rate target, the screen will flash a warning that the target heart rate has been exceeded. The treadmill, however, will not stop. It is the responsibility of the user to take further action.</p>	
<p>12. Upon pressing the START button in step 11, the screen will advise that the belt will start in a countdown of 3 as shown at the right.</p>	
<p>13. After the belt begins to move, elevation and speed control is available through the use of the + / - keys as well as the quick speed keys on the console. 14. Press the STOP key to immediately stop your workout or press the COOL DOWN key to slowly decelerate the belt to a stop.</p>	

## BUILT-IN PROGRAM OPERATION

There are 10 pre-programmed workouts within the control. Select from (5) Pre-Programmed protocols and (5) interval training routines. To access these programs, complete the following steps: The following (5) Pre-Programmed Protocols are explained here.

15. In Step 3, the user selected the PROGRAM SELECT button to access Built-In program routines. This screen requires the user to select either Pre-Programmed Protocols, Fitness Interval workouts, or to define a custom workout by utilizing the + - buttons. When the desired program is highlighted, press the Yellow Enter button to select. If the user selects Fitness Workouts, go to Step 17. If the user selects the User Defined Program go to Step 19.

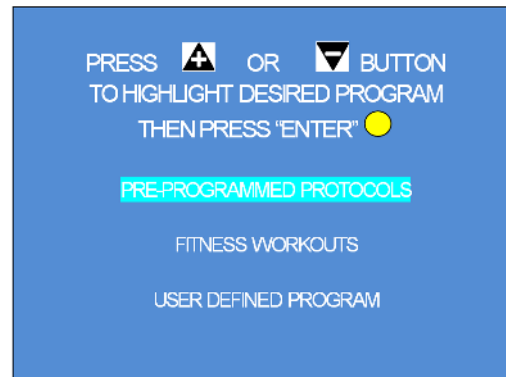

16. Press the + or – button until the desired Protocol is selected. When the desired program is highlighted, press the Green Start button to start routine. The detailed description for each Pre-Programmed Protocol below.

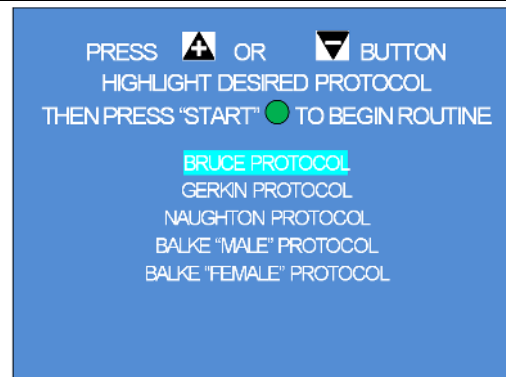

## Pre-Programmed Protocol Workout Data

Bruce Protocol				
	Time	Speed		Incline
		KPM	MPH	
Warm-up	3 min	2.7	1.7	0%
Stage 1	3 min	2.7	1.7	10%
Stage 2	3 min	4.0	2.5	12%
Stage 3	3 min	5.7	3.4	14%
Stage 4	3 min	6.8	4.2	16%
Stage 5	3 min	8.1	5.0	18%
Stage 6	3 min	8.9	5.5	20%
Stage 7	3 min	8.9	6.0	22%
Cool-down	3 min	2.7	1.7	0%

### Gerkin Protocol (Firefighter's Test)

	Time	Speed		Incline
		KPM	/ MPH	
Warm-up	3 min	4.8	3.0	0%
Stage 1	1 min	7.2	4.5	0%
Stage 2	1 min	7.2	4.5	2%
Stage 3	1 min	8.0	5.0	2%
Stage 4	1 min	8.0	5.0	4%
Stage 5	1 min	8.8	5.5	4%
Stage 6	1 min	8.8	5.5	6%
Stage 7	1 min	9.7	6.0	6%
Stage 8	1 min	9.7	6.0	8%
Stage 9	1 min	10.5	6.5	8%
Stage 10	1 min	10.5	6.5	10%
Stage 11	1 min	11.3	7.0	10%
Stage 12	1 min	11.3	7.0	12%
Stage 13	1 min	12.0	7.5	12%
Stage 14	1 min	12.0	7.5	14%
Stage 15	1 min	12.9	8.0	14%
Stage 16	1 min	12.9	8.0	16%
Cool-down	3 min	2.7	1.7	0%

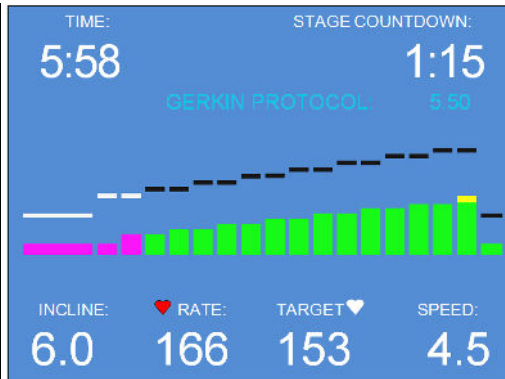

### Naughton Protocol

	Time	Speed		Incline
		KPM	/ MPH	
Warm-up	2 min	1.6	1.0	0%
Stage 1	2 min	3.2	2.0	0%
Stage 2	2 min	3.2	2.0	3.5%
Stage 3	2 min	3.2	2.0	7.0%
Stage 4	2 min	3.2	2.0	10.5%
Stage 5	2 min	3.2	2.0	14.0%
Stage 6	2 min	3.2	2.0	17.5%
Cool-down	3 min	1.6	1.0	0%

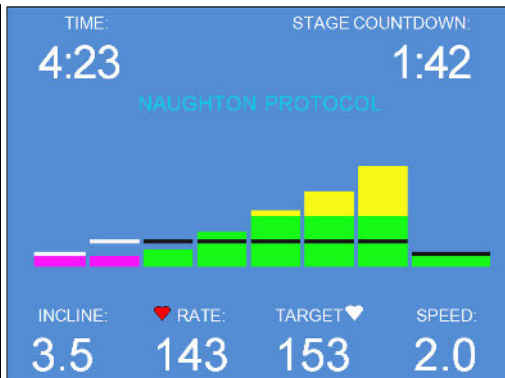

### Balke- Male

	Time	Speed		Incline
		KPM	MPH	
Warm-up	2 min	2.7	1.7	0%
Stage 1	1 min	5.3	3.3	0%
Stage 2	1 min	5.3	3.3	2%
Stage 3	1 min	5.3	3.3	3%
Stage 4	1 min	5.3	3.3	4%
Stage 5	1 min	5.3	3.3	5%
Stage 6	1 min	5.3	3.3	6%
Stage 7	1 min	5.3	3.3	7%
Stage 8	1 min	5.3	3.3	8%
Stage 9	1 min	5.3	3.3	9%
Stage 10	1 min	5.3	3.3	10%
Stage 11	1 min	5.3	3.3	11%
Stage 12	1 min	5.3	3.3	12%
Stage 13	1 min	5.3	3.3	13%
Stage 14	1 min	5.3	3.3	14%
Stage 15	1 min	5.3	3.3	15%
Stage 16	1 min	5.3	3.3	16%
Stage 17	1 min	5.3	3.3	17%
Stage 18	1 min	5.3	3.3	18%
Stage 19	1 min	5.3	3.3	19%
Stage 20	1 min	5.3	3.3	20%
Stage 21	1 min	5.3	3.3	21%
Stage 22	1 min	5.3	3.3	22%
stage 23	1 min	5.3	3.3	23%
stage 24	1 min	5.3	3.3	24%
Stage 25	1 min	5.3	3.3	25%
Cool-Down	3min	2.7	1.7	0%

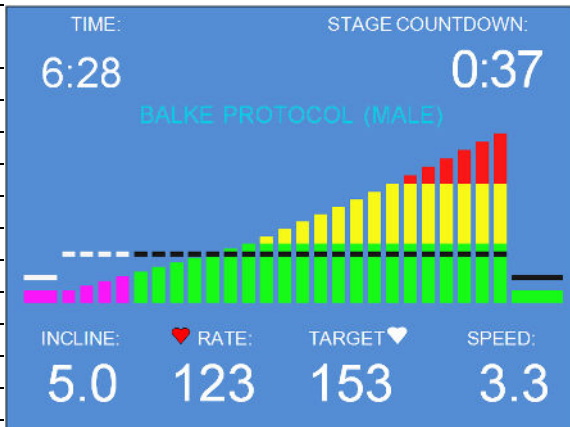

### Balke- Female

	Time	Speed		Incline
		KPH	MPH	
Warm-up	2 min	2.7	1.7	0%
Stage 1	1 min	4.8	3.0	0%
Stage 2	1 min	4.8	3.0	2.5%
Stage 3	1 min	4.8	3.0	5.0%
Stage 4	1 min	4.8	3.0	7.5%
Stage 5	1 min	4.8	3.0	10%
Stage 6	1 min	4.8	3.0	12.5%
Stage 7	1 min	4.8	3.0	15.0%
Stage 8	1 min	4.8	3.0	17.5%
Stage 9	1 min	4.8	3.0	20.0%
Stage 10	1 min	4.8	3.0	22.5%
Stage 11	1 min	4.8	3.0	25.0%
Cool-Down	3min	2.7	1.7	0%

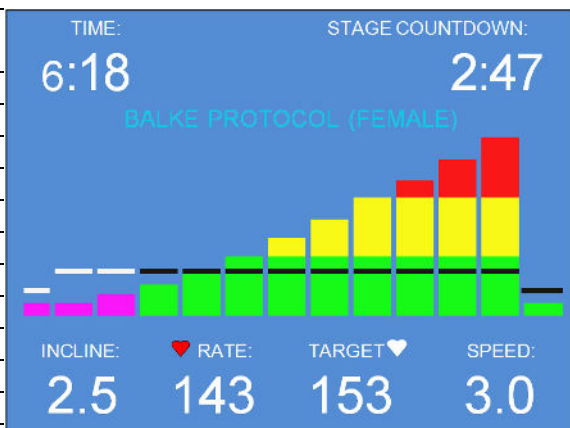

## Pre-Programmed Fitness Workout Data

17. To access Pre-Programmed Fitness Workouts, use the + / - key to highlight the selection and press the Yellow Enter button.



18. The screen at the right shows the (5) Fitness workouts the user can choose from. Select the desired Fitness Workout by pressing the + / - button then press the Yellow Enter button to input user information or press the Green Start button to begin workout.

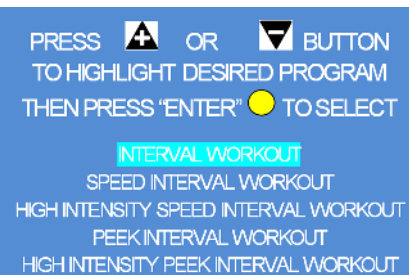

**NOTE:** Any of the Fitness Interval Training programs can be altered in intensity merely by pressing + / - for belt speed or incline. The control will remember that setting as it transitions from one segment to the next.

## INTERVAL WORKOUT

	Time	Speed		Incline
		KPH	MPH	
Warm-up	1.5 min	4.8	3.0	0%
Stage 1	1.5 min	5.6	3.5	5%
Stage 2	1.5 min	4.8	3.0	2%
Stage 3	1.5 min	5.6	3.5	7%
Stage 4	1.5 min	4.8	3.0	5%
Stage 5	1.5 min	5.6	3.5	9%
Stage 6	1.5 min	4.8	3.0	5%
Stage 7	1.5 min	5.6	3.5	12%
Stage 8	1.5 min	4.8	3.0	5%
Stage 9	1.5 min	5.6	3.5	12%
Cool-Down	3.0 min	4.8	3.0	0%

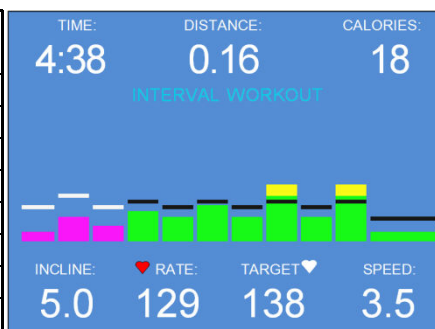

### SPEED INTERVAL WORKOUT

	Time	Speed		Incline
		KPH	MPH	
Warm-up	1.5 min	4.0	2.5	0%
Stage 1	0.5 min	6.4	4.0	0%
Stage 2	1.5 min	4.0	2.5	0%
Stage 3	0.5 min	6.4	4.0	0%
Stage 4	1.5 min	4.0	2.5	0%
Stage 5	0.5 min	6.4	4.0	0%
Stage 6	1.5 min	4.0	2.5	0%
Stage 7	0.5 min	6.4	4.0	0%
Stage 8	1.5 min	4.0	2.5	0%
Stage 9	0.5 min	6.4	4.0	0%
Stage 10	1.5 min	4.0	2.5	0%
Stage 11	0.5 min	6.4	4.0	0%
Stage 12	1.5 min	4.0	2.5	0%
Stage 13	0.5 min	6.4	4.0	0%
Stage 14	1.0 min	4.0	2.5	0%
Cool-Down	3.0 min	3.2	2.0	0%

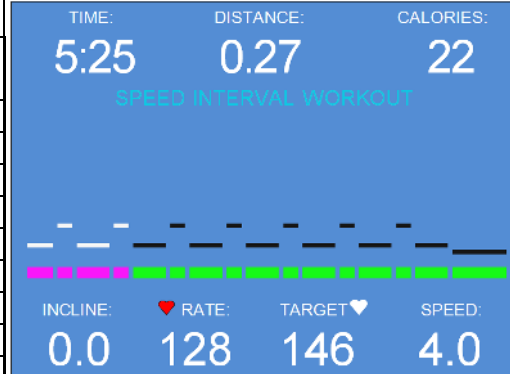

### HIGH INTENSITY SPEED INTERVAL WORKOUT

	Time	Speed		Incline
		KPH	MPH	
Warm-up	1.5 min	4.0	2.5	0%
Stage 1	1.5 min	6.4	4.0	0%
Stage 2	0.5 min	4.0	2.5	0%
Stage 3	1.5 min	6.4	4.0	0%
Stage 4	0.5 min	4.0	2.5	0%
Stage 5	1.5 min	6.4	4.0	0%
Stage 6	0.5 min	4.0	2.5	0%
Stage 7	1.5 min	6.4	4.0	0%
Stage 8	0.5 min	4.0	2.5	0%
Stage 9	1.5 min	6.4	4.0	0%
Stage 10	0.5 min	4.0	2.5	0%
Stage 11	1.5 min	6.4	4.0	0%
Stage 12	0.5 min	4.0	2.5	0%
Stage 13	1.5 min	6.4	4.0	0%
Stage 14	1.0 min	4.0	2.5	0%
Cool-Down	3.0 min	3.2	2.0	0%

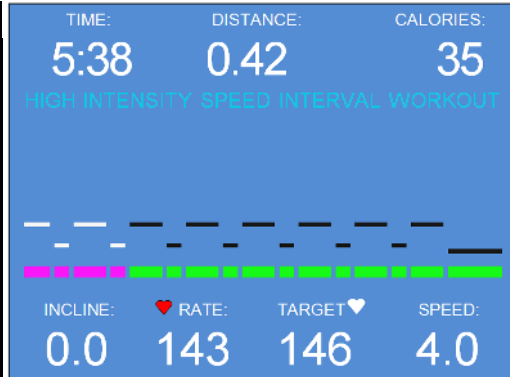

### PEAK INTERVAL WORKOUT

	Time	Speed		Incline
		KPH	MPH	
Warm-up	1.5 min	4.0	2.5	0%
Stage 1	0.5 min	6.4	4.0	5%
Stage 2	1.5 min	4.0	2.5	3%
Stage 3	0.5 min	6.4	4.0	5%
Stage 4	1.5 min	4.0	2.5	3%
Stage 5	0.5 min	6.4	4.0	5%
Stage 6	1.5 min	4.0	2.5	3%
Stage 7	0.5 min	6.4	4.0	7%
Stage 8	1.5 min	4.0	2.5	5%
Stage 9	0.5 min	6.4	4.0	9%
Stage 10	1.5 min	4.0	2.5	7%
Stage 11	0.5 min	6.4	4.0	12%
Stage 12	1.5 min	4.0	2.5	10%
Stage 13	0.5 min	6.4	4.0	12%
Stage 14	1.0 min	4.0	2.5	3%
Cool-Down	3.0 min	3.2	2.0	0%

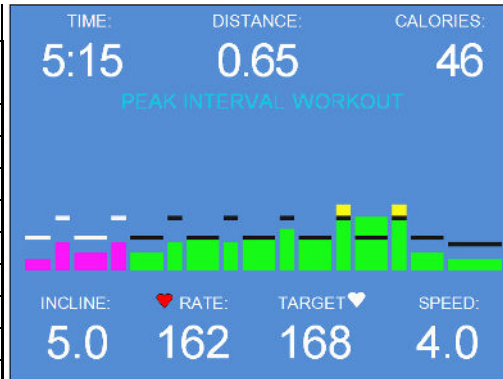

### HI INTENSITY PEAK INTERVAL WORKOUT

	Time	Speed		Incline
		KPM	MPH	
Warm-up	1.5 min	4.0	2.5	0%
Stage 1	1.5 min	6.4	4.0	5%
Stage 2	0.5 min	4.0	2.5	3%
Stage 3	1.5 min	6.4	4.0	5%
Stage 4	0.5 min	4.0	2.5	3%
Stage 5	1.5 min	6.4	4.0	5%
Stage 6	0.5 min	4.0	2.5	3%
Stage 7	1.5 min	6.4	4.0	7%
Stage 8	0.5 min	4.0	2.5	5%
Stage 9	1.5 min	6.4	4.0	9%
Stage 10	0.5 min	4.0	2.5	7%
Stage 11	1.5 min	6.4	4.0	12%
Stage 12	0.5 min	4.0	2.5	10%
Stage 13	1.5 min	6.4	4.0	12%
Stage 14	1.0 min	4.0	2.5	3%
Cool-Down	3.0min	3.2	2.0	0%

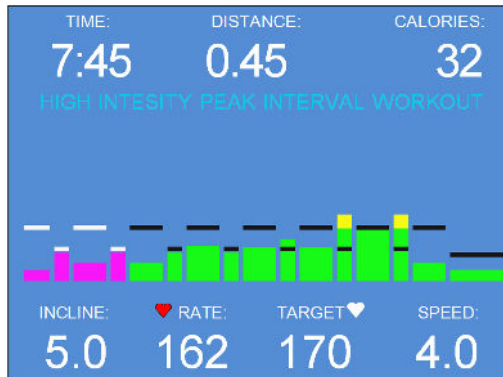

## User Defined Programming

19. To access User Defined menu, use the + / - key to highlight the selection and press the Yellow enter button.

**NOTE:** Any of the User Defined Programs can be altered in intensity merely by pressing + / - for belt speed or incline. The computer will remember that setting as it transitions from one segment to the next.

20. The screen at the right shows the (5) Custom Workouts the user can choose from. The control has room for 10. Select the desired Custom Workout by pressing the + / - button then press the Green Start button to begin or press the Yellow Enter button to modify an existing workout. If no workouts exist and you press the Start button, Screen 21 will appear.

21. Press the + / - buttons to input the variables a field. Make sure your variable value is correct before pressing the Black Program Select button. Upon pressing this button, the cursor will advance to the next variable field. Repeat the steps above for all 3 fields. Press the Green Start button to save the routine.

PRESS ▲ OR ▼ BUTTON  
TO HIGHLIGHT DESIRED PROGRAM  
THEN PRESS "ENTER" ●

PRE-PROGRAMMED PROTOCOLS

FITNESS WORKOUTS

**USER DEFINED PROGRAM**

---

PRESS ▲ OR ▼ BUTTON  
HIGHLIGHT DESIRED PROGRAM  
THEN PRESS "START" ● TO BEGIN ROUTINE

**CUSTOM WORKOUT 1**

CUSTOM WORKOUT 2

CUSTOM WORKOUT 3

CUSTOM WORKOUT 4

CUSTOM WORKOUT 5

TO MODIFY EXISTING PROGRAM  
SELECT "ENTER" ●

---

PRESS ▲ OR ▼ BUTTON  
TO SET TIME, ELEVATION, SPEED  
PRESS "PROGRAM SELECT" ● TO  
ADVANCE AFTER EACH INPUT

STAGE 1 OF 10

TIME (SECONDS):	000
ELEVATION (% GRADE):	00.0
SPEED (MPH):	00.0

THEN PRESS "START" ● TO SAVE

# Preventive Maintenance

Regular cleaning and maintenance is essential to keep your TRACKMASTER® treadmill operating at its best for many years. We recommend that you record all maintenance and service in a log (as shown in Appendix A).



**CAUTION:** Before cleaning the device turn the main power switch to OFF and disconnect the treadmill from its power outlet. Never use wet cleaning materials near a power source; you could suffer an electrical shock.

To preserve the condition of your warranty, make sure that all repair procedures (other than normal maintenance) are performed by an authorized and qualified service provider. Contact customer support with any questions at (316) 283-3344.

Use only TRACKMASTER® replacement parts. Using other parts may void your warranty and may cause your treadmill to malfunction.

**NOTE:** Replacement Parts need to be ordered through the manufacturer of the operating equipment to ensure BASIC SAFETY and ESSENTIAL PERFORMANCE with regard to ELECTROMAGNETIC DISTURBANCES for the EXPECTED SERVICE LIFE.

## Reprocessing Instructions

To reprocess the treadmill between each patient use, follow the reprocessing instructions located in Appendix B.

## Daily Maintenance

- Ensure that the treadmill is functioning properly.
- Visual inspection of treadmill and walking belt for damage and wear

## Weekly Maintenance

- Vacuum around and under the treadmill. Clean all exposed surfaces with a vacuum cleaner. Avoid moving the treadmill from its original position as moving it will compromise the original belt tracking setting.
- Check running belt tension.
- Observe running belt tracking, correct as required.

## Monthly Maintenance

- Inspect and clean the belt.

## Semiannual Maintenance

- Evaluate the condition of the deck and belt.
- Adjust the belt to assure proper alignment.
- Check running belt adjustment.
- Check drive belt tension adjustment.
- Clean and lubricate the treadmill elevation screw.
- Clean the interior of the motor electrical enclosure as needed.

---

**NOTE: Use only TRACKMASTER® replacement parts. Using other parts may void your warranty and may cause your treadmill to malfunction.**

---

## Belt Cleaning and Inspection

1. Turn treadmill main power switch ON.
2. Start treadmill at 0.5 MPH. With a damp small towel wipe excessive dirt from running belt keeping the towel in the center of the length of the treadmill. Avoid getting the towel near the rear roller.
3. When belt is clean stop treadmill.
4. Inspect running belt for tears or nicks. If damaged, replace the belt.
5. Perform Running Belt Tracking Adjustment and Belt Tension Adjustment.

## Running Belt Tracking Adjustment

This procedure requires the following tool:

- ¼" Allen wrench

---

**NOTE: Because this adjustment is not covered under your warranty, it is important that you review these instructions thoroughly before proceeding.**

---

The patented MasterTrack® Belt Tracking System significantly reduces the need to adjust the belt on your treadmill. However, when you operate your treadmill for the first time, you may need to adjust the tracking of the belt to conform to your floor. You may also need to adjust the tracking if you move the machine to another location.

Your running belt should remain centered, although a slight amount of movement to the left or right is normal during use. Do not allow the running belt to travel all the way to either side.

To adjust the belt tracking, do the following:

1. Turn the treadmill's power switch to ON.
2. Increase the speed to 3.0 mph (4.8 km/h).
3. Observe the left side of the running belt as it travels over the rear roller. If the belt runs to the right side of the roller, turn the right bolt 1/8 turn clockwise, and turn the left bolt 1/8 turn counterclockwise.

---

**NOTE: When tightening one side of the belt, loosen the opposite side one-half as much. This procedure provides finer control, with a smaller impact on the belt tension.**

---

Check the belt after 2 minutes, with the treadmill running at approximately 7.0 mph (11.3 km/h). If the belt does not correct itself, continue with slight turns until the belt is in the center of the rear roller. If the belt runs toward the left side of the roller, reverse the adjustments.

---

**NOTE: Uneven floors accelerate belt misalignment. This situation may require more frequent adjustment to prevent belt damage.**

---

## Running Belt Tension Adjustment

The running belt may stretch and loosen with regular use. This looseness is noticeable when the belt tends to hesitate or stick. Adjust the tension on the belt by following the procedure and referring to the illustration below.

1. Turn the treadmill's power switch to ON.
2. Start treadmill and increase to 1.0 mph (1.6 km/h).
3. Start walking on the treadmill, grab side handrail and apply pressure with your foot to create resistance on running belt.
4. If running belt hesitates or slips on front drive roller, tighten both tension bolts  $\frac{1}{2}$  turn (clockwise).
5. Repeat steps 2 thru 4 until running belt stops slipping.

---

**NOTE: When running belt is too tight, the edge of belt will curl, causing premature running belt failure.**

---

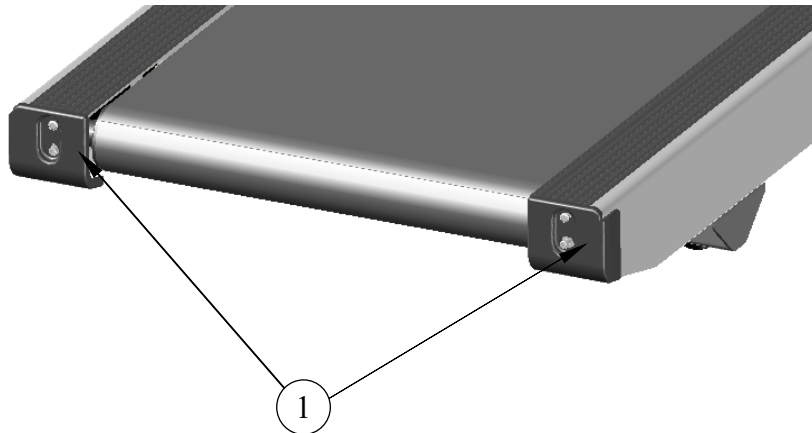

Item	Description
1	Tension Bolts

---

**NOTE: Operating the treadmill at a high-speed application may cause hesitation or slippage of the running belt with each foot plant. This could be a sign of the backing of the running belt breaking down causing a premature failure.**

---

## Drive Belt Tension Adjustment

This procedure requires the following tool:

- 1/8" Allen Wrench
- 3/4" Socket or Box Wrench
- 3/4" Wrench
- Tape measure

---

**NOTE: Because this adjustment is not covered under your warranty, it is important that you review these instructions thoroughly before proceeding.**

---

**NOTE: The drive belt may stretch and loosen with regular use. This looseness may result in a flapping noise under the hood.**

---

1. Remove the (5) #10-32 screws located on the bottom hood with 1/8" Allen wrench.
2. With the 3/4" socket and wrench loosen the TENSION ADJUSTMENT back nut.
3. Press down on drive belt between motor and front roller with approximately 5 lbs of force to achieve 1/4" to 3/8".
4. If adjustment is need using a 3/4" wrench turn the TENSION BOLT clockwise to tighten. To loosen, turn the wrench counterclockwise.
5. Make small adjustment until the drive belt deflects approximately 1/4" to 3/8"; tighten the TENSION ADJUSTMENT back nut.

---

**NOTE: Failure to lock the TENSION ADJUSTMENT back nut will allow the drive belt tension to become loose.**

---

6. When the treadmill is properly adjusted, reinstall the hood with (5) #8-32 screws.

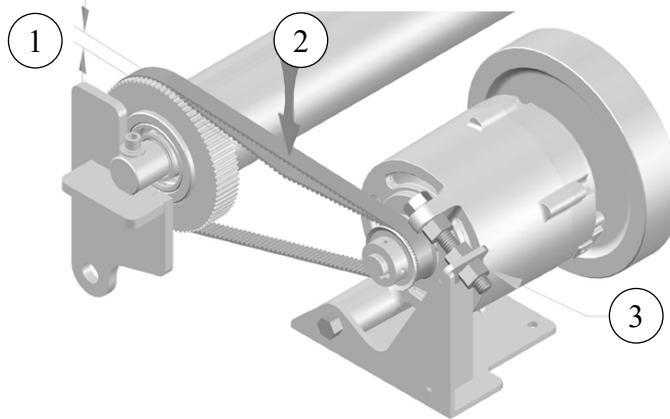

Item	Description
1	1/4 to 3/8 Deflection
2	5 LBS
3	Tension adjustment back nut.

---

**NOTE: When drive belt is over tensioned, the belt tension will cause motor noise. This could result in premature motor life.**

---

## Exterior Care

The powder-coat finish on your treadmill is an extremely durable finish and requires minimal care. Do not allow perspiration to build up on your treadmill. Wipe the unit daily. (Refer to Appendix B Reprocessing Instructions)

- Use a moist cloth to wipe the surface clean; do not allow liquids to enter the system. All cleaning agents and disinfectants used in hospitals and containing up to 70% alcohol are suitable. If liquids have entered the system, notify service to have the system inspected for damage before it is used again.
- DO NOT use disinfection with a phenol base or peroxide compound to disinfect the external surface.

## Elevation Screw Lubrication

The Elevation Screw must be cleaned and lubricated every 6 months to maintain proper operation of the treadmill. Failure to perform this maintenance function will result in premature wear and ultimate failure of the lift mechanism.

This procedure requires the following tools:

- TRACKMASTER<sup>®</sup> grease (Part # 317-160-165)
  - Clean, lint-free cloth
  - Small paint brush
1. Raise the treadmill to its maximum elevation.
  2. Turn the main power switch to the OFF position and unplug the treadmill from its outlet.
  3. Using a lint-free cloth, remove the old lubricant and accumulated dust from the elevation screw.
  4. Use a small brush to reapply a thin coat of grease to the threads of the elevation screw. Do not use too much grease—the excess could squeeze onto the floor and create a slip-and-fall hazard.
  5. Plug treadmill power cord back into the power source outlet. Cycle the main power switch to the ON position and allow the treadmill to return to the parked position.
  6. Return the unit to service.

## Running Deck Maintenance

The TRACKMASTER<sup>®</sup> running deck is maintenance-free and offers two running deck surfaces to double the life of ordinary treadmills.

---

**NOTE: Do not use silicone sprays to wax your treadmill deck. Using silicone sprays will void the warranty. Such sprays can bring about surface changes that may result in hesitation or excessive belt slip.**

**Prolonged use in high-speed running may cause hesitation or slippage on each foot plant. Inspect the running deck for factory lubrication on running surface.**

**If running deck surface becomes grooved due to wear, it can be renewed by flipping the deck to the opposite side.**

---



# Product Requirements

## *FG0495 Smart Power Supply*

### INTRODUCTION

The TMX428, TMX428CP Smart Power Supply Board (SPSB) treadmill control provides a means of controlling belt speed and elevation for the treadmill through the use of either an RS-232 serial port or USB port. The communication protocol is based on the industry standard. In addition to the physical interfaces with the controlling system (PC), the motor controller and elevation motor, the UPS also includes an interface to an emergency stop switch and an SD card. The UPS supplies interfaces with a console, a soft stop switch, an output expansion port, and a low voltage fan that will not be covered in this document.

### SCOPE

This document only applies to the electronic control for the TMX428 & TMX428CP. Specifications for the mechanical treadmill, elevation motor assembly, belt motor and motor controller are not covered in this document.

### OPERATIONAL OVERVIEW

When power is applied to the unit, the UPS reads the contents of the non-volatile memory and verifies the calibration contents with a checksum. If the contents are not valid, the calibration constants are set to non-operational values and the unit is put into a state where operation is suspended pending re-calibration.

If the contents are valid, the unit enters a startup mode where the system checks to see if it should enter Self-test mode (described in the Self-test MODE section) and begins to find the zero elevation point by turning on the elevation motor in the down direction. If motion is not detected for two seconds, the system assumes that the lower elevation limit has been reached. During the “elevation zeroing” time, if a command to start the belt is received from the PC, it is assumed that the PC is not aware of the UPS power cycle and the unit will enter a non-responsive state (waiting for either a communication timeout or a stop command). If the elevation limit is found without receiving a start belt command, the UPS enters the operational mode with a set speed and set elevation of zero.

In operational mode, the unit continuously controls the belt speed output, the belt enable output, and the outputs to raise or lower the elevation based on the current set points for speed and elevation. Through the use of either communication port, the unit accepts commands to modify the belt state, the belt speed, and the deck elevation. The current state of the control may also be queried through the use of this serial port. As commands are received to change the set point speed or set point grade, they are checked for format and range. Pending approval, the new set points are adopted and adjustments are made to the state of the outputs.

Speed control is done in a closed loop that monitors the belt speed using two different speed references. The first is a magnetic reed switch located on the motor side of the belt pulley, and the second is a speed reference supplied by the motor controller. A speed calibration is required to provide a target speed output for a given set point. After the initial target is reached, the speed inputs are constantly monitored to make adjustments to the speed output and to detect over speed, zero speed, or speed sensor comparison fault conditions. In the case of a fault condition, the belt is stopped and operation is suspended.

Elevation position control is done using relays to turn on the elevation motor in the up or down direction depending on the current set point. A micro switch input is used to determine the position of the elevation motor by counting revolutions of the elevation motor's internal gearing. An elevation calibration is required to provide an accurate number of counts from zero to full elevation. No closed loop control is done for positioning elevation.

Power may be removed from the unit by opening the normally closed switch connected to the emergency stop input, or by removing AC power from the system. In both cases, the outputs will be put into a non-energized state that will correspond to the belt being shut off and the elevation motor being disengaged.

## SOFTWARE REQUIREMENTS

### SPEED CONTROL

There are two outputs required for speed control. The belt enable output must be energized to put the belt into a run mode. The speed control output is a 4kHz 1024 count pulse width modulated (PWM) output supplied directly to the motor controller. Based on calibration, the speed is controlled by outputting a PWM speed reference to the motor controller and enabling the belt run output. The speed inputs are averaged over a two second period to provide measured speed accuracy of 0.01 MPH or less.

If the speed of either input is measured to be more than 0.5 MPH over the set point, or the difference between speed inputs is measured to be more than 0.5 MPH, the belt will shut off automatically. If the speed measured is more than 3.0 MPH over the set point, the belt enable signal will be turned off immediately. If the motor controller activates a fault signal to the UPS, the system will shut down immediately.

If the measured speed is within range, it is used to make minor adjustments to the speed output when it is determined that the actual speed and measured speed differ by more than 0.08 MPH. These small adjustments (1:1024) are only allowed to be at 4 second intervals to provide for the settle time of the motor and heavily averaged speed input.

### ELEVATION CONTROL

The elevation position is constantly monitored by counting and recording changes in the state of the elevation micro switch sensor. Each de-bounced state is counted as positive if the elevation motor is engaged in the up direction and negative if it is engaged in the down direction. Using this count and the calibration numbers, the elevation position is controlled by turning on the motor in the desired

direction and counting until the target number of counts has been reached. At that time, the elevation motor is disengaged until another set point position is requested

## COMMUNICATION HARDWARE (RS-232 Option)

- DB9 Connector 9-pin PC/AT Style
 

Pin	Description
2	Transmit Data
3	Receive Data
5	Signal Ground
- RS232 (+/- 10V)
- 4800 Baud
- No Parity
- 8 Data Bits
- 1 Stop Bit
- Full Duplex

## COMMUNICATION HARDWARE (USB Option)

- PC USB Host Port
- UPS USB Peripheral Port Mini-B Connector
- FTDI FT232RL Virtual Communication Port Driver required
- 4800 Baud
- No Parity
- 8 Data Bits
- 1 Stop Bit
- Full Duplex

## COMMAND PROTOCOL

The Trackmaster Serial Communications Protocol consists of two types of commands, which are INPUT COMMANDS and STATUS REQUESTS. When a command is sent to the serial port, it is decoded and executed. The corresponding acknowledgement is then transmitted via the serial port. The controller transmits acknowledgments and data only in response to a command.

### A - INPUT COMMANDS

#### ASCII CODES

HEX	DECIMAL
-----	---------

- |        |   |
|--------|---|
| A0 160 | - Start Belt - Communication Disconnect Stop Enabled (Note 1)     |
| A1 161 | - Start Belt - Communication Disconnect Stop Disabled (Note 2)    |
| A2 162 | - Stop Belt   |
| A3 163 | - Set speed to the next 4 bytes of ASCII data (Note 3)            |
| A4 164 | - Set Elevation to the next 4 bytes of ASCII data (Note 4)        |
| A5 165 | - Set Time to the next 4 bytes of ASCII data (Note 5)             |
| A6 166 | - Set Protocol to the next 2 bytes of ASCII data (Note 5)         |
| A7 167 | - Set Stage to the next 2 bytes of ASCII data (Note 5)            |
| A8 168 | - Reset Distance, Total Time, and Energy to 0 (Note 5)            |
| A9 169 | - Set Weight to the next 4 bytes of ASCII data (Note 5)           |
| AA 170 | - Auto Stop - Sets speed and elevation to minimum and stops belt. |
| AB 171 | - Auto Cool Down - Sets speed and elevation to minimum.           |

AC 172 - Toggle Transmit Acknowledge Data Flag (Note 6)

## **B - INPUT COMMAND ACKNOWLEDGEMENT**

### ASCII CODES

HEX        DECIMAL

B0 176 - Ack. Start Belt - Communication Disconnect Stop Enabled  
 B1 177 - Ack. Start Belt - Communication Disconnect Stop Disabled  
 B2 178 - Ack. Stop Belt  
 B3 179 - Ack. Set Speed  
 B4 180 - Ack. Set Elevation  
 B5 181 - Ack. Set Lap or Stage Time (Note 7)  
 B6 182 - Ack. Set Protocol (Note 7)  
 B7 183 - Ack. Set Stage (Note 7)  
 B8 184 - Ack. Reset Distance, Total Time, and Energy (Note 7)  
 B9 185 - Ack. Set Weight (Note 7)  
 BA 186 - Ack. Auto Stop  
 BB 187 - Ack. Auto Cool Down  
 BC 188 - Ack. Toggle Transmit Acknowledge Command Data Flag  
 BE 190 - Input Command Data Out of Range  
 BF 191 - Illegal command or command not recognized

## **C - STATUS REQUEST**

### ASCII CODES

HEX        DECIMAL

C0 192 - Xmit Belt Status  
 C1 193 - Xmit Current Actual Speed  
 C2 194 - Xmit Current Actual Elevation  
 C3 195 - Xmit Current Set Speed  
 C4 196 - Xmit Current Set Elevation  
 C5 197 - Xmit Current Time (Note 8)  
 C6 198 - Xmit Total Time (Note 8)  
 C7 199 - Xmit Current Distance (Note 8)  
 C8 200 - Xmit Current Protocol (Note 8)  
 C9 201 - Xmit Current Stage (Note 8)  
 CA 202 - Xmit Current Weight (Note 8)  
 CB 203 - Xmit Current Calories (Note 8)  
 CC 204 - Xmit Current Total VO2 (Note 8)  
 CD 205 - Xmit Current Mets (Note 8)

## **D - STATUS RESPONSE**

### ASCII CODES

HEX        DECIMAL

D0 208 - Ack. Belt Status followed by 1 byte of data

	31h = Belt Stopped
	32h = Belt Started Comm. Disconnect Stop Enabled
	33h = Belt Started Comm. Disconnect Stop Disabled
D1 209	- Current Belt Speed follows as 4 bytes of ASCII data (Note 3)
D2 210	- Current Elevation follows as 4 bytes of ASCII data (Note 4)
D3 211	- Current Set Belt Speed follows as 4 bytes of ASCII data (Note 3)
D4 212	- Current Set Elevation follows as 4 bytes of ASCII data (Note 4)
D5 213	- Current Lap Time follows as 4 bytes of ASCII data (Note 9)
D6 214	- Current Total Time follows as 4 bytes of ASCII data (Note 9)
D7 215	- Current Distance follows as 4 bytes of ASCII data (Note 9)
D8 216	- Current Protocol follows as 2 bytes of ASCII data (Note 9)
D9 217	- Current Stage follows as 2 bytes of ASCII data (Note 9)
DA 218	- Current Weight follows as 4 bytes of ASCII data (Note 9)
DB 219	- Current Calories follow as 4 bytes of ASCII data (Note 9)
DC 220	- Current Total VO2 follows as 4 bytes of ASCII data (Note 9)
DD 221	- Current Mets follow as 4 bytes of ASCII data (Note 9)

## COMMUNICATION NOTES

Note 1 - The Communication Disconnect Stop Enable mode is a safety feature that stops the belt when a command is not received from the host within 0.5 seconds.

Note 2 - The Communication Disconnect Stop Disable mode allows the belt to run without sustained communication at 0.5 second intervals.

Note 3 - All speed formats are 4-digit ASCII characters in tenths of distance per hour. For instance, to set the speed to 4.0 MPH, the set speed command would be followed by 0040.

Note 4 - All elevation formats are 4-digit ASCII characters in tenths of percent inclination. The last digit must be ASCII 0 or 5. For instance, to set the elevation to 5%, the set elevation command would be followed by 0050. An attempt to send a value that is not in a half percent increment (e.g. 4.3%) will result in a data out of range reply.

Note 5 - These Input commands sent by the host are accepted by the treadmill, but not implemented functionally. For instance, a command to set the weight to 150 pounds will be accepted but will not be used. Further queries of the weight will return 0.

Note 6 - The toggle transmit acknowledge data flag is initially cleared. When set by sending the toggle transmit acknowledge command, the output response will always be followed by the input string received from the host. Sending this command when the flag is set will result in it being cleared again.

Note 7 - These Input Command Responses are not functional and will always consist of zero valued data.

Note 8 - These Status commands sent by the host are accepted by the treadmill, but not implemented functionally. For instance, a command to query the current calories will be accepted, but a value of zero will always be returned.

Note 9 - These Status Command Responses are not functional and will always consist of zero valued data.

Note 10 - The emergency stop switch will remove power from the treadmill control board to guarantee a stop condition. When this occurs and the emergency stop button is subsequently released, the control will be in the same state as when the unit is powered up using the main power switch. Therefore, it is necessary in either power-up state to guard against inadvertent restarts if the host doesn't recognize the situation and is continuously sending out belt start commands. The method used to guard against this situation is to reject any start command received within 3 seconds of powering up and finding the zero-elevation position. If a start command is ejected, all further start commands will also be rejected until the unit is reset or a stop command is received or communication ceases for 20 seconds.

## Self-test MODE

On power-up, the UPS sends out a special test character ‘T’ and checks to see if it is returned. This is a check for a shorting jumper across the transmit and receive lines of the RS-232 serial port. Note that it is not possible to enter self-test using the USB port. If the RS-232 lines are determined to be shorted, the UPS enters the Self-test Mode. During the Self-test Mode, 14 stages of speed and elevation set points are used to exercise the inputs and outputs. Upon completion of each new set point, another character is sent out and the process is repeated to advance to the next stage. In this way, the shorting jumper can be removed at any point to stop the staging process. The following table shows the sequence of self-test stages:

STAGE	INCLINE	SPEED (MPH)
1	5%	0.0
2	10%	0.0
3	15%	0.0
4	20%	0.0
5	20%	1.0
6	20%	2.5
7	20%	5.0
8	20%	7.5
9	20%	10.0
10	15%	7.5
11	10%	5.0
12	5%	2.5
13	0%	1.0
14	0%	0.0

## CALIBRATION

Both a speed and an elevation calibration method are provided in the UPS software. The elevation calibration requires manually adjusting the deck to find the sensor counts for 7 fixed elevation positions and is not recommended for field adjustment without special treadmill interface software. During speed calibration, the speed reference output is swept across its range and speed measurements are made at 15 points. This function is also only available through the use of special treadmill interface software.

## DIP SWITCH SETTINGS

A dip switch is located on the UPS at location SW2. An arrow indicates the “ON” position, and each switch is numbered 1-4. Currently, only two of the switches are read by the UPS, and both are only checked on power-up so changing the switches while the system is running will not have an effect until power is cycled. Switch 1 is the Unit selection switch. When in the “OFF” position, units are set to English, and in the “ON” position, units are set to metric. Switch 2 is a long timeout option. When Switch 2 is in the “OFF” position, a communication disconnect stop timeout is 2.5 seconds, but when switch 2 is in the “ON” position, the communication disconnect stop timeout is extended to 4 seconds. Position Dip Switch 3 (Firmware Version 1.43 & later FGLF0495 Smart Power Supply): When in the “OFF” position for Trackmaster Interface Protocol, in the “ON” position New Customer Interface Protocol. Dip Switch 4 in the “OFF” position for factory use only.

Additional dip switch on UPS (Firmware Version 1.1812 and later FGLF-4953-03 Smart Power Supply). This configuration has 1-6 number switches, position 1 thru 4 are same as (FGLF0495-1 Smart Power

Supply). When retrieving system flash log file switch configuration 1,2,3,4, and 6 are in the “OFF position and switch 5 is in the “ON” position. Refer to “Log File Retrieval” under Chapter-6 Operating Instructions.

## ELECTRICAL INPUTS

- A) Instrument Power: 230VAC or 120VAC supplied through (2) 1/4 Amp breakers in parallel for control board power. 230VAC or 120VAC supplied through (2) 3 Amp breakers in parallel for elevation motor power.
- B) Elevation Sensor Input: A two wire interface for detecting the presence of a closed micro-switch on the elevation motor.
- C) Speed Sensor Input: A three wire interface for detecting the state of a magnetic reed switch on the motor shaft.
- D) Serial Port Input: An electrically isolated RS-232 serial port from the host controller.
- E) USB Port Input: An electrically isolated USB port from the host controller.
- F) Motor Controller Fault: Fault signal supplied from motor controller.
- G) Voltage Selection Switch: The onboard input voltage selection switch allows the unit to be used at 115VAC or 230VAC.
- H) Emergency Stop Switch: A normally closed switch input used to switch power to the UPS control must be rated at 24 Volts DC and 3 Amps continuous duty.

## ELECTRICAL OUTPUTS

- A) Elevation Motor: AC Common is permanently provided to the elevation motor. In addition, the 120/230VAC hot input for motor elevation power is switched through a 10 Amp relay to either the up or down input to the elevation motor.
- B) Motor Controller Drive Enable Output: An optically isolated output is provided to switch on the start input circuit for the belt drive. This output is to provide no more than 2mA.
- C) Speed Output: A PWM signal for speed is provided to the motor controller. The signal is toggled between the motor controller’s signal reference voltages (5Vdc). The maximum current for this output is 2mA and the maximum voltage is 15Vdc.
- D) Serial Port Output: An electrically isolated RS-232 level (not to exceed +/- 10VDC) is provided to the host controller.
- E) USB Port Output: An electrically isolated USB port to the host controller not to exceed 5V or 100mA.

## ELECTRICAL CONNECTIONS

- A) Input Power Header: An Amp - 641968-1 4-pin MATE & LOCK header is provided for instrument power.
- B) Elevation Output Header: An Amp 641968-1 3-pin MATE & LOCK headers is provided for output power to the elevation motor.
- C) Elevation Input Header: A 3-pin 0.156" pitch header is provided for the input from the elevation sensor.
- D) Speed Input Header: A 2-pin 0.156" pitch header is provided for the input from the magnetic reed switch speed sensor.
- E) Motor Controller Interface: A 10-pin 0.1" pitch header is provided for interfacing to the motor controller.
- F) RS-232 Interface: A DB9 Connector 9-pin PC/AT Style is provided for interfacing with the host controller.
- F) USB Interface: A Mini-B right angle USB Connector is provided for interfacing with the host controller.
- H) Emergency Stop Switch: Two 0.187" quick connect blade terminals are provided for an emergency stop switch input.

## PHYSICAL REQUIREMENTS AND RESTRICTIONS

- A) The printed circuit board should be a rigid 1/16" thick, FR4, SMOBC circuit board with 2 ounce copper.
- B) Galvanic isolation between the AC power circuits and the low voltage electronic circuits should be guaranteed.
- C) Outer Dimensions: 6"T x 9"W x 2.5"D (max).
- D) Mounting position: The board shall be capable of being mounted with the PCB either parallel or perpendicular to the bottom pan of the treadmill.
- E) Environment: 0 - 70 deg. C ambient temperature.
- F) High level vibrations from adjacent equipment may be present.
- G) After installation into the treadmill, expect the board to experience moderate shock impulses during shipment.

# UNIVERSAL POWER SUPPLY BOARD 3.1 Edition (FGLF0495-

1)

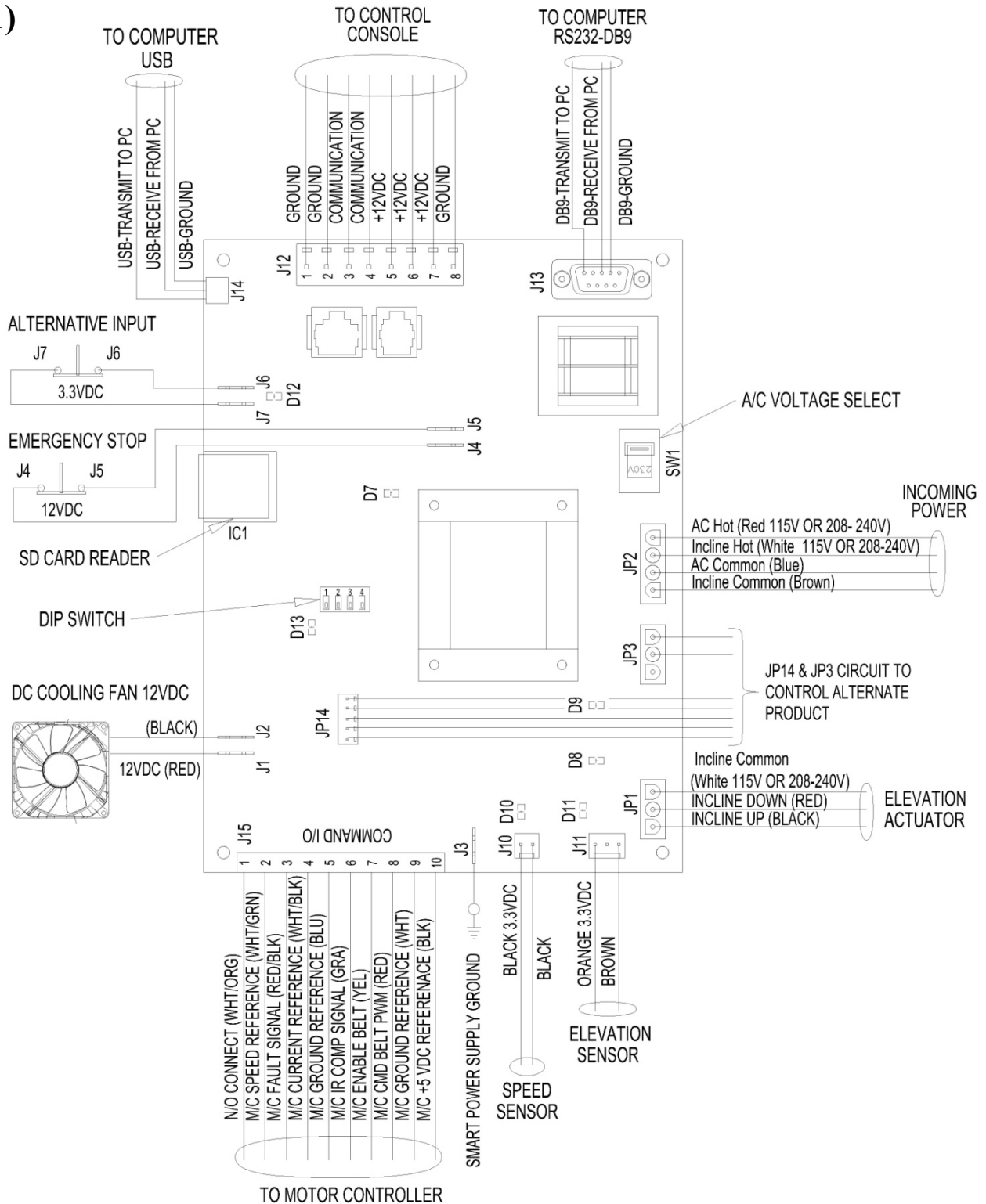



# UNIVERSAL POWER SUPPLY BOARD 4<sup>th</sup> Edition (FGLF0495-3)

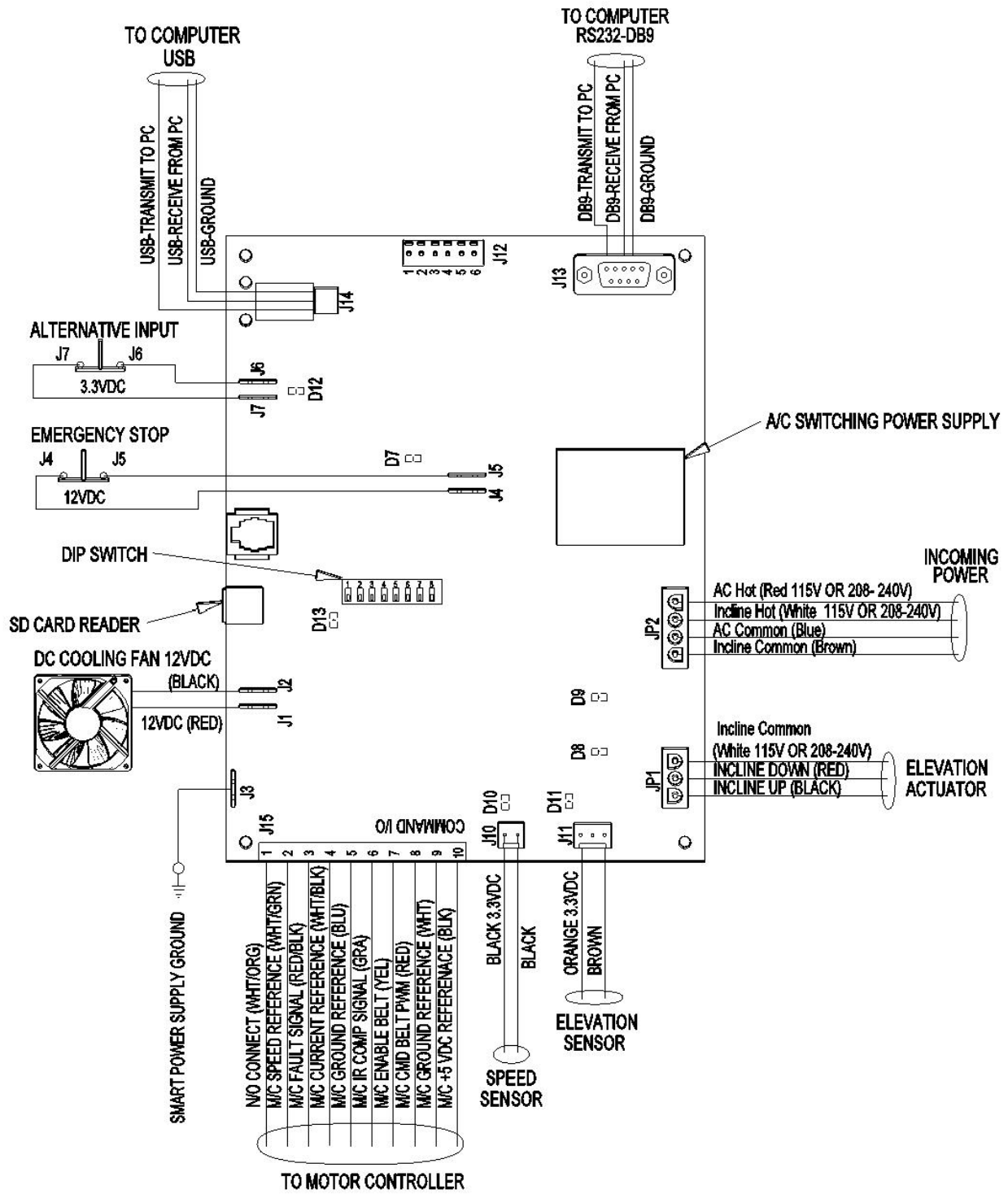

9

# Troubleshooting

## Incoming Power 110-240VAC Flow Chart 1A

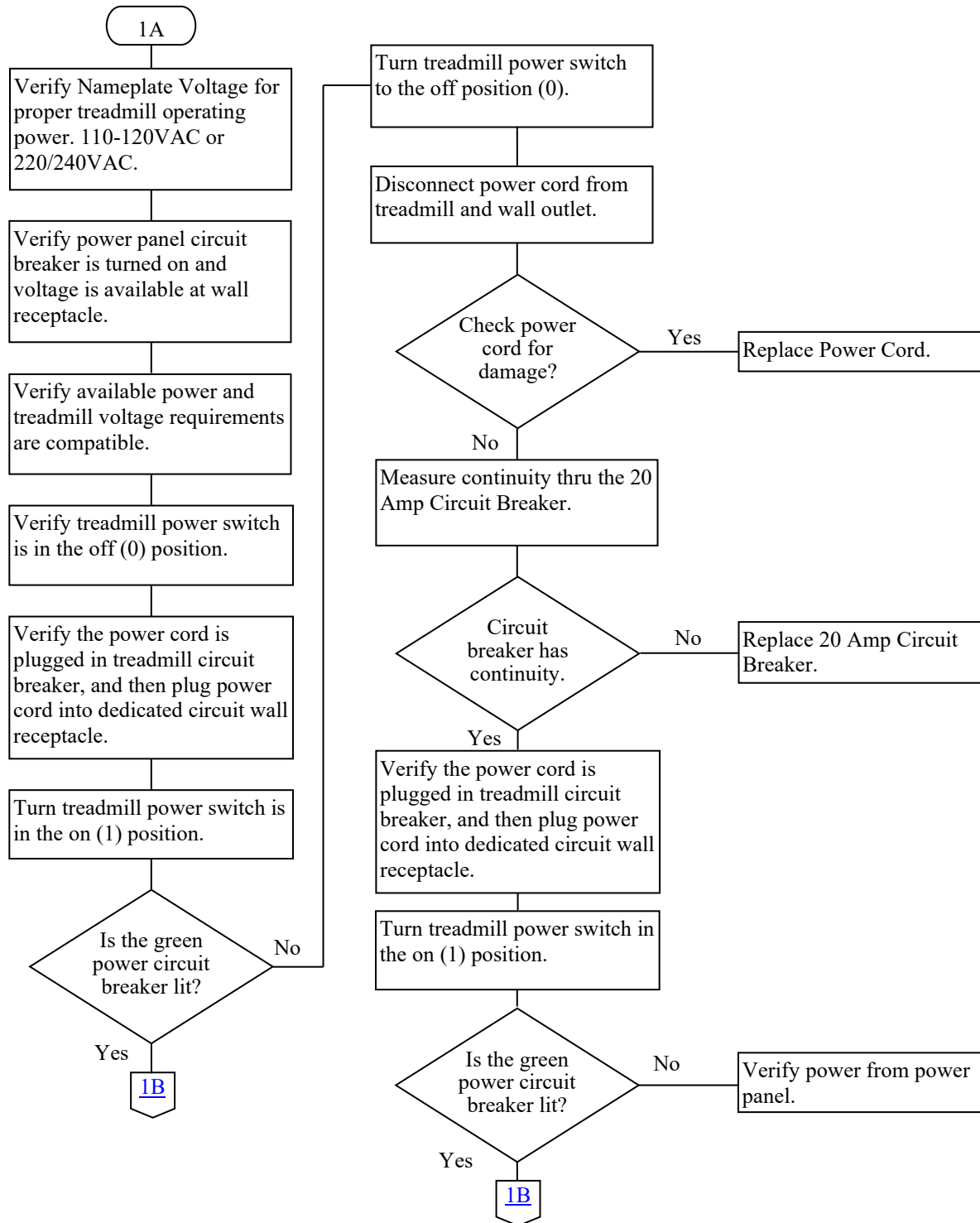

# Incoming Power Inline Filter Flow Chart 1B

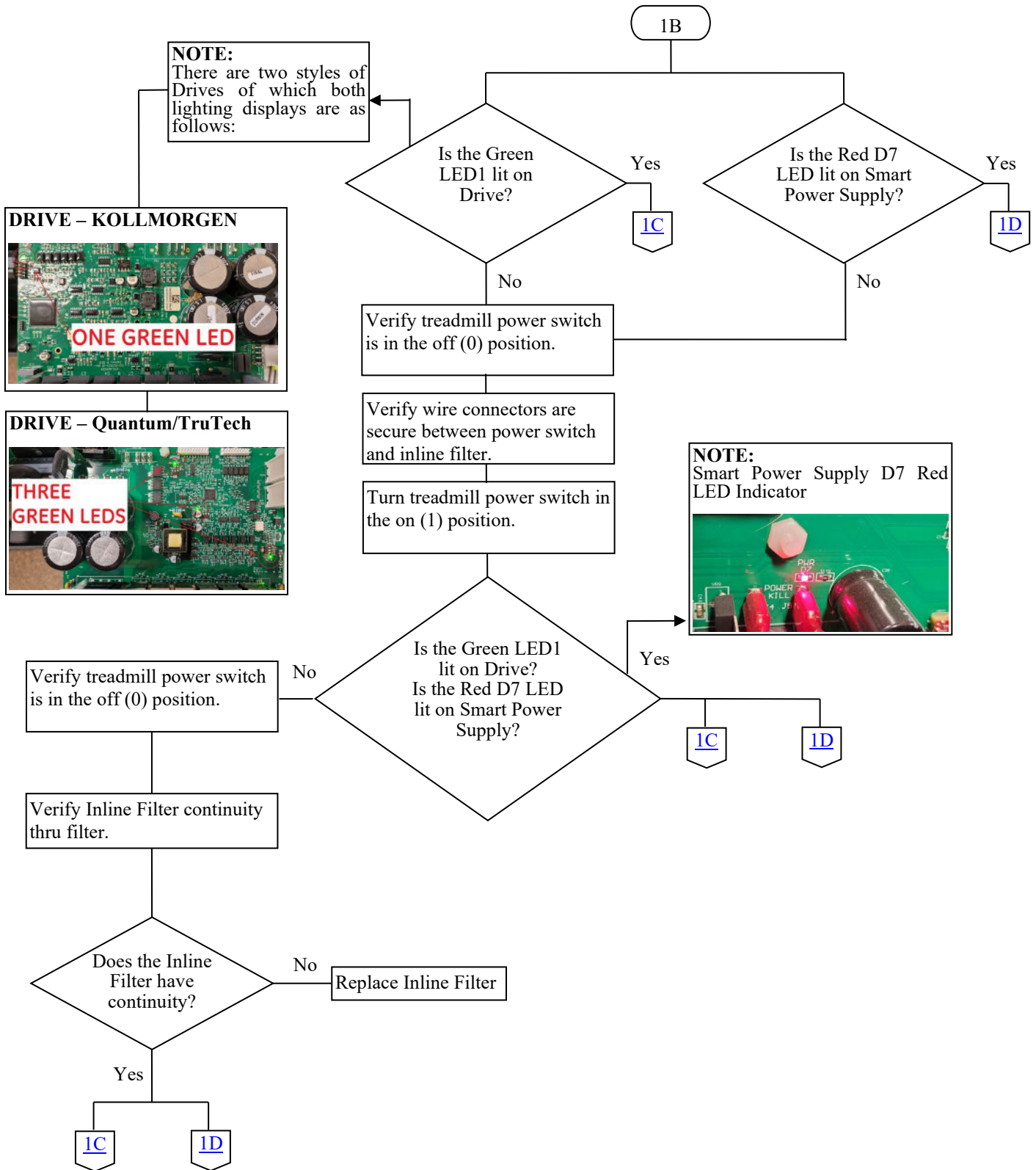

# Incoming Power Drive Flow Chart 1C

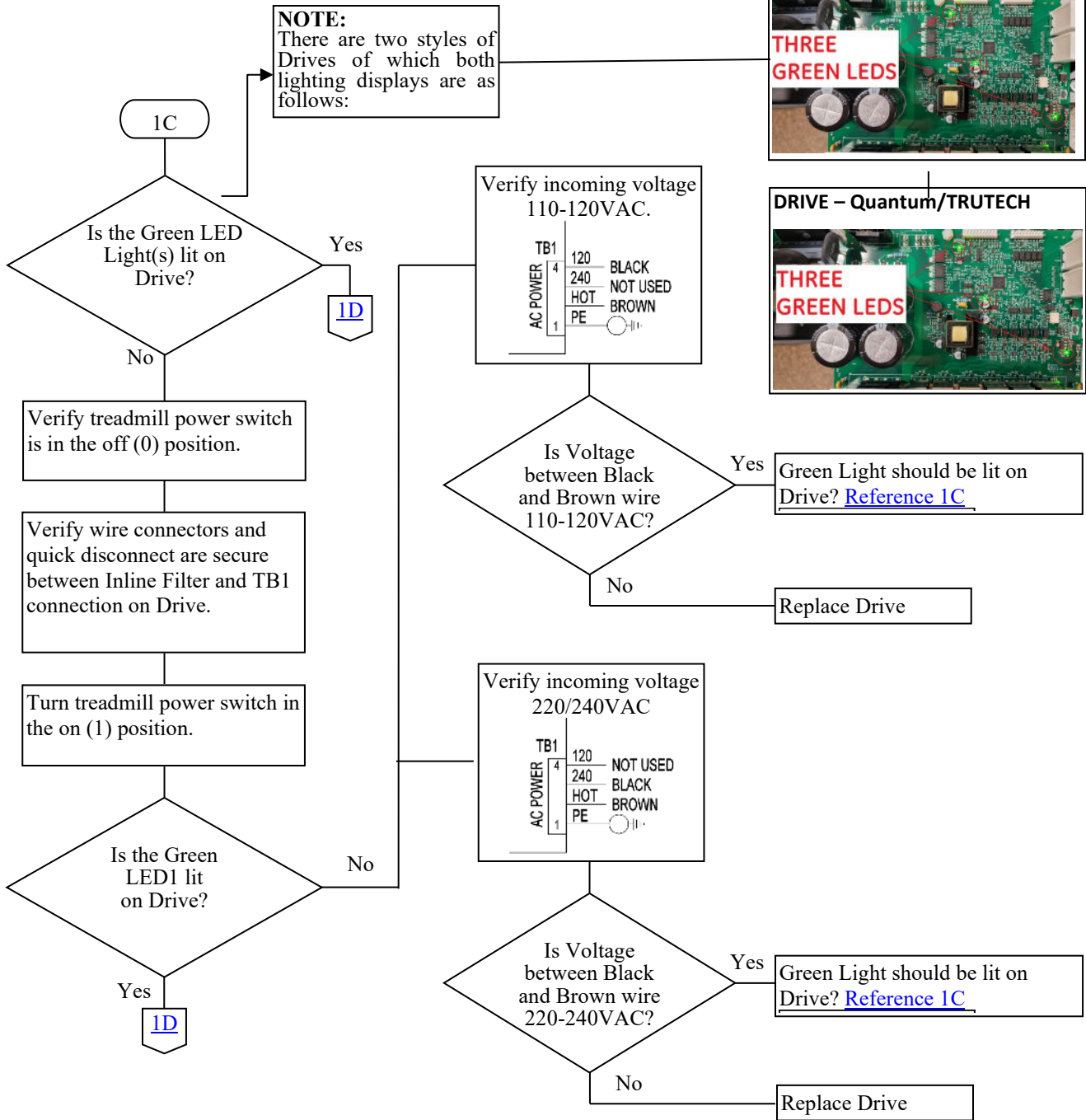

## Smart Power Supply Incoming Power 110-240VAC Flow Chart 1D

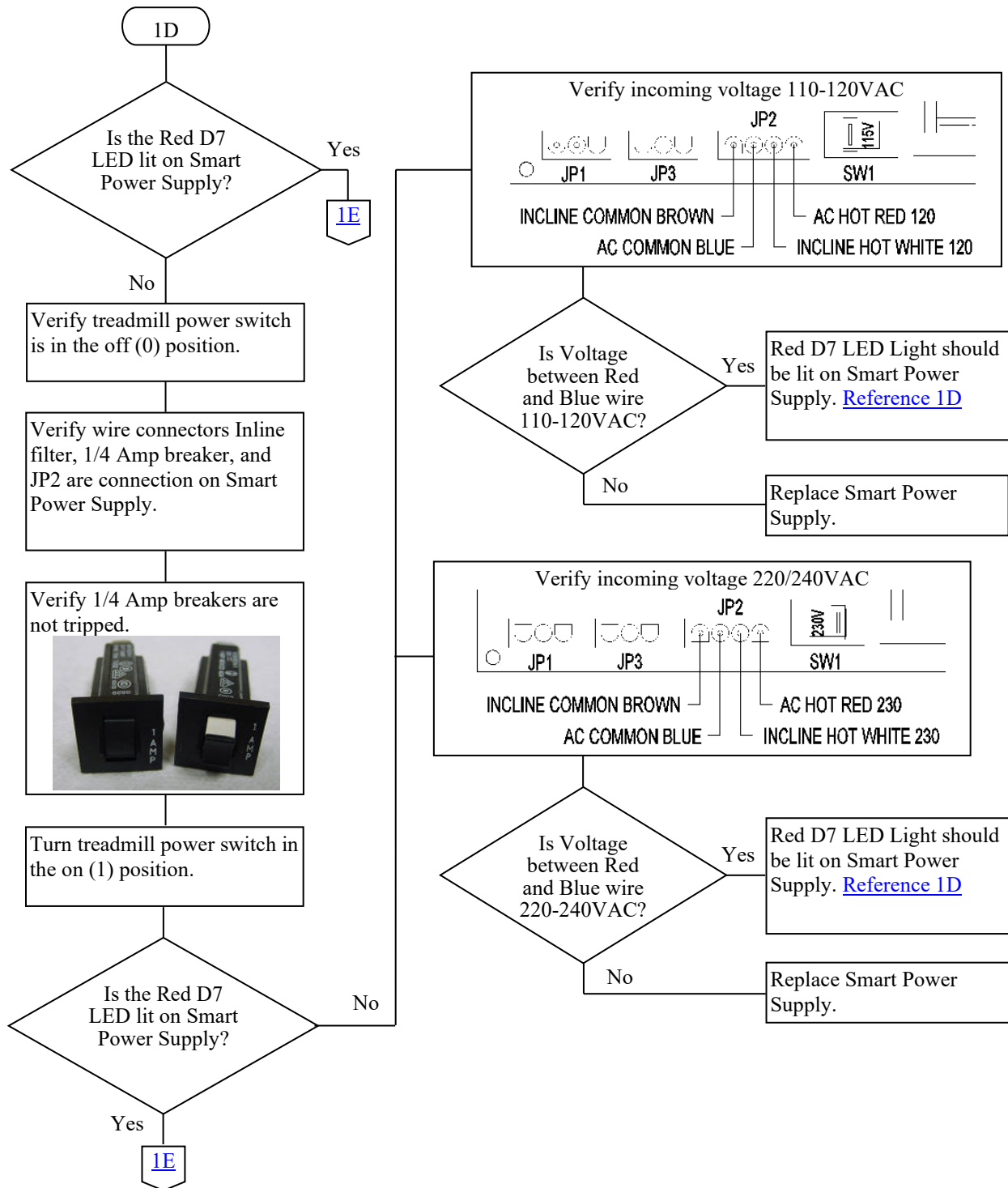

## Emergency Stop Flow Chart 1E

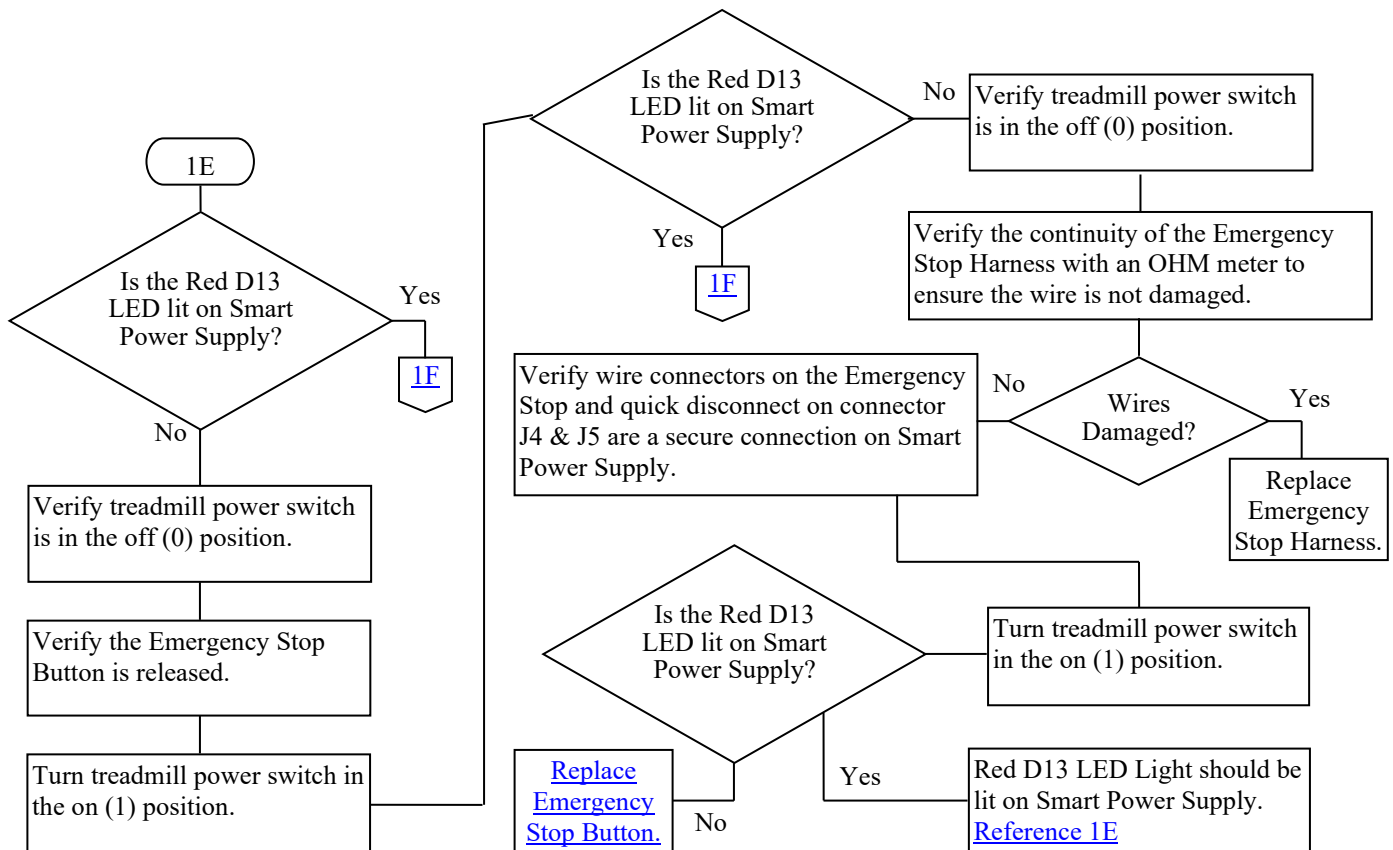

# Patient Safety Tether Flow Chart 1F

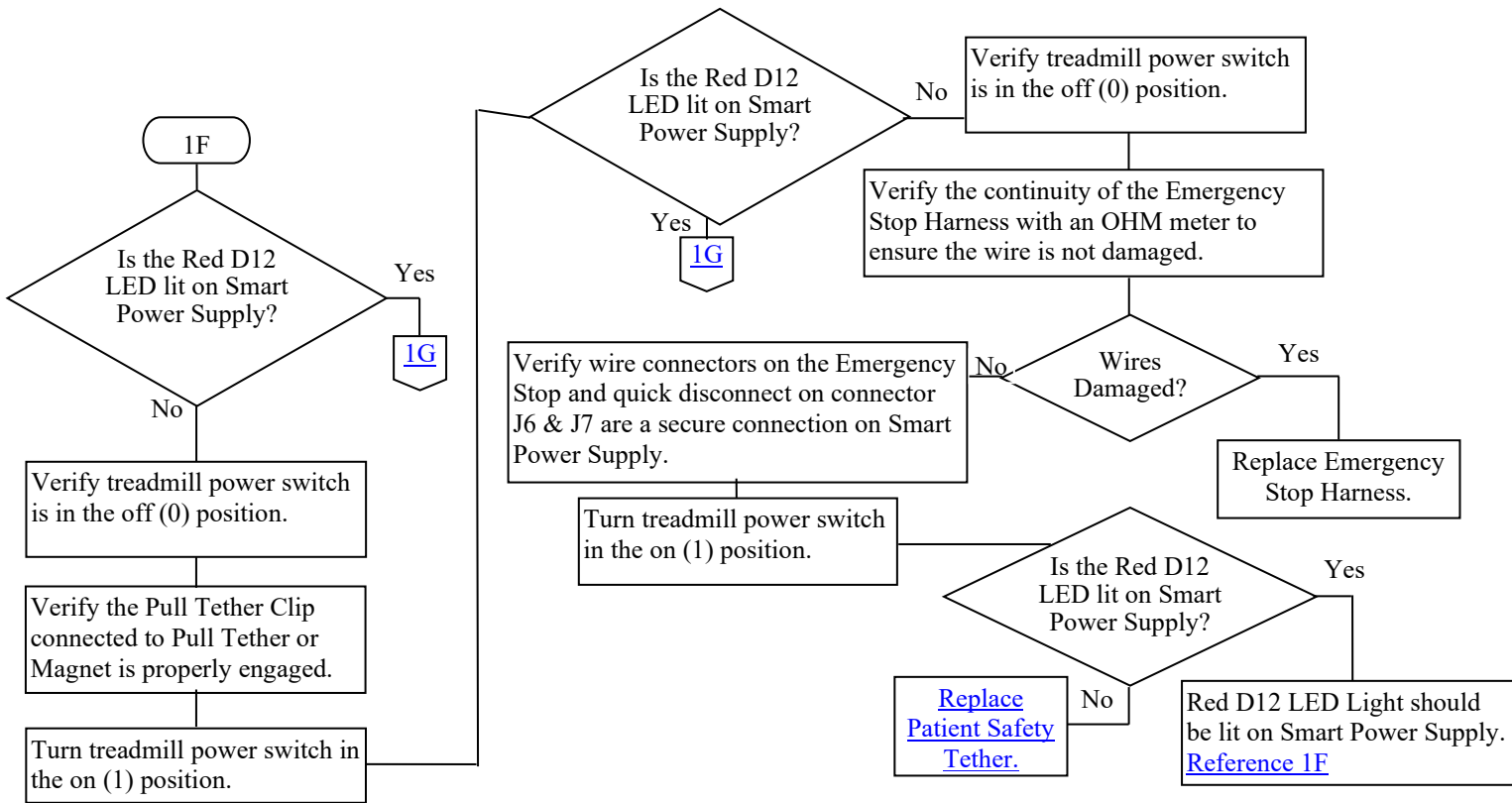

# Communication RS232 Flow Chart 1G

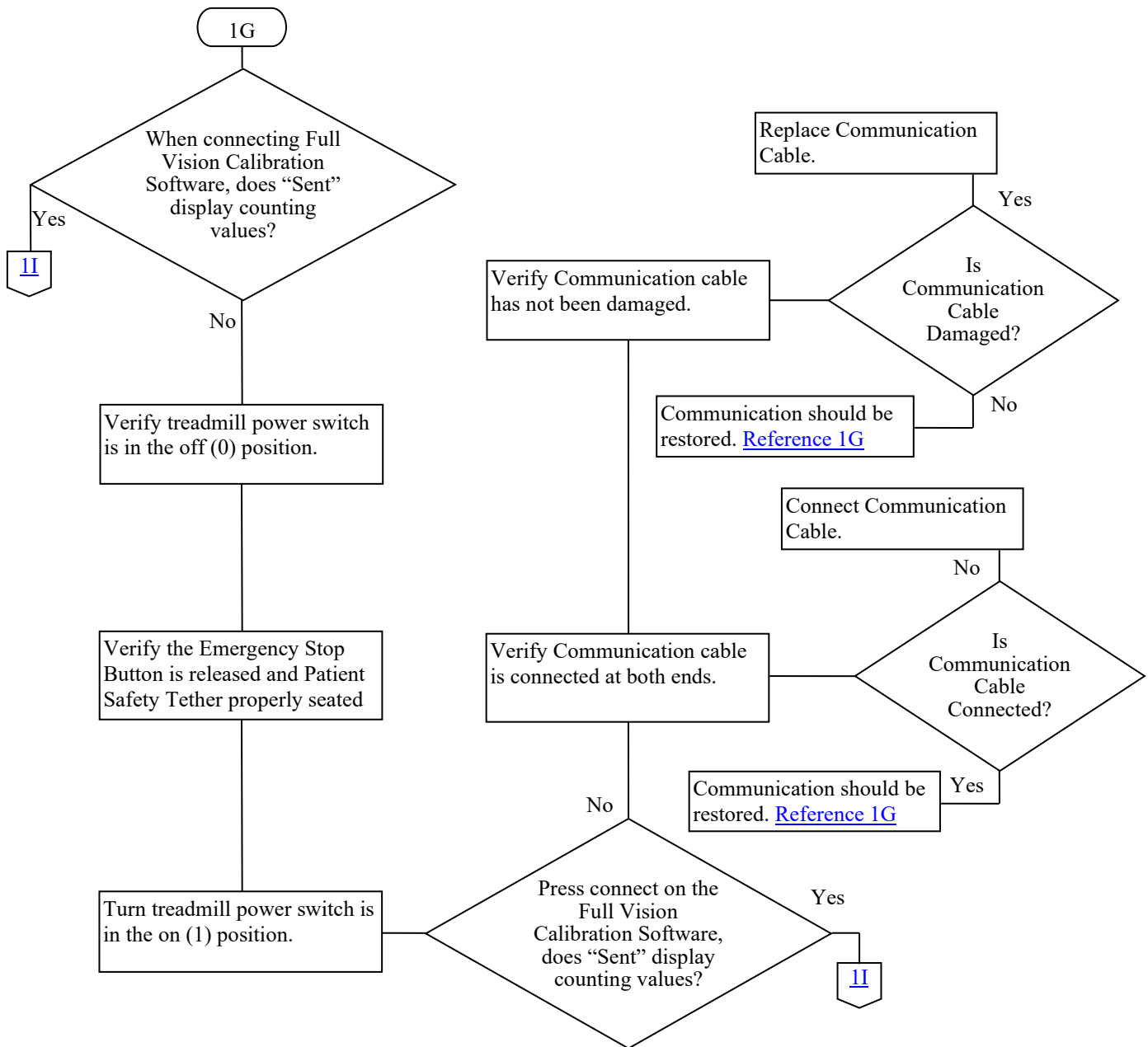

### Communication RS232 Flow Chart 1H

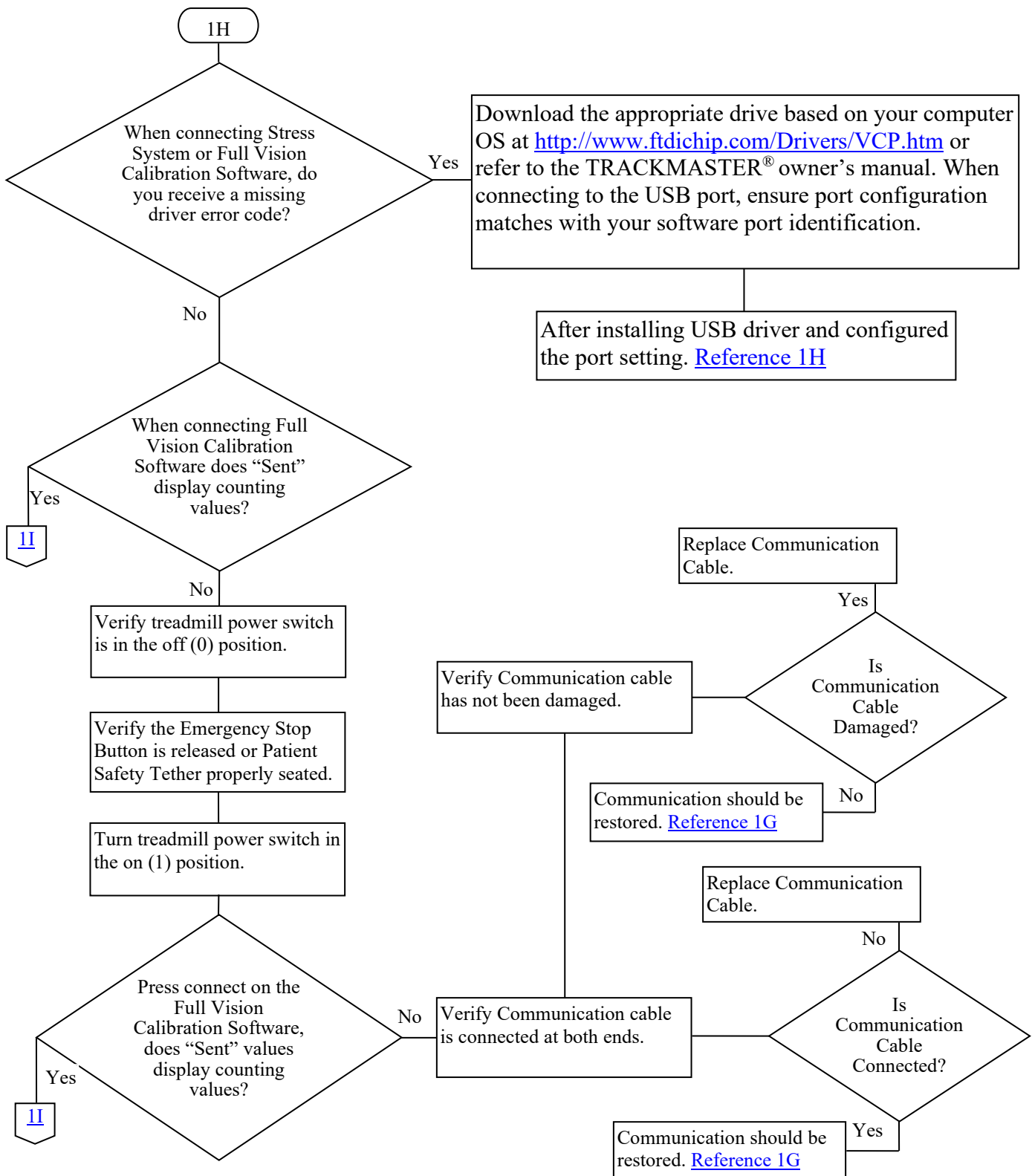

## Smart Power Supply Error Code Identification Flow Chart 1I

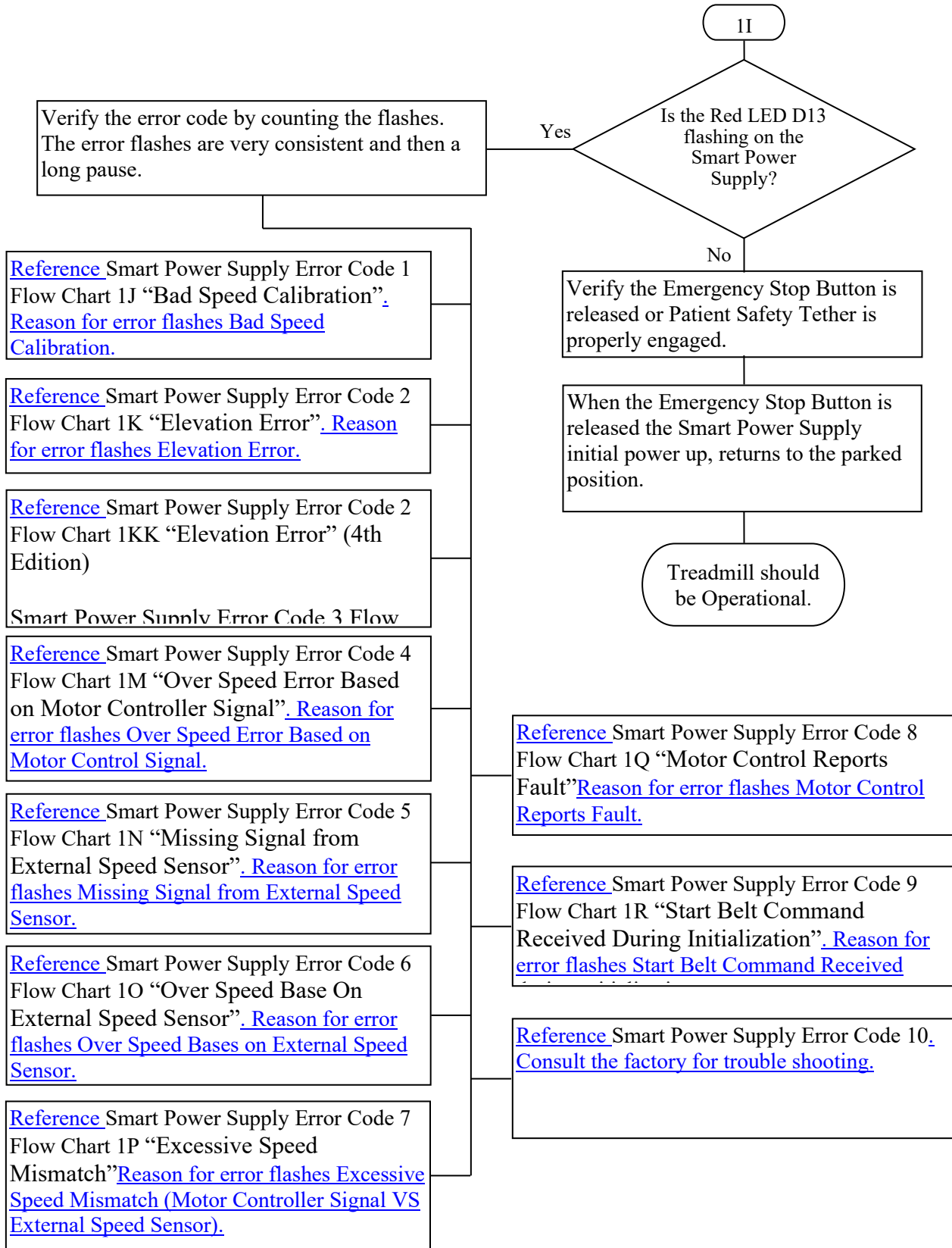

# Smart Power Supply Error Code 1 Flow Chart 1J “Bad Speed Calibration”

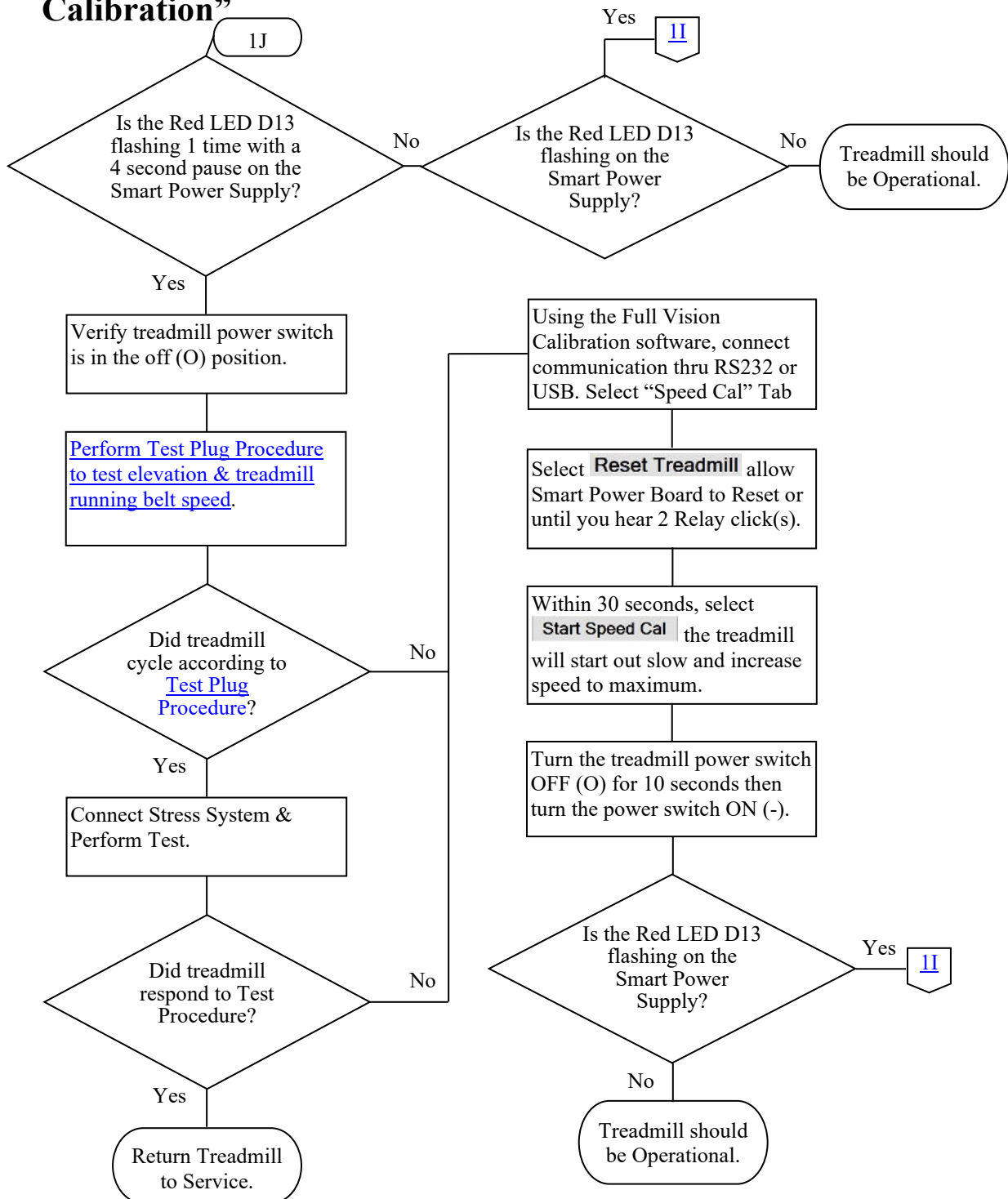

# Smart Power Supply Error Code 2 Flow Chart 1K “Elevation Error” (3<sup>rd</sup> Edition)

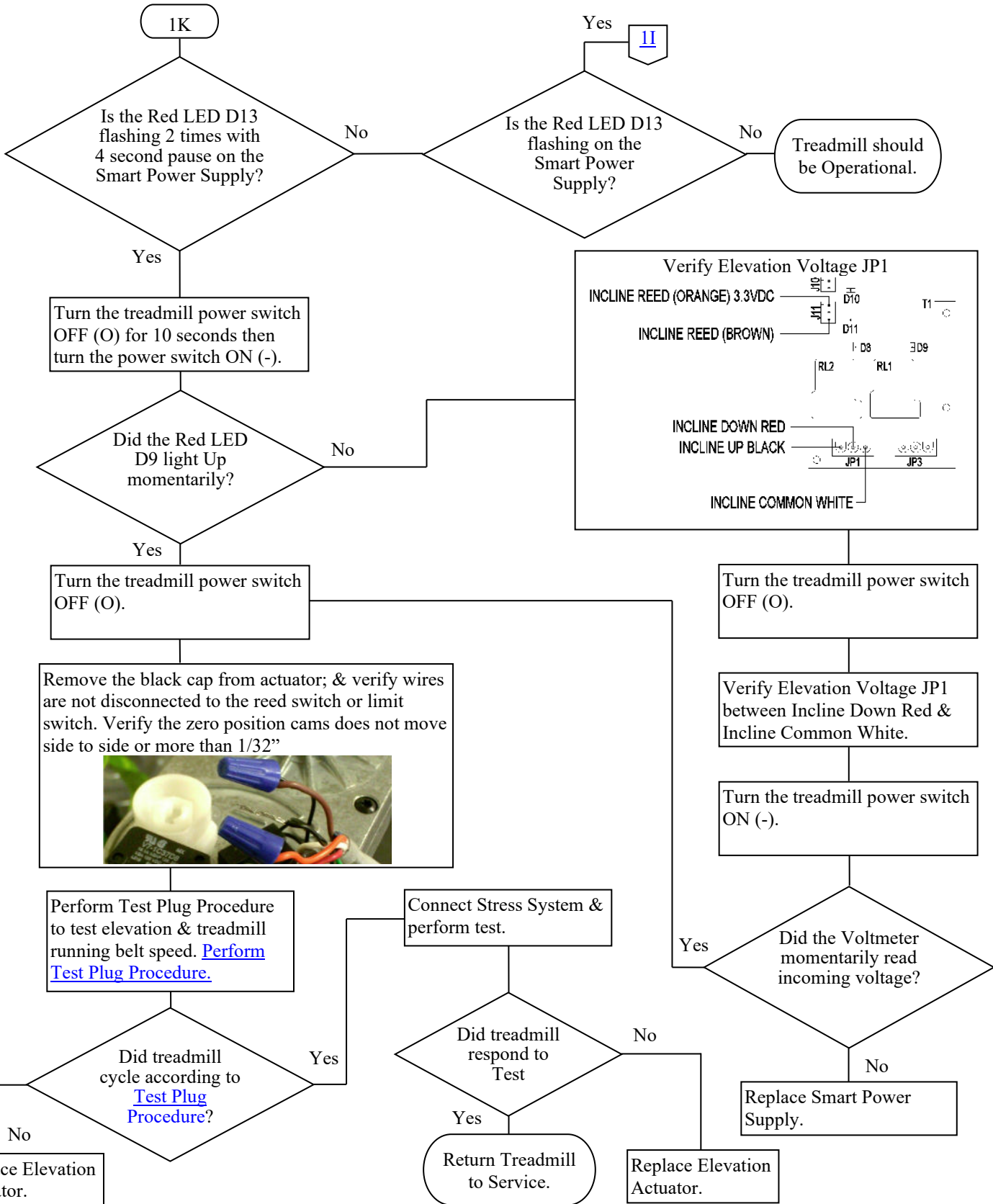



# Smart Power Supply Error Code 3 Flow Chart 1L “Missing Speed Signal From Motor Controller”

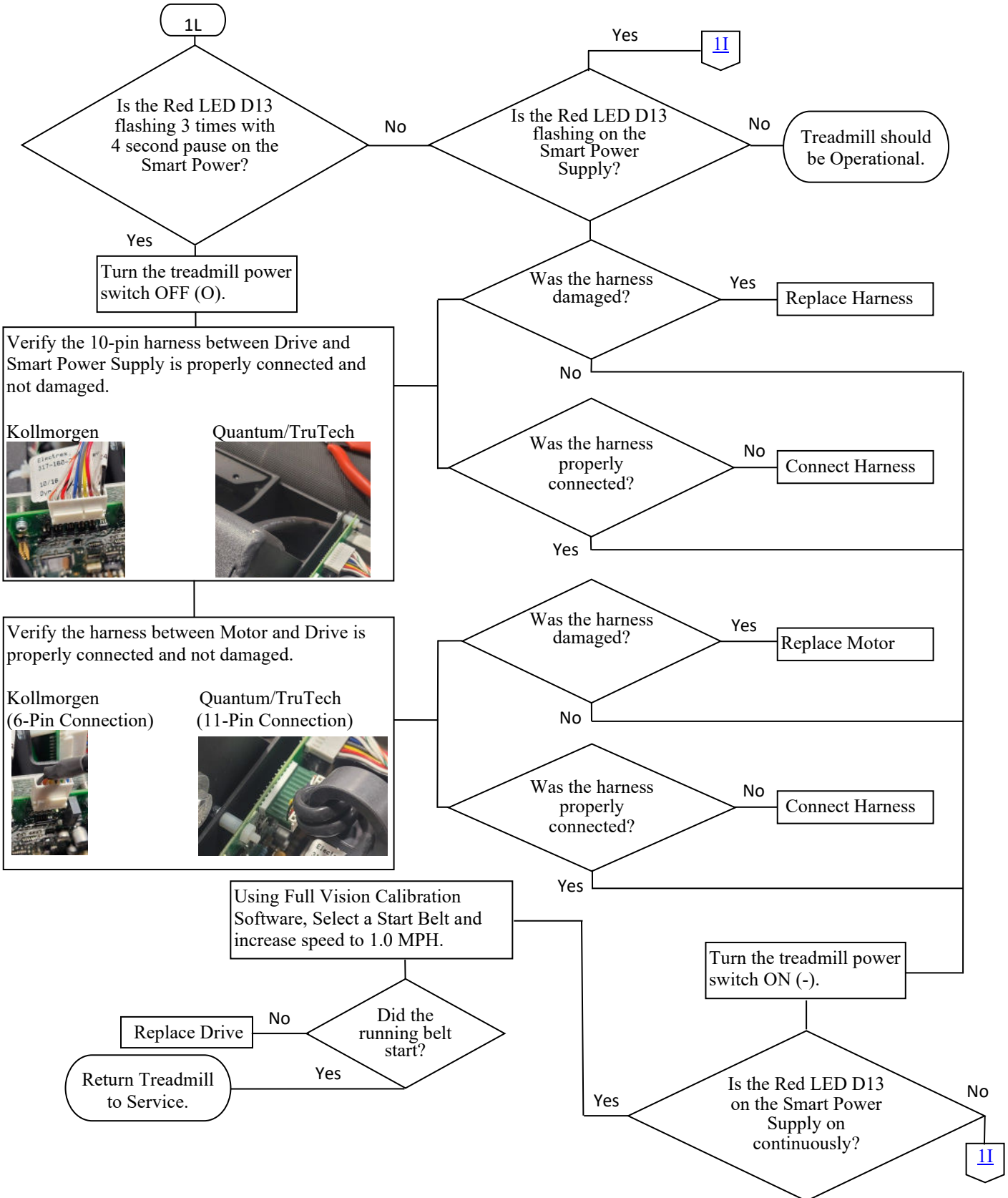

## Smart Power Supply Error Code 4 Flow Chart 1M “Over Speed Error Based on Motor Controller Signal”

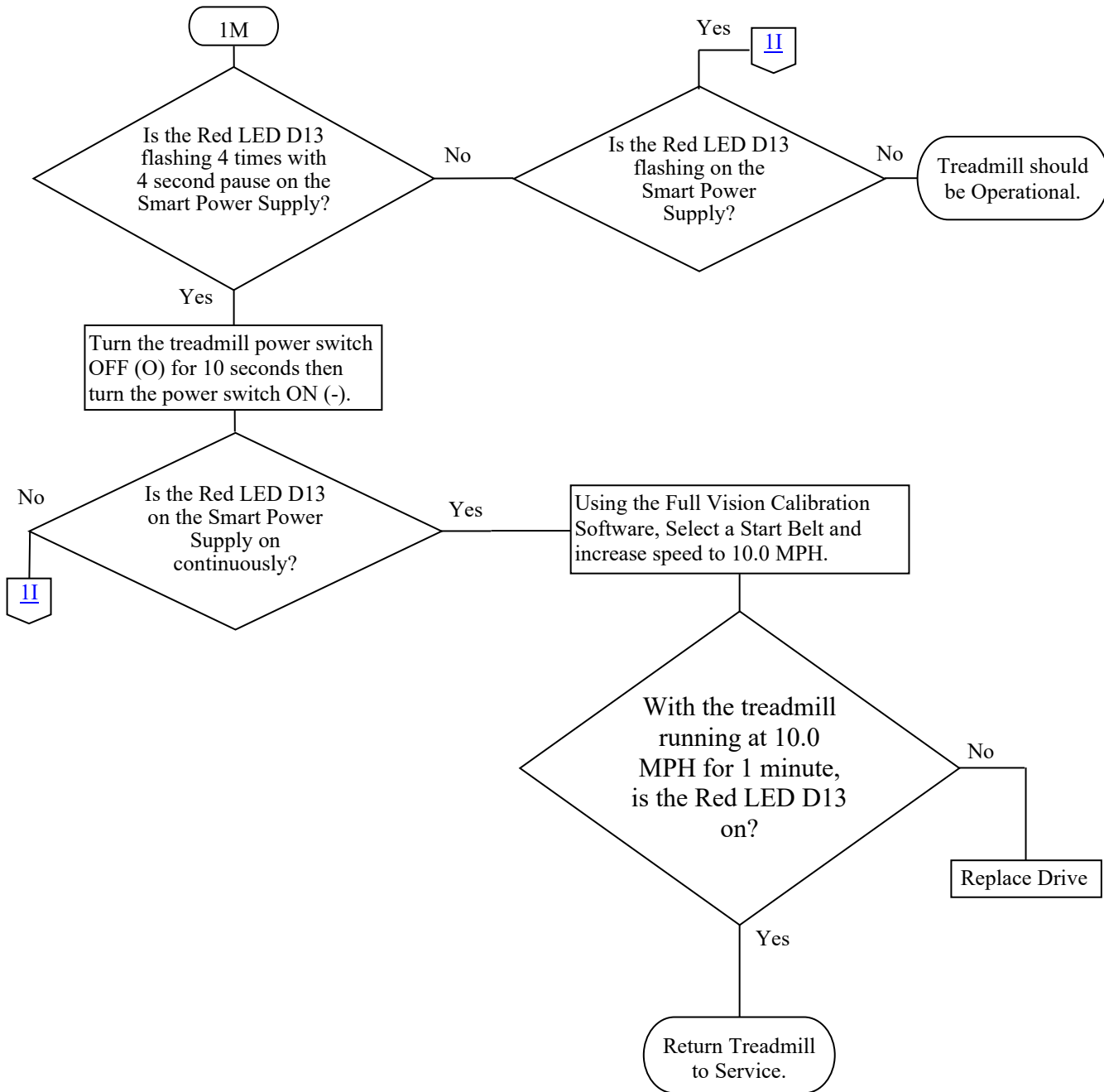

# Smart Power Supply Error Code 5 Flow Chart 1N “Missing Signal from External Speed Sensor”

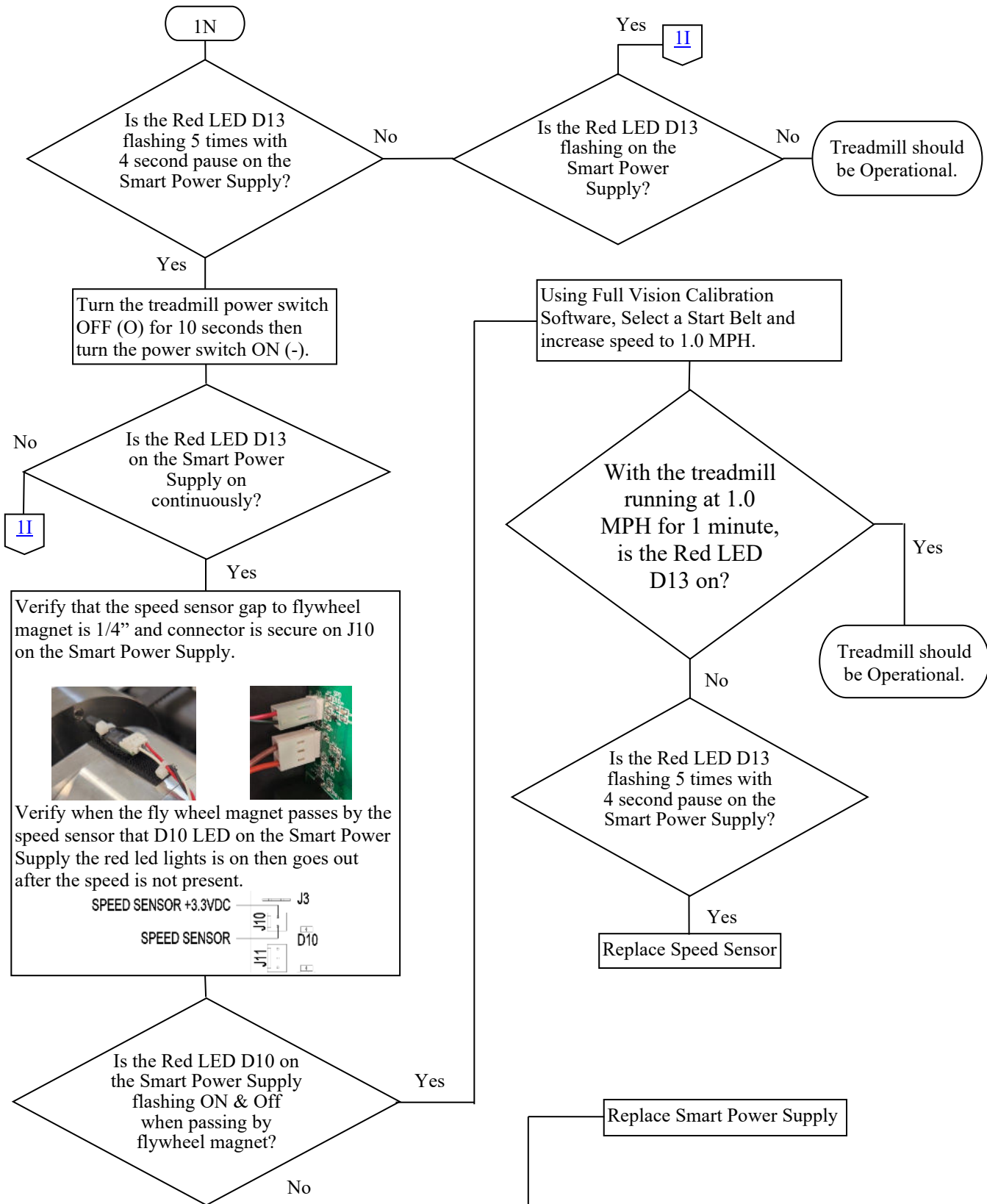

# Smart Power Supply Error Code 6 Flow Chart 10 “Over Speed Base On External Speed Sensor”

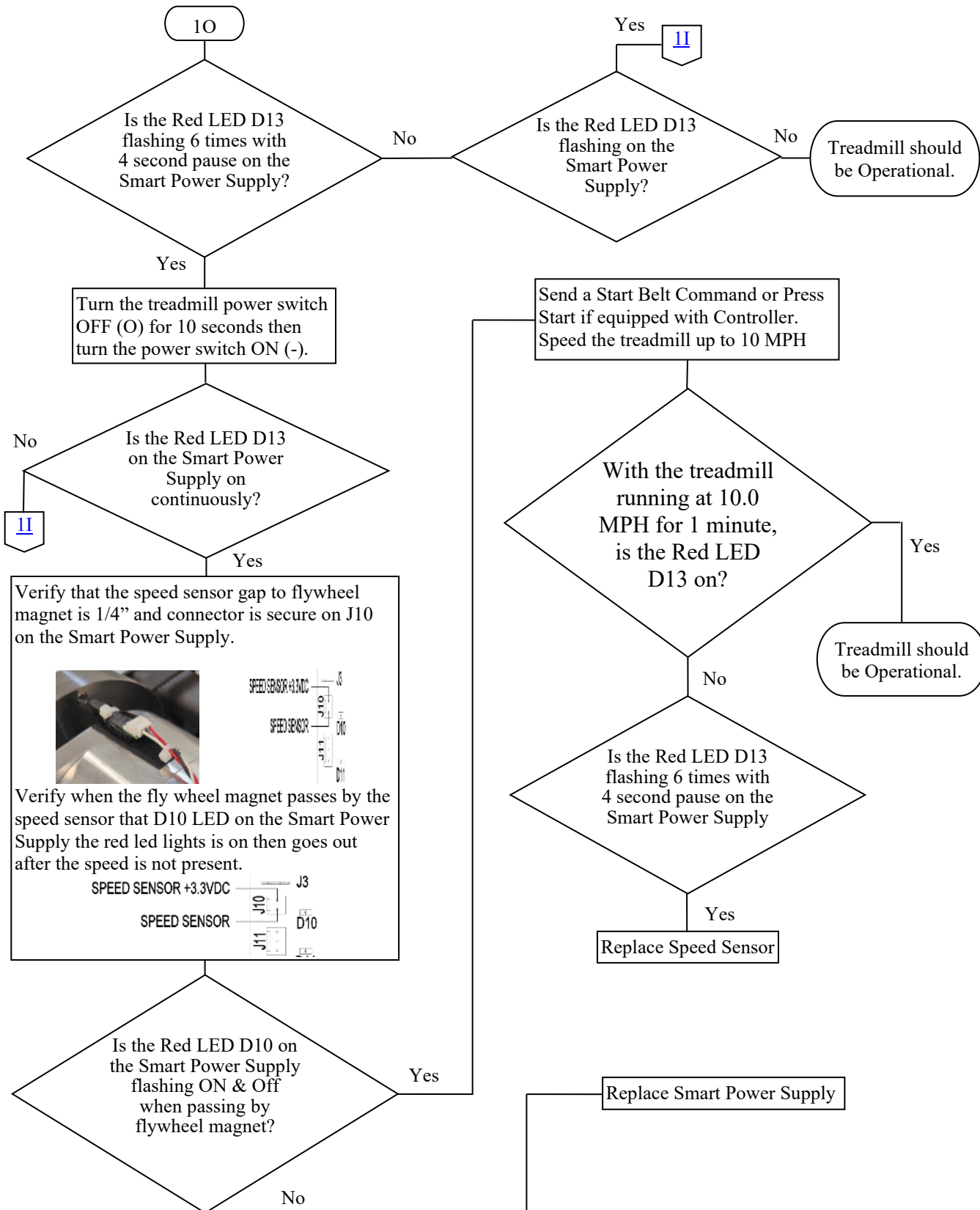

# Smart Power Supply Error Code 7 Flow Chart 1P “Excessive Speed Mismatch”

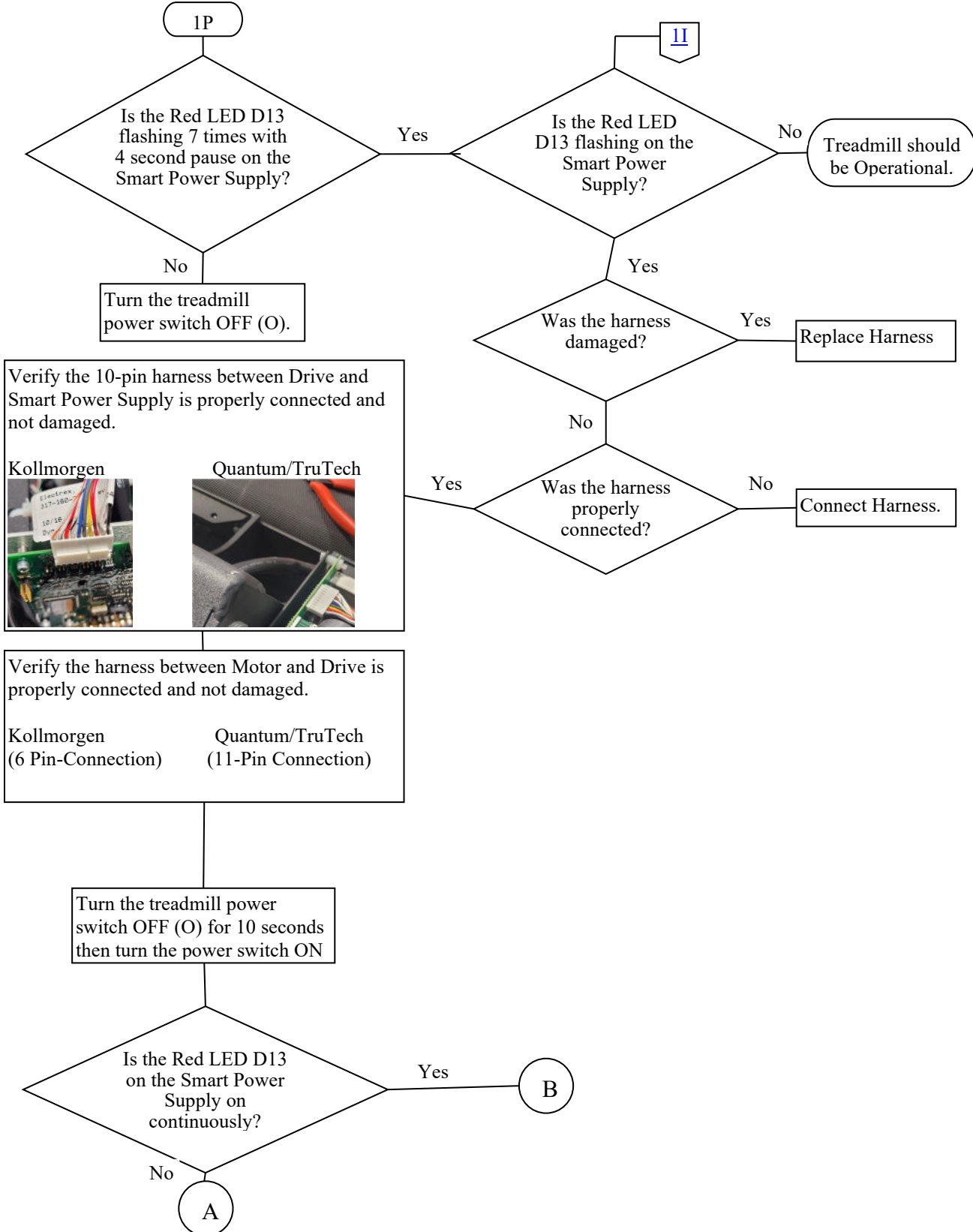

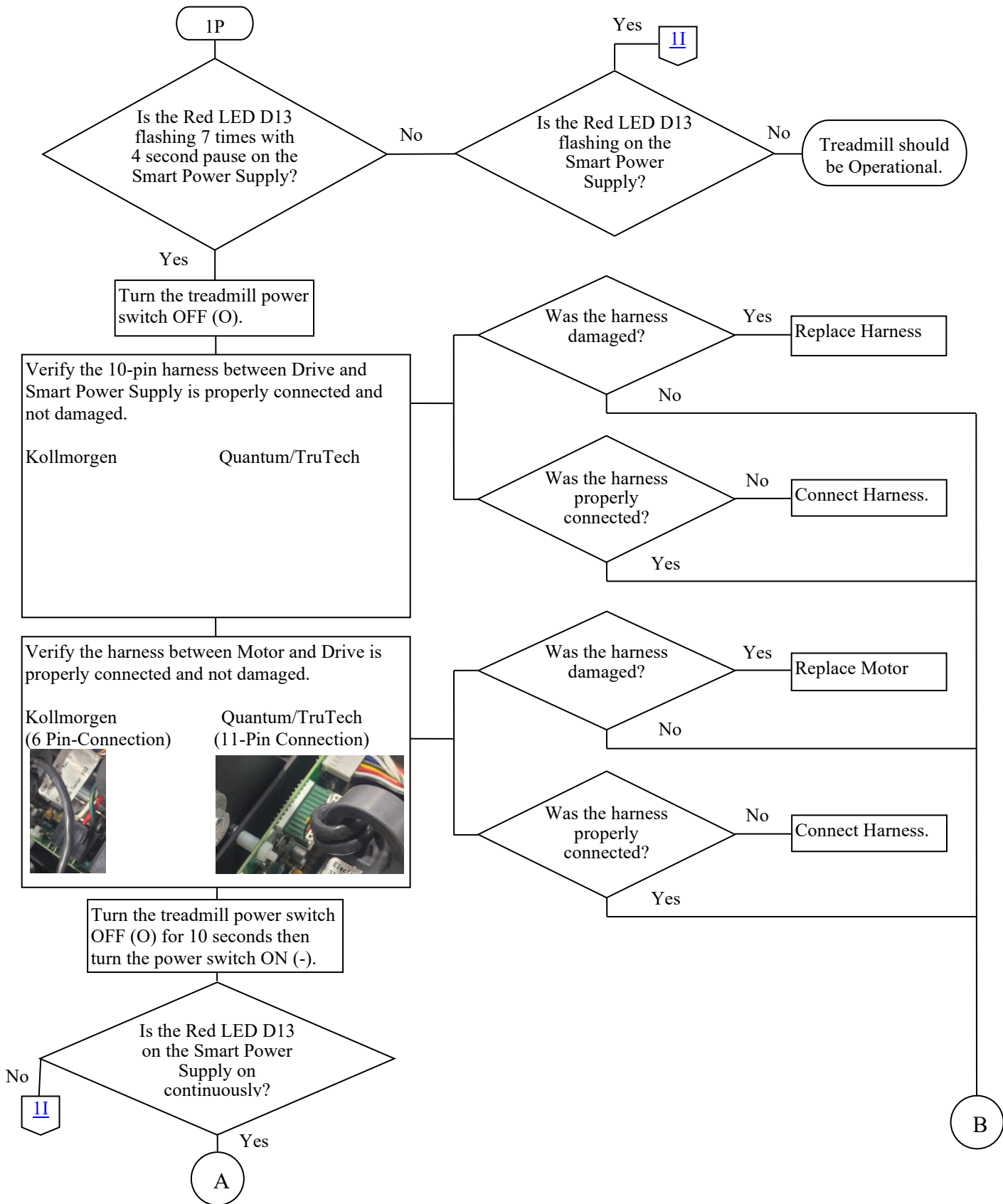

# Smart Power Supply Error Code 7 Flow Chart 1P “Excessive Speed Mismatch” Continued

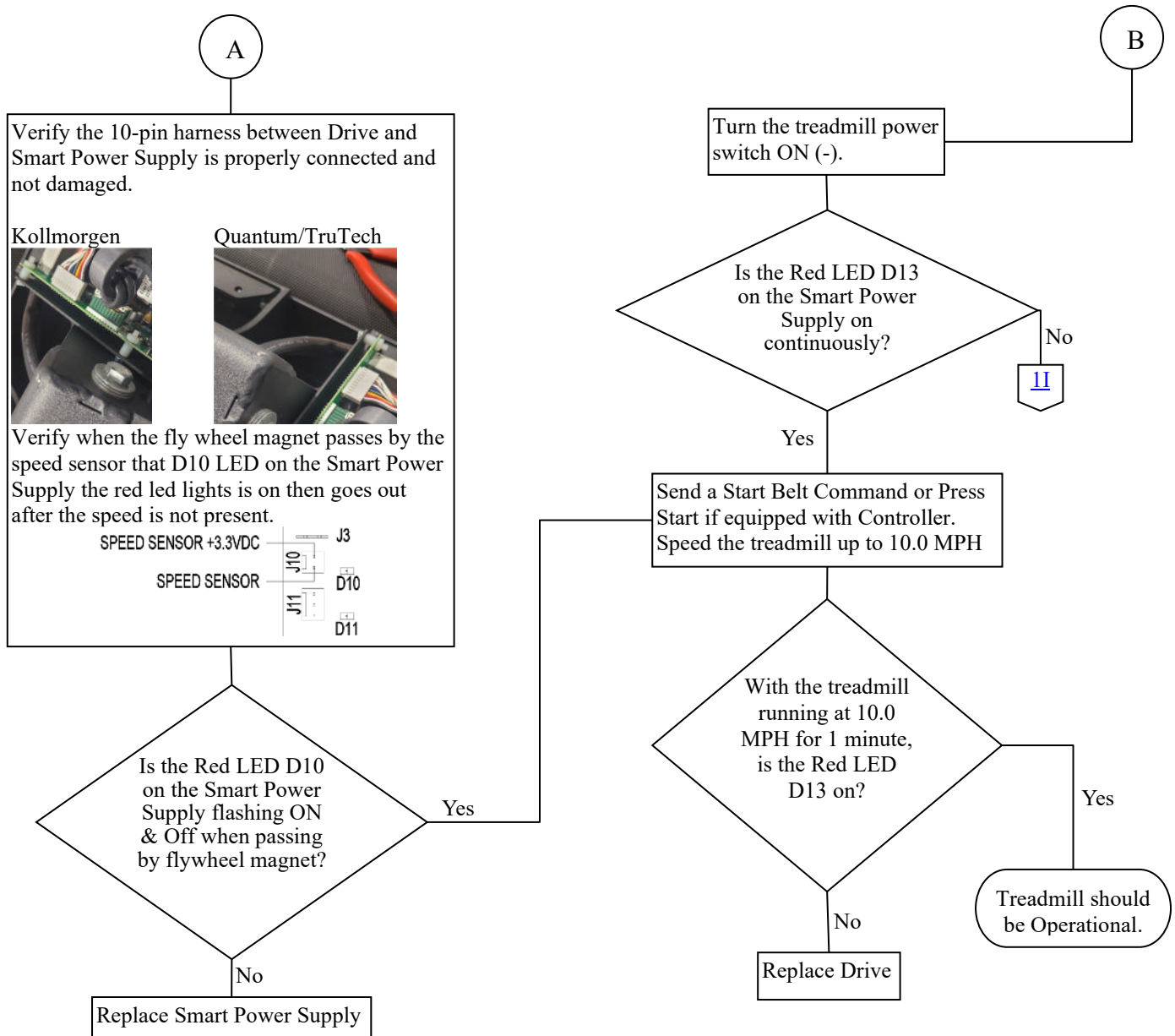

# Smart Power Supply Error Code 8 Flow Chart 1Q “Motor Control Reports Fault”

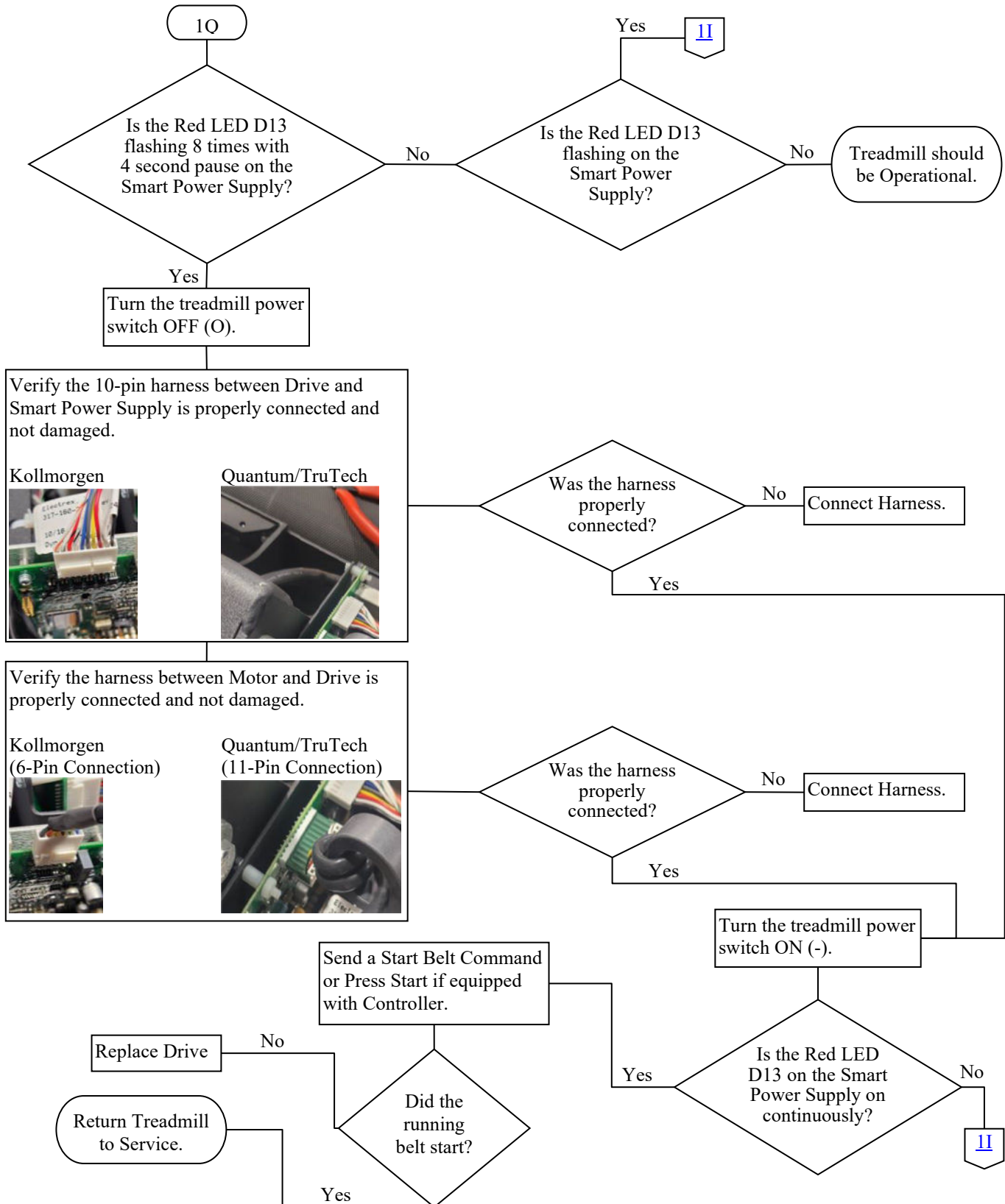

# Smart Power Supply Error Code 9 Flow Chart 1R “Start Belt Command Received During Initialization”

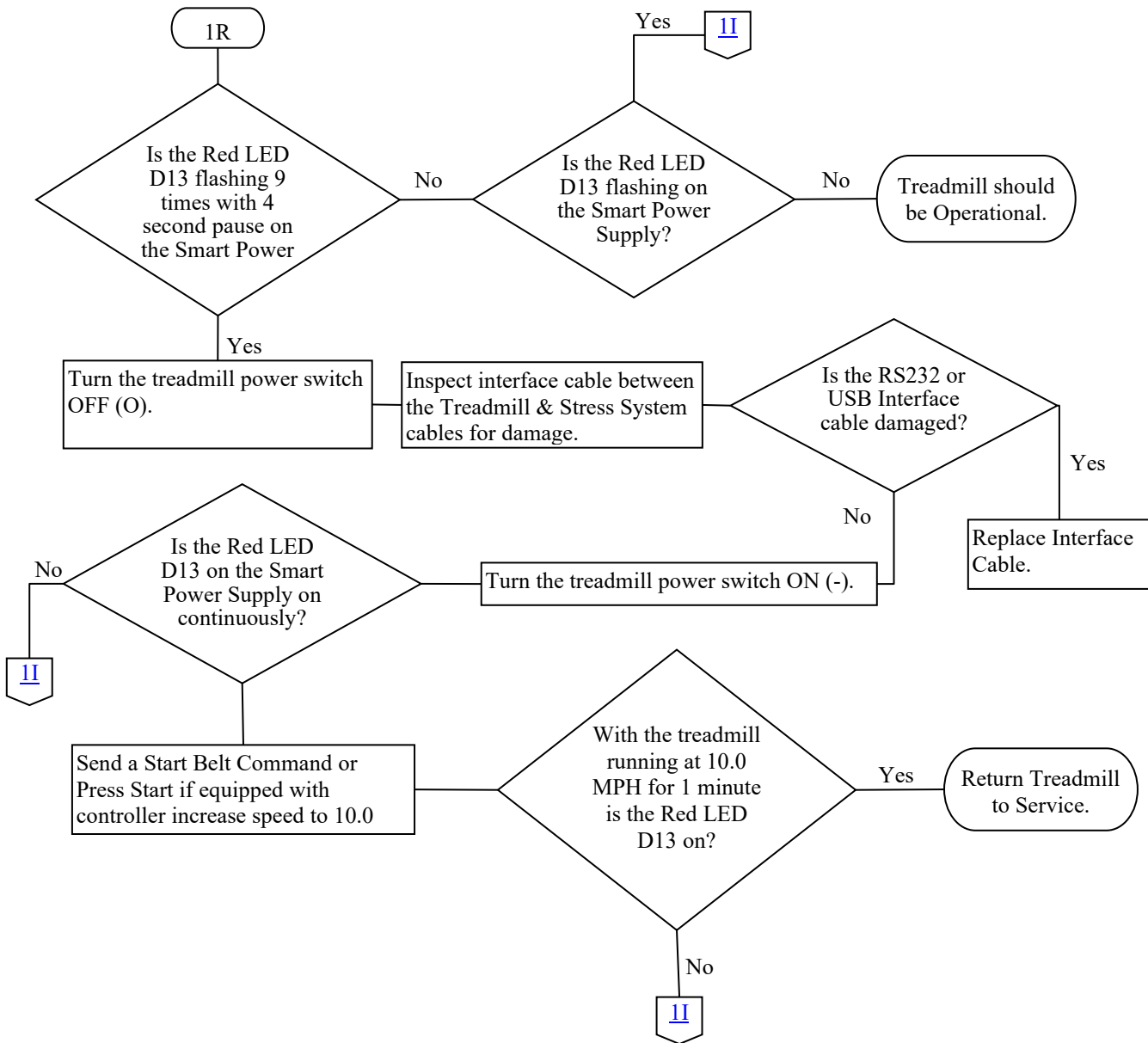

## Smart Power Supply Error Code 10

Consult the factory for trouble shooting.

Full Vision Inc.  
3017 Full Vision Drive  
Newton, KS 67114 USA  
<http://www.full-vision.com>  
Phone: (316)-283-3344  
Fax: (316)-283-9522  
Email: [sales2@full-vision.com](mailto:sales2@full-vision.com)

# Control Console Communication Flow Chart 1S

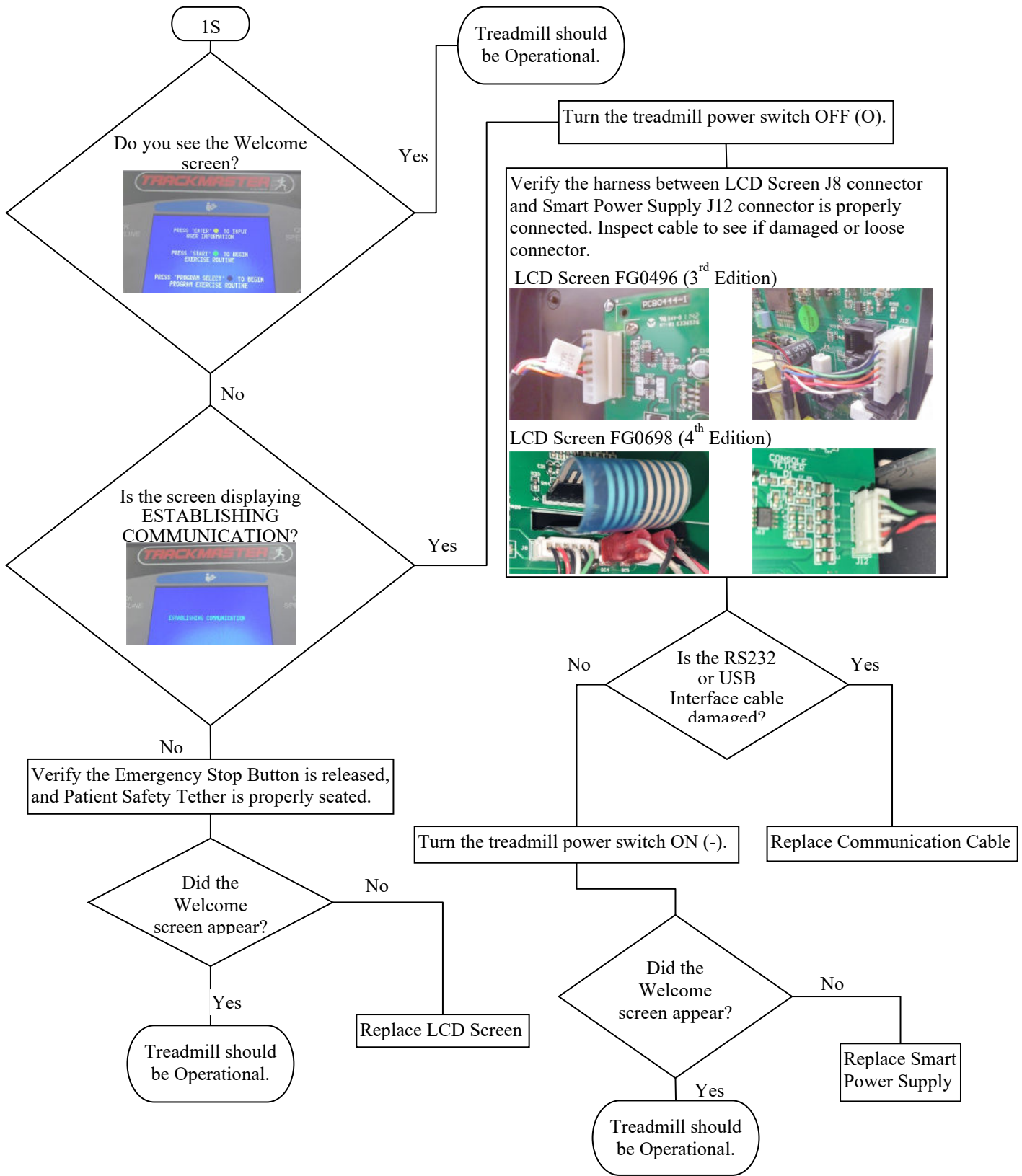

## Drive PC2303-012-N Status LED Code List

When the drive is faulted, the Status LED blinks out the fault code. The Status LED blinks the proper number of times, pauses with the Status LED off, and then repeats the blink code.

Status Code	Description	Fault Retention
No Blink	No faults, power stage enabled	-
Fast Blink	No faults, power stage disabled	-
LED Off	Ac line power insufficient	-
1 Blink	PWM_CMD Stuck Low	Latched (Consult Factory)
2 Blink	Gcoder Feedback Error	Latched (Consult Factory)
3 Blink	Not Used	-
4 Blink	Output Over Current	Latched (Consult Factory)
5 Blink	Control Supply Under Voltage	Self Resetting
6 Blink	Drive Over Temperature	Latched (Consult Factory)
7 Blink	Bus Over Voltage	Self Resetting
8 Blink	Output Short Circuit	Latched (Consult Factory)



# Removal and Replacement of Components

## Comprehensive Tool List

*Screwdrivers - Flat Head 3/32", 1/4" & 3/8" blades, T15 Torx blade.*

*Nut Drivers - 1/4", 5/16".*

*Hex Key Wrenches - 1/8", 5/32", 1/4", 3/16", 5/16".*

*T-Handle Hex Key Wrenches - 1/4", 5/16".*

*3/8" Drive Hex Bit Sockets - 1/8", 5/32", 1/4", 3/16", 5/16".*

*3/8" Drive SAE Sockets - 3/32", 3/16", 1/4", 5/16", 7/16", 1/2", 9/16", 3/4".*

*3/8" Drive Ratchet & 6" Extension.*

*Combination SAE Wrenches - 3/16", 1/4", 5/16", 7/16", 1/2", 9/16" (need two), 3/4".*

*8" Adjustable Wrench.*

*Pliers - Standard, Needle Nose (need two), Wire Cutters.*

*Utility Knife.*

*12' Tape Measure.*

*Multi Meter.*

*Grounded Wrist Strap.*

*Windows 10 Laptop Computer.*

*12' Foot Long USB or RS232 Communications Cable.*

## Hood Removal Procedure TMX428 Series

### *Tools Required*

*1/4" Nut Driver, or Flat Blade Screwdriver*

*Approximate time to complete 10 min*

1. Turn the treadmill's power switch to the OFF position.
2. Unplug the treadmill from the wall receptacle.
3. Allow treadmill to discharge for 3 minutes.
4. Remove the 5 hood securing screws (2 on the front and 3 on the back side of the treadmill).
5. Remove hood and set aside.
6. Reverse procedure to reinstall hood.

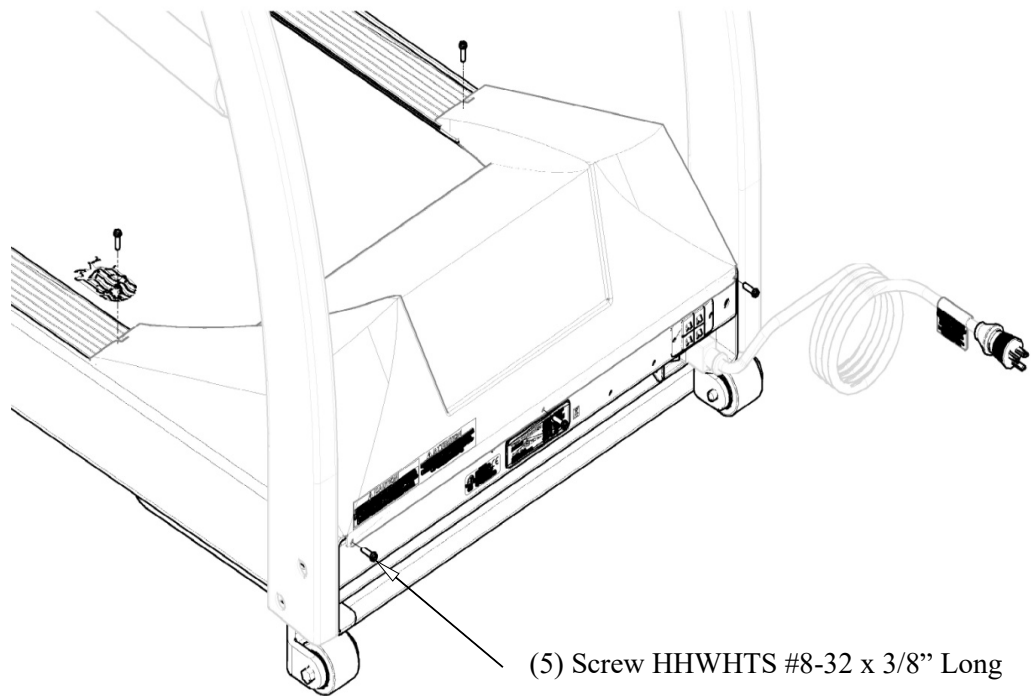

## Kollmorgen Drive Motor Replacement TMX428 Series

### Tools Required

1/4" Nut Driver or Flat Blade Screwdriver

7/16" wrench and socket

9/16" wrench and socket

3/4" wrench and socket

3/16" Hex key wrench or Hex bit socket

3/32" Hex key wrench or Hex bit socket

Approximate time to complete 1 hr 30 min

1. Elevate the treadmill with the test plug to approximately 15% grade.
2. Turn the treadmill main power switch to the OFF position.
3. Unplug the treadmill from the wall receptacle.
4. Allow the treadmill to discharge for 1 minute.
5. Remove the (5) hood securing screws.
6. Remove the hood and set it aside.

---

**CAUTION: Use ESD precautions, including wearing a grounding wrist strap that is connected to an exposed metal connection point on the treadmill chassis.**

---

7. Turn the treadmill main power switch to the OFF position.
8. Unplug the treadmill from the wall receptacle.
9. Allow treadmill to discharge for 3 minutes.
10. Remove the (5) hood securing screws.
11. Remove hood and set aside.
12. Remove Motor Feedback 6-pin cable on J1 from drive.
13. Remove Motor Power 4-pin cable on TB2 from drive.
14. With 3/4" wrench and socket loosen spring tension, slide belt off the sprocket allowing the motor to pivot, gaining access to the motor mount bolts.
15. With 1/4" hex socket or flat blade Screwdriver remove the (4) 1/4" plastic clamps on the Motor Feedback & Power wires.
16. With 7/16" wrench and socket remove the 4 bolts securing the motor mount to the frame.
17. Lift the motor assembly out of the treadmill.
18. With 9/16" wrench and socket remove the pivot bolt.
19. Remove drive sprocket from motor shaft by loosening the two 3/32" set screws on its hub, then slide it off.
20. Remove flywheel from motor shaft by loosening the two 3/16" set screws on its hub then slide it off.
21. Slide the flywheel and 1/8" key on the new motor shaft; make sure the flywheel does not rub the plastic housing creating a motor noise.
22. Slide drive sprocket and 1/8" key on the motor shaft approximately in the same location from old motor.
23. Tighten the setscrews on the hub, set key setscrew first then the other one.
24. Reinstall the new motor to existing motor base plate.
25. Tighten the pivot bolt until free movement of the motor is removed.
26. Reinstall motor, making sure the isolator mounts are in place.
27. When tightening the 4 bolts, tighten equality without over tightening.
28. Adjust speed sensor to magnet on the flywheel to approximately:  
Hall Effect Sensor 1/4"                      Reed Sensor 1/16"



29. Reinstall (4) 1/4" plastic clamps on the Motor Feedback & Power wires.
30. Reconnect Motor Feedback 6-pin cable to J1 on the drive.
31. Reconnect Motor Power 4-pin cable to TB2 on the drive.
32. See [Drive Belt Tension Adjustment](#) to tension drive belt properly.
33. After installation run treadmill checking for excess vibration and noise from the motor area.
34. Replace the hood and screws (5).

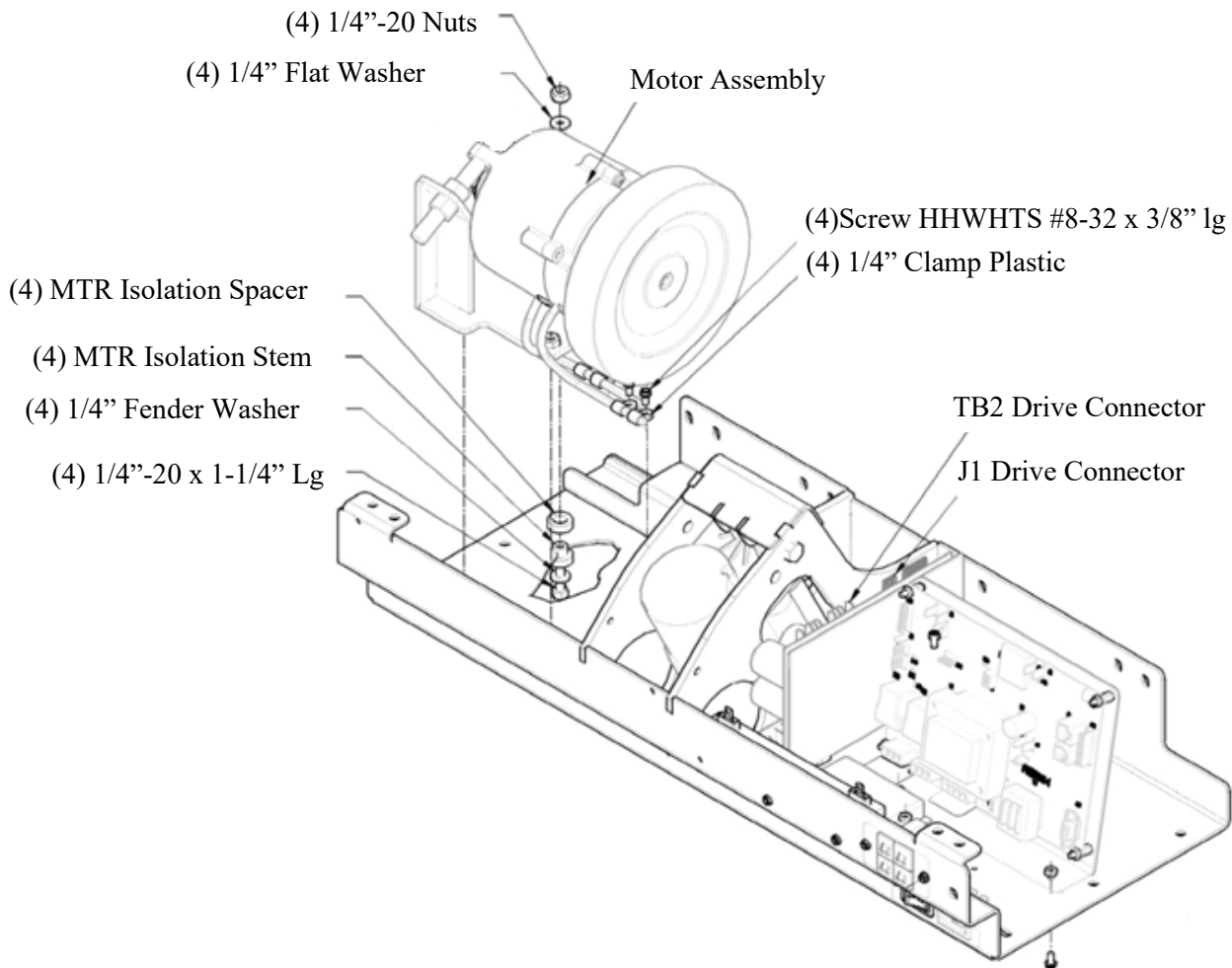

## Quantum/Trutech Drive Motor Replacement TMX428 Series

### Tools Required

1/4" Nut Driver or Flat Blade Screwdriver

7/16" Wrench and Socket

5/8" Wrench and Socket

3/4" Wrench and Socket

Grounding Wrist Strap

Approximate time to complete: 1. hr and 30 min

1. Elevate the treadmill with the test plug to approximately 15% grade.
2. Turn the treadmill main power switch to the OFF position.
3. Unplug the treadmill from the wall receptacle.
4. Allow the treadmill to discharge for 1 minute.
5. Remove the (5) hood securing screws.
6. Remove the hood and set it aside.

---

**CAUTION: Use ESD precautions, including wearing a grounding wrist strap that is connected to an exposed metal connection point on the treadmill chassis.**

---

7. Detach the External Speed Sensor w/ Harness from the Motor Velcro mount. Carefully set Sensor aside.
8. Remove the Motor Power 4-pin cable on J2 from the Drive Board.

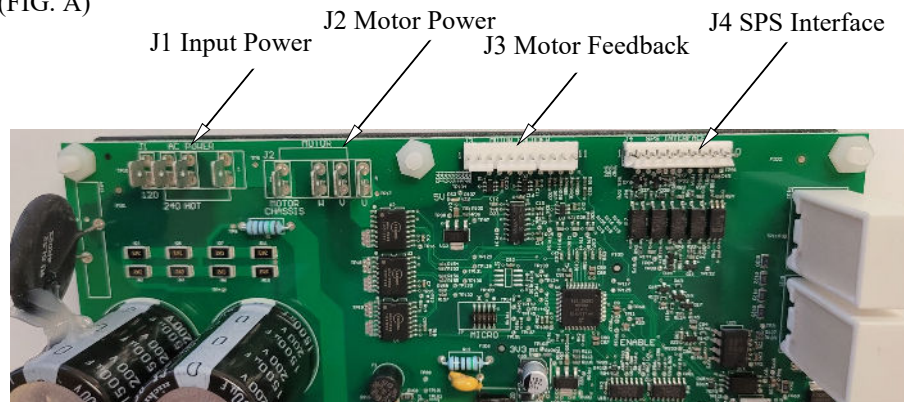

9. With the 1/4" hex socket or flat blade screwdriver, remove the (2) 1/4" plastic clamps on the Motor Power 4-pin cable. Remove Zip Tie that secures 4-pin cable to Motor Pan frame.
10. Remove the Motor Feedback 11-pin cable on J3 from the Drive Board.
11. Detach the Motor Feedback 11-wire cable from the Motor Encoder and remove it from the Motor Pan routing holes.
12. With the 3/4" Wrench and Socket, loosen the belt tension and slide the belt off the sprocket, allowing the Motor to pivot and gaining access to the (4) motor mount bolts.
13. With the 7/16" Wrench and Socket, remove the 4 bolts securing the motor mount to the frame.
14. Lift the Motor Assembly out of the Motor Pan.
15. Install the new Motor Assembly in the Motor Pan.

---

**NOTE: There are two approved styles of the Patient Safety Tether Switches.**

---

- a. Pull Tether Clip
- b. Magnetic Tether

**NOTE: Make sure the 4 isolator mounts are in place. When tightening the 4 bolts, tighten equally without over tightening.**

16. Attach the External Speed Sensor using Motor Velcro mount. Set gap to magnet on the flywheel to approximately 1/4".

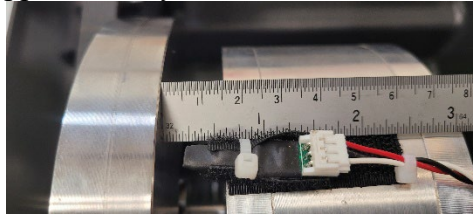

17. Route the Motor Power 4-pin cable and connect to J2 on the Drive Board.
18. Reinstall the (2) 1/4" plastic clamps on the Motor Power cable and reinstall Zip Tie to secure 4-pin cable to Motor Pan frame.
19. Route the Motor Feedback 11-pin cable through Motor Pan routing holes.
20. Reconnect the Motor Feedback 11-pin cable to J3 on the Drive, and to the Motor Encoder.
21. Install the drive belt and adjust tension. See "[Drive Belt Tension Adjustment](#)".
22. After installation, run the treadmill and check for excess vibration and noise from the motor area.
23. Calibrate the Belt Speed. See "[Calibrating Speed](#)".
24. Replace the hood and (5) screws.

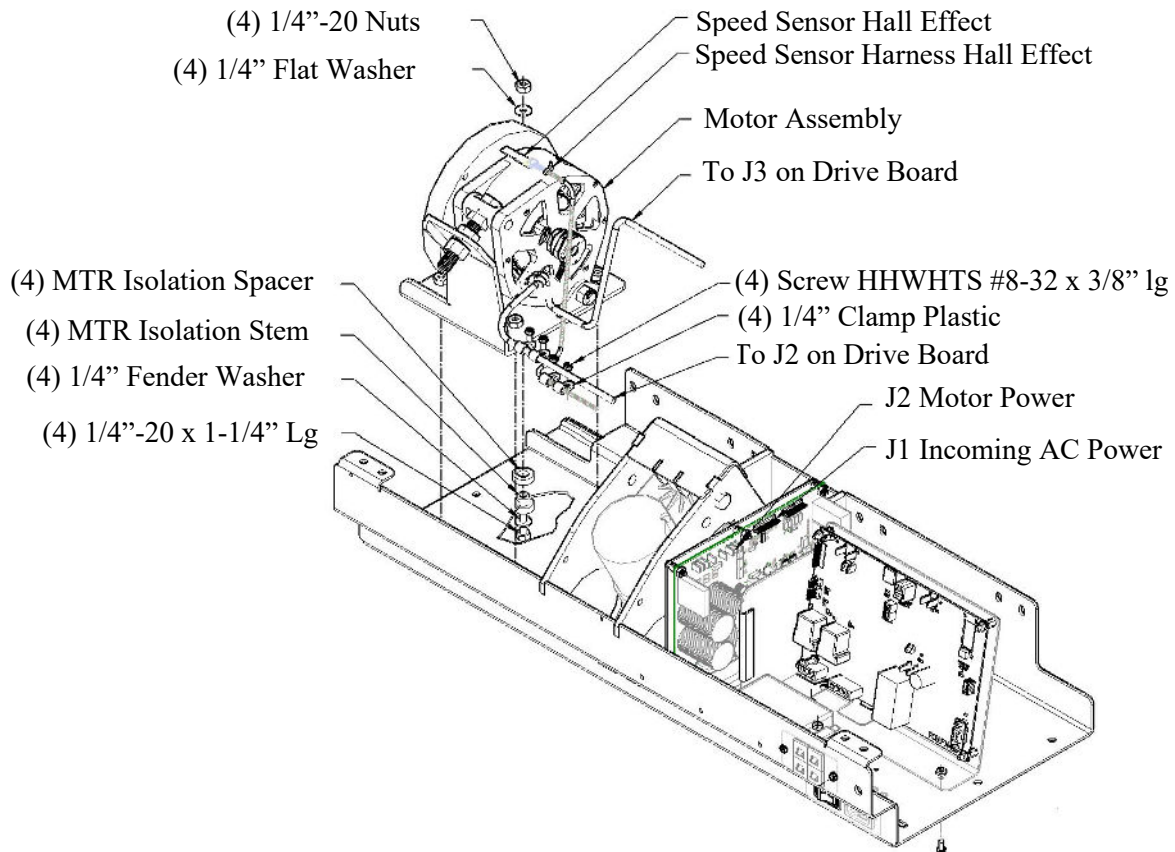

## Kollmorgen Drive Board Replacement TMX428 Series

### Tools Required

1/4" Nut Driver or Flat Blade Screwdriver

5/16" SAE Socket with 6" Extension or Nut Drive

Approximate time to complete 45 min

1. Elevate the treadmill to approximately 15% grade.
2. Turn the treadmill main power switch to the OFF position.
3. Unplug the treadmill from the wall receptacle.
4. Allow treadmill to discharge for 3 minutes.
5. Remove the (5) hood securing bolts.
6. Remove hood and set aside.

---

**CAUTION: Use ESD precautions, including wearing a grounding wrist strap that is connected to an exposed metal connection point on the treadmill chassis.**

---

7. Remove Motor Feedback 6-pin cable on J1 from drive.
8. Remove 10-pin communication cable on J2 from drive.
9. Remove Incoming Power 4-pin connector on TB1 from drive.
10. Remove Motor Power 4-pin cable on TB2 from drive.
11. Remove the 3pin connector from Regen Circuit Board on front side of drive.
12. With 5/16" socket loosen front two screws and remove the back screw.
13. The drive will slide back allowing the drive to be removed.
14. Reverse procedure to reinstall Drive; see **Chapter 6 Belt Speed Calibration Procedure** (Calibration Program).

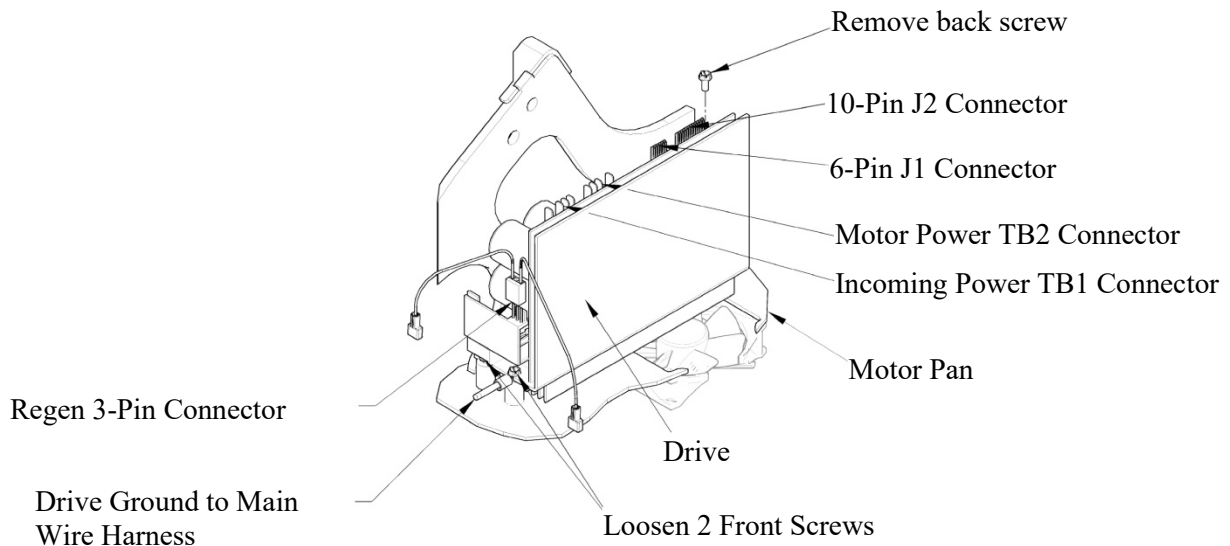

## Quantum/Trutech Drive Board Replacement TMX428 Series

### Tools Required

1/4" Nut Driver or Flat Blade screwdriver

5/16" SAE Socket with 6" Extension or Nut Drive

Grounding Wrist Strap

Approximate time to complete: 45 min

1. Elevate the treadmill to approximately 15% grade.
2. Turn the treadmill main power switch to the OFF position.
3. Unplug the treadmill from the wall receptacle.
4. Allow the treadmill to discharge for 1 minute.
5. Remove the (5) hood-securing bolts.
6. Remove the hood and set it aside.

---

**CAUTION: Use ESD precautions, including wearing a grounding wrist strap that is connected to an exposed metal connection point on the treadmill chassis.**

---

7. Remove the Incoming Power 4-pin connector on J1 from the Drive Board.
8. Remove the Motor Power 4-pin cable on J2 from the Drive Board.
9. Remove the Motor Feedback 11-pin cable on J3 from the Drive Board.
10. Remove the 10-pin communication cable on J4 from the Drive Board.

(FIG. A)

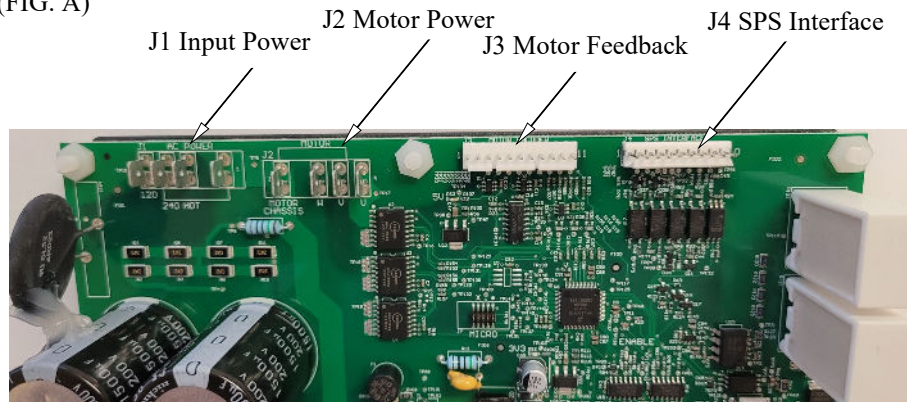

11. With the 5/16" SAE Socket remove the two front Drive Mount Frame nuts from beneath the Motor Pan and loosen the 1/4" rear screw from above.

---

**NOTE: The location of the Green w/Y ground wire under the front of Drive Mount Frame.**

---

12. Lift the front of Drive Board Assembly and slide forward to remove.
13. Reverse the procedure to reinstall the Drive Board Assembly.
14. Calibrate the Belt Speed. See "**Error! Reference source not found.**".

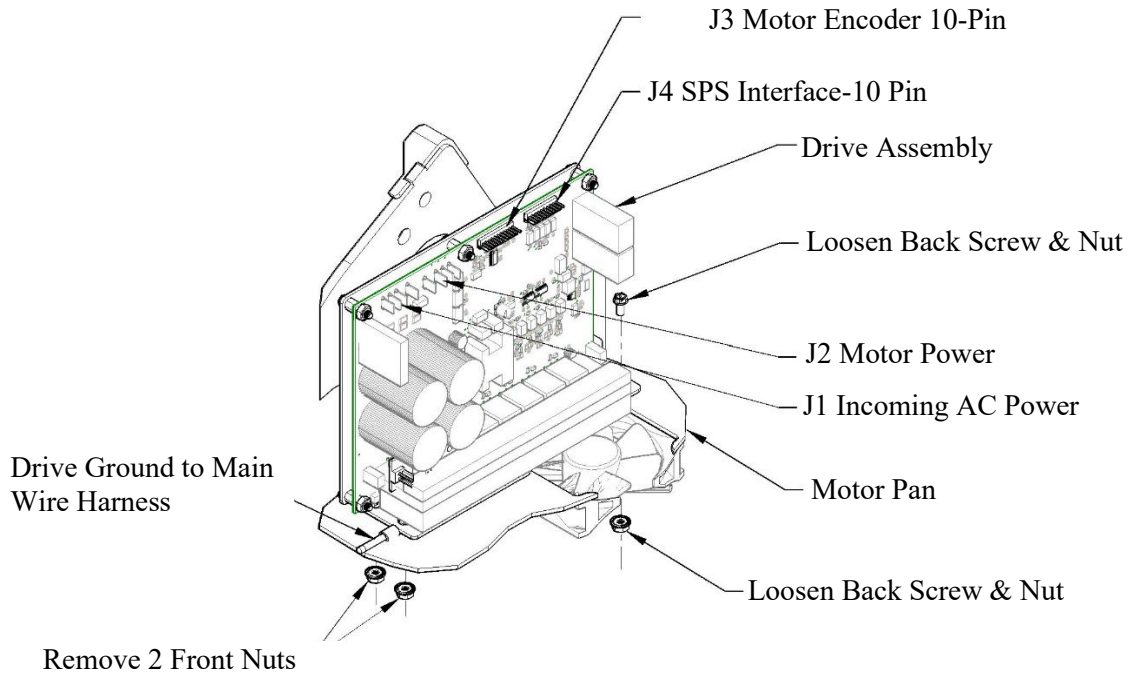

## Conversion Kit Quantum/Trutech TMX428 Series

### Tools Required

1/4" Nut Driver or Flat Blade screwdriver

7/16" Wrench and Socket

9/16" Wrench and Socket

5/8" Wrench and Socket

3/4" Wrench and Socket

3/16" Hex Key Wrench or Hex Bit Socket

3/32" SAE Wrench or SAE Socket

Grounding Wrist Strap

Approximate time to complete: 1. hr and 30 min

1. Elevate the treadmill with the test plug to approximately 15% grade.
2. Turn the treadmill main power switch to the OFF position.
3. Unplug the treadmill from the wall receptacle.
4. Allow the treadmill to discharge for 1 minute.
5. Remove the (5) hood securing screws.
6. Remove the hood and set it aside.

---

**CAUTION: Use ESD precautions, including wearing a grounding wrist strap that is connected to an exposed metal connection point on the treadmill chassis.**

---

7. Remove the Motor Feedback 6-pin cable on J1 from the Drive.
8. Remove the Motor Power 4-pin cable on TB2 from the Drive.
9. With the 3/4" Wrench and socket, loosen the belt tension and slide the belt off the sprocket, allowing the motor to pivot, gaining access to the motor mount bolts.
10. With the 1/4" Nut Driver or flat blade screwdriver, remove the (4) 1/4" plastic clamps on the Motor Feedback & Power wires.
11. With the 7/16" wrench and socket, remove the 4 bolts securing the motor mount to the frame.
12. Remove Zip Tie holding motor and feedback cables to frame.
13. Lift the Motor Assembly out of the treadmill.
14. On Drive Board, remove the Motor Feedback 6-pin cable on J1 from the Drive.
15. Remove the 10-pin communication cable on J2 from the Drive.
16. Remove the Incoming Power 4-pin connector on TB1 from the Drive.
17. Remove the Motor Power 4-pin cable on TB2 from the Drive.
18. Remove the 3-pin connector from the Regen Circuit board on the front side of the Drive.
19. With the 5/16" socket, loosen the front two screws and remove the back screw.
20. The drive will slide back allowing the Drive to be removed.
21. Remove the 3 nylon standoffs below Drive.
22. Remove the Ohmite Resistor, two wire harness and nylon standoffs. This component does not get reused and may be discarded.
23. Install the new Motor Assembly in the Motor Pan.

---

**NOTE: Make sure the 4 isolator mounts are in place. When tightening the 4 bolts, tighten equally without over tightening.**

---

24. Route the new 3-wire ext. speed sensor harness, from Power Supply J10 to Motor. Connect to External Speed Sensor and attach the Sensor to Motor using Motor Velcro mount. Set gap to magnet on the flywheel to approximately 1/4".

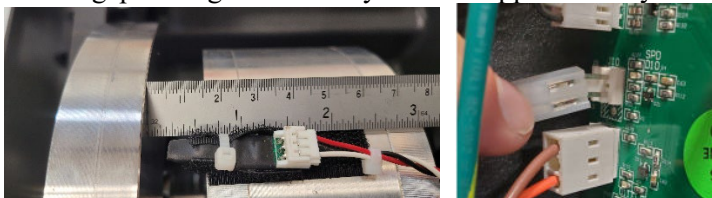

25. Route the Motor Power 4-pin cable and connect to J2 on the Drive Board.

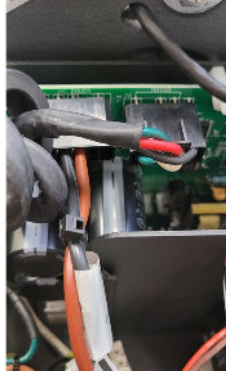

26. Install the (2) 1/4" plastic clamps on the Motor Power cable and install Zip Tie to secure 4-pin cable to Motor Pan frame.

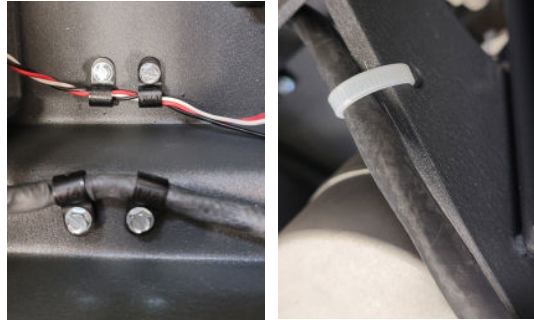

27. Route the Motor Feedback 11-pin cable through Motor Pan routing holes.

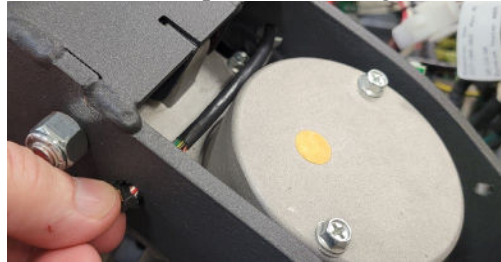

28. Connect the Motor Feedback 11-pin cable to J3 on the Drive, and to the Motor Encoder.



29. Install the drive belt and adjust tension. See [“Drive Belt Tension Adjustment”](#).  
30. Install the new Drive Board in the Motor Pan.  
31. Start the 1/4" rear screw in Motor Pan mounting hole. Slide the rear of the Drive Board Assembly beneath the 1/4" rear screw, and lower front studs through mounting holes in Motor Pan.

---

**NOTE:** Locate the ground wire under the front of Drive Mount Frame

---

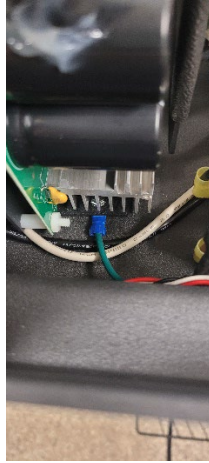

32. With the 5/16" socket install the two front Drive Mount Frame nuts from beneath the Motor Pan and tighten the 1/4" rear screw from above.
33. Connect the 10-pin communication cable on J4 from the Drive Board. (FIG. A)  
(FIG. A)

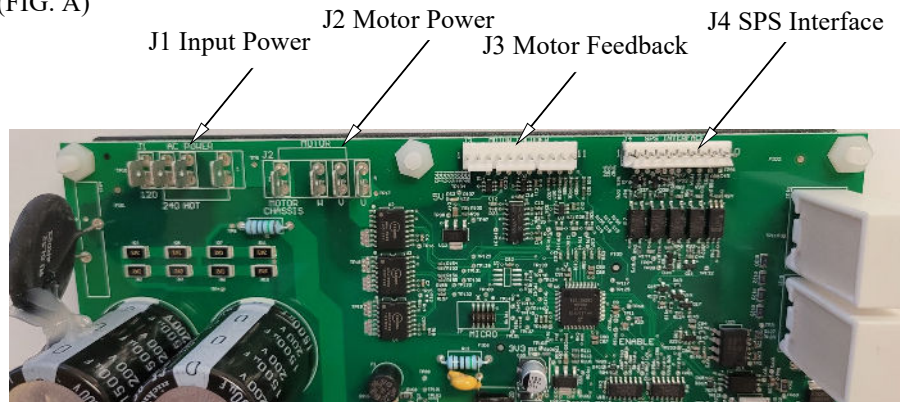

34. Connect the Motor Feedback 11-pin cable on J3 from the Drive Board. (FIG. A)
35. Connect the Motor Power 4-pin cable on J2 from the Drive Board. (FIG. A)
36. Connect the Incoming Power 4-pin connector on J1 from the Drive Board. (FIG. A)
37. Update Firmware to 1.19.XX consult factory for current firmware release.
38. Calibrate the Belt Speed. See "**Error! Reference source not found.**".
39. After calibration, run the treadmill and check for excess vibration and noise from the motor area.
40. Replace the hood and (5) screws.

## Front Roller Replacement TMX428 Series

### Tools Required

1/4" Hex Socket or Flat Blade Screwdriver

3/16" Hex Wrench or Hex Socket

Approximate time to complete 40 min

1. Turn the treadmill main power switch to the OFF position.
2. Unplug the treadmill from the wall receptacle.
3. Allow treadmill to discharge for 3 minutes.
4. Remove the (5) hood securing bolts.
5. Remove hood and set aside.
6. Use the 3/16" Allen wrench or socket to remove the button head Allen bolt securing the left and right end caps from the rear of the treadmill.
7. Remove the end caps and place to the side.
8. Use a 1/4" Allen wrench or socket to completely remove left and right tension bolts from rear roller. When removing the tension bolts maintain equal tension on the bolts to avoid stripping the threads on the tension bolt or roller.
9. Push rear roller forward as far as it will go.
10. Use a 1/4" Allen wrench or socket to remove the bolt securing the front roller to the treadmill frame.
11. Push the front roller from the right side of the treadmill to the left side and lift roller up; slip timing belt off the front roller. Lift the front roller up and out of the treadmill. Use caution to avoid pinching the timing belt.

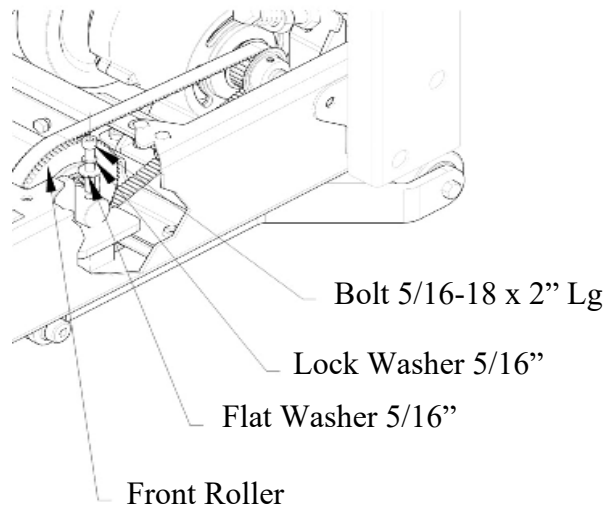

12. Slide the front roller between the running belt, place the timing belt over the sprocket of the front roller between the running belt and place the timing belt over the sprocket of the front roller. Replace the front roller. Verify the guide for the belt deck and rollers is to the left during installation. Verify the timing belt goes around the front roller sprocket and that it is not pinched.
13. Replace the securing bolt and tighten.
14. Align the bolt holes on the rear roller with the access hole of the end caps. Start the tensioning bolts on the rear roller but do not tighten.
15. Replace the left and right end caps and replace securing screws.
16. Adjust the tension of the drive belt; See "[Drive Belt Tension Adjustment](#)".
17. Follow up with Running Belt Tracking Adjustment; See "[Running Belt Tracking Adjustment](#)".

## Rear Roller Replacement TMX428 Series

### Tools Required

1/4" Hex Socket or Flat Blade Screwdriver

3/16" Hex Wrench or Hex Socket

Approximate time to complete 45 min

1. Turn the treadmill main power switch to the OFF position.
2. Unplug the treadmill from the wall receptacle.
3. Allow treadmill to discharge for 3 minutes.
4. Remove the (5) hood securing bolts.
5. Remove hood and set aside.
6. Use the 3/16" Allen wrench or socket to remove the button head Allen bolt securing the left and right end caps from the rear of the treadmill.
7. Remove the end caps and place to the side.
8. Use a 1/4" Allen wrench or socket to completely remove left and right tension bolts from rear roller. When removing the tension bolts maintain equal tension on the bolts to avoid stripping the threads on the tension bolt or roller.
9. Use a 1/4" Allen wrench or socket to completely remove left and right tension bolts from rear roller. When removing the tension bolts maintain equal tension on the bolts to avoid stripping the threads on the tension bolt or roller.
10. Push rear roller forward as far as it will go.
11. Use a 1/4" Allen wrench or socket to remove the bolt securing the front roller to the treadmill frame.
12. Push the front roller from the right side of the treadmill to the left side and lift roller up; slip timing belt off the front roller. Lift the front roller up and out of the treadmill. Use caution to avoid pinching the timing belt.
13. Push the rear roller from right side of the treadmill to the left side and lift roller up and out to remove. Replace the rear roller.
14. Slide the front roller between the running belt, place the timing belt over the sprocket of the front roller between the running belt, and place the timing belt over the sprocket of the front roller. Replace the front roller. Verify the guide for the belt deck and rollers is to the left during installation. Verify the timing belt goes around the front roller sprocket and that it is not pinched. Replace the securing bolt and tighten.
15. Align the bolt holes on the rear roller with the access hole of the end caps. Start the tensioning bolts on the rear roller but do not tighten. Replace the left and right end caps and replace securing screws.
16. Adjust the tension of the running belt; See ["Running Belt Tracking Adjustment"](#).

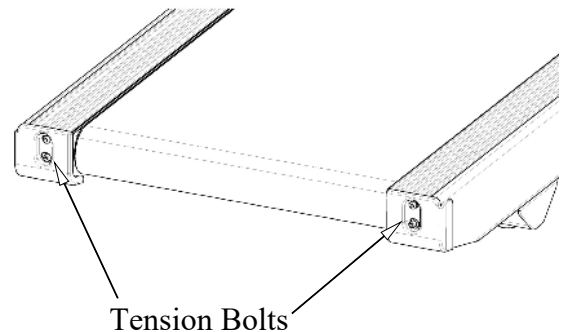

## Running Belt Replacement TMX428 Series

### Tools Required

1/4" Allen wrench or socket

3/16" Allen wrench or socket

1/2" Wrench or socket with extension

Jack stand or block capable of supporting the weight of the rear of the treadmill

Approximate Time to Complete – 1 hr 30 min

1. Elevate treadmill to 15%.
2. Turn treadmill main power switch to the OFF position.
3. Unplug treadmill plug from the wall receptacle.
4. Allow treadmill to discharge for 3 minutes.
5. Remove the (5) hood securing bolts.
6. Set hood to the side of treadmill.
7. Lift rear of the treadmill and place jack stands or block to support the rear of the treadmill.
8. Use the 3/16" Allen wrench or socket to remove the bolt securing the left and right end caps from the rear of the treadmill.
9. Remove the end caps and place to the side.
10. Use a 1/4" Allen wrench or socket to completely remove left and right tension bolts from rear roller. When removing the tension bolts maintain equal tension on the bolts to avoid stripping the threads on the tension bolt or roller.
11. Push rear roller forward as far as it will go.
12. Lift the edge of the running belt up, use 3/16" Allen wrench or socket and remove the (4) flat head Allen screws which secure the running deck cross braces. There are (4) screws total, (2) on the left side and (2) on the right side.
13. Push the deck to one side of the treadmill and from the other side lift the edge of the deck up and out over the rail. Place deck to the side.
14. Use a 1/4" Allen wrench or socket to remove bolt securing the front roller to the treadmill frame.
15. Push the front roller from the right side of the treadmill to the left side and lift roller up and slip timing belt off the front roller. Lift the front roller up and out of the treadmill. Use caution to avoid pinching the belt.
16. Slide the rear roller out of the rear of the treadmill side rails and remove from the treadmill.
17. Use 1/2" wrench or socket with extension to remove the (4) bolts securing the deck cross braces to the treadmill side channels. Remove the cross braces from the treadmill. Use caution to avoid damage to the antistatic tinsel run between the (2) front bolts. Set the cross braces and the tinsel off to the side. Verify all pieces of the deck cushions are accounted for and set off to the side.
18. Remove old running belt and replace with new running belt. Verify the guide for the belt deck and rollers is to the left during installation.
19. Replace the (2) deck braces and deck cushions; start the deck braces securing bolts but do not tighten them. Replace the antistatic tinsel using the (2) from deck brace bolts.
20. Replace the rear roller; push the rear roller as far forward as possible. Do not replace or start the tensioning bolts yet. Verify the guide for the belt deck and rollers is to the left during installation.
21. Slide the front roller between the running belt, place the timing belt over the sprocket of the front roller between the running belt, and place the timing belt over the sprocket of the front roller. Replace the front roller. Verify the guide for the belt deck and rollers is to the left during installation. Verify the timing belt goes around the front roller sprocket and that it is not pinched. Replace the securing bolt and tighten.
22. Lift up the edge of the running belt and slide the deck onto the deck braces.
23. Tighten the cross brace securing bolts. Use caution to avoid over tightening the bolts.

24. Align the bolt holes on the rear roller with the access hole of the end caps. Start the tensioning bolts on the rear roller but do not tighten.
25. Replace the left and right end caps and replace securing screws.
26. Adjust the tension of the running belt; See [“Running Belt Tracking Adjustment”](#).
27. Reinstall hood by reversing procedure.

## Deck Assembly Detail View

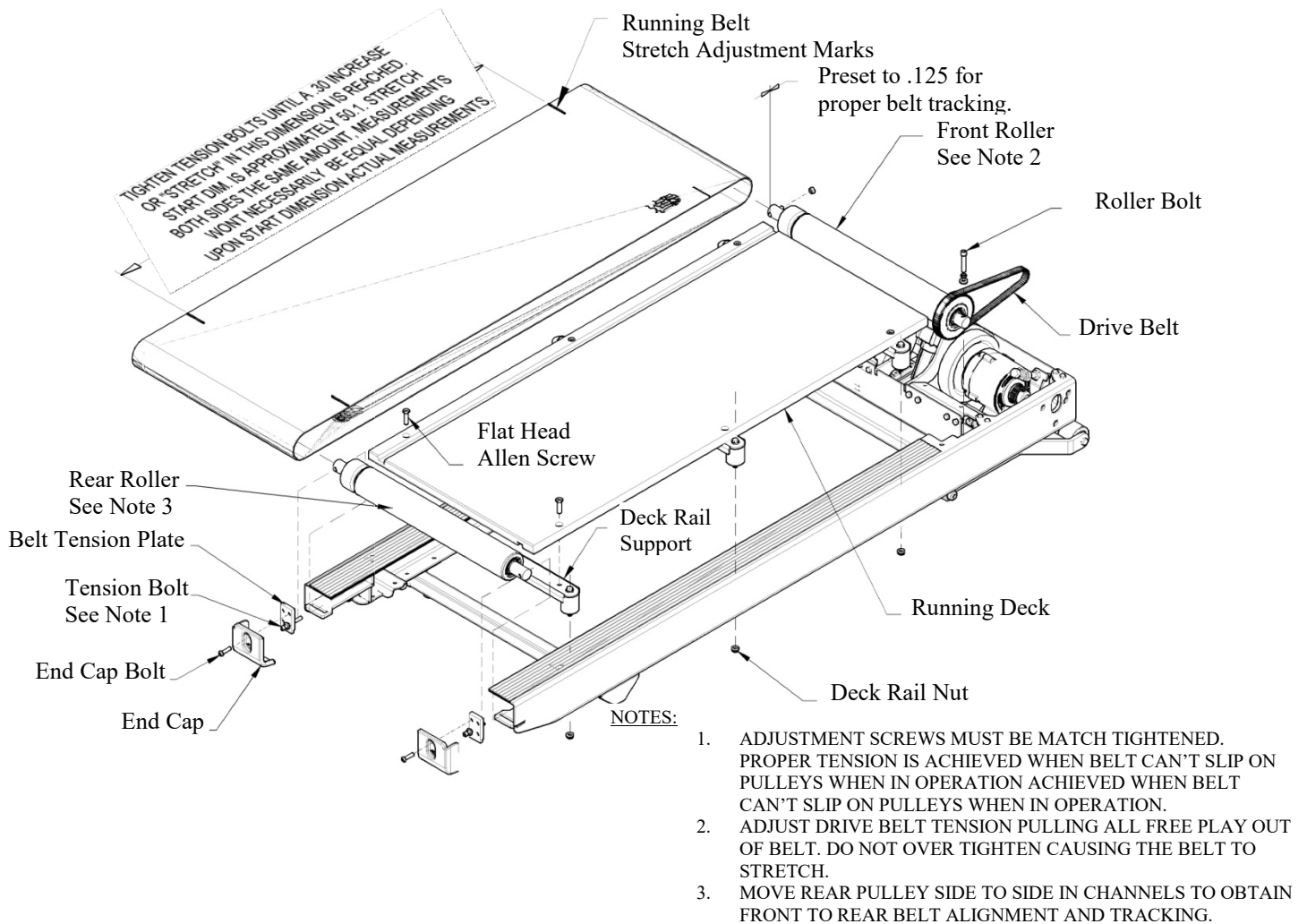

## Running Deck Replacement TMX428 Series

### *Tools Required*

*1/4" Allen Wrench or Socket*

*3/16" Allen Wrench or Socket*

*1/2" Wrench or Socket with Extension*

*Jack stand or block capable of supporting the weight of the rear of the treadmill*

*Approximate Time to Complete – 30 min*

1. Elevate treadmill to 15%.
2. Turn treadmill main power switch to the OFF position.
3. Unplug treadmill plug from the wall receptacle.
4. Allow treadmill to discharge for 3 minutes.
5. Remove the (5) hood securing bolts.
6. Set hood to the side of treadmill.
7. Lift rear of the treadmill and place jack stands or block to support the rear of the treadmill.
8. Use the 3/16" Allen wrench or socket to remove the bolt securing the left and right end caps from the rear of the treadmill.
9. See [Deck Assembly Detail View](#)
10. Remove the end caps and place to the side.
11. Use a 1/4" Allen wrench or socket to completely remove left and right tension bolts from rear roller. When removing the tension bolts maintain equal tension on the bolts to avoid stripping the threads on the tension bolt or roller.
12. Push rear roller forward as far as it will go.
13. Lift the edge of the running belt up, use 3/16" Allen wrench or socket and remove the six flat head Allen screws which secure the running deck cross braces. There are (6) screws total, (3) on the left side and (3) on the right side.
14. Push the deck to one side of the treadmill and from the other side lift the edge of the deck up and out over the side rail.
15. The deck is now ready for maintenance, replacement or to be flipped.
16. Lift up the edge of the running belt and slide the deck onto the deck braces. Replace the screws securing the deck to the deck braces and tighten. Verify the guide for the deck is to the left during installation.
17. Tighten the cross brace securing bolts. Use caution to avoid over tightening the bolts.
18. Align the bolt holes on the rear roller with the access hole of the end caps. Start the tensioning bolts on the rear roller but do not tighten.
19. Replace the left and right end caps and replace securing screws.
20. Adjust the tension of the running belt; See ["Running Belt Tracking Adjustment"](#). Reinstall hood by reversing procedure.

## Deck Cushion Replacement TMX428 Series

### *Tools Required*

*1/4" Allen Wrench or Socket*

*3/16" Allen Wrench or Socket*

*1/2" Wrench or Socket with extension*

*Jack stand or block capable of supporting the weight of the rear of the treadmill*

*Approximate Time to Complete – 1 hr*

1. Elevate treadmill to 15%.
2. Turn treadmill main power switch to the OFF position.
3. Unplug treadmill plug from the wall receptacle.
4. Allow treadmill to discharge for 3 minutes.
5. Remove the (5) hood securing bolts.
6. Set hood to the side of treadmill.
7. Lift rear of the treadmill and place jack stands or block to support the rear of the treadmill.
8. Use the 3/16" Allen wrench or socket to remove the bolt securing the left and right end caps from the rear of the treadmill.
9. Remove the end caps and place to the side.
10. Use a 1/4" Allen wrench or socket to completely remove left and right tension bolts from rear roller. When removing the tension bolts maintain equal tension on the bolts to avoid stripping the threads on the tension bolt or roller.
11. Push rear roller forward as far as it will go.
12. Lift the edge of the running belt up, use 3/16" Allen wrench or socket and remove the (2) flat head Allen screws which secure the running deck cross brace with the damaged deck cushions.
13. Use a 1/2" wrench or socket with extension to remove the (2) bolts securing the deck cross brace to the treadmill side channels. Remove the cross braces from the treadmill. Use caution to avoid damaged to the antistatic tinsel run between the (2) front bolts if the front cross brace is being removed.
14. Use a 1/2" socket to remove the rubber deck cushion(s) from the brace.
15. Replace the damaged deck cushion and use 1/2" socket to remove the bolt securing the rubber deck cushion(s) from the brace.
16. Verify the placement of the deck cushion(s) by referring to the [Running Belt Replacement](#) assembly drawing.
17. Replace the deck brace and deck cushions, start the deck brace securing bolts but do not tighten them. Replace the antistatic tinsel using the two front deck brace bolts if removed. (Fitness Only)
18. Lift up the edge of the running belt and slide the deck onto the deck braces. Replace the screws securing the deck to the deck braces and tighten. Verify the guide for the deck is to the left during installation.
19. Tighten the cross brace securing bolts. Use caution to avoid over tightening the bolts.
20. Align the bolt holes on the rear roller with the access hole of the end caps. Start the tensioning bolts on the rear roller but do not tighten.
21. Replace the left and right end caps and replace securing screws.
22. Adjust the tension of the running belt; See ["Running Belt Tracking Adjustment"](#).
23. Reinstall hood by reversing procedure.

## Motor Drive Belt Replacement TMX428 Series

### Tools required

1/4" Hex Wrench or Hex Socket

3/4" Open-end Wrench & Hex Socket

1/4" Hex Nut Driver or Flat Blade Screwdriver

Tape Measure

Approximate time to complete 1 hr 20min

1. Elevate treadmill to 15%.
2. Turn treadmill main power switch to the OFF position.
3. Unplug treadmill plug from the wall receptacle.
4. Allow treadmill to discharge for 3 minutes.
5. Remove the (5) hood securing bolts.
6. Set hood to the side of treadmill.
7. With 3/4" wrench and socket, loosen spring tension & slide belt off the sprocket allowing the motor to pivot.
8. Using 7/16" socket and wrench, remove the (6) bolts securing the "Bracket Motor Right Hand".
9. Loosen rear belt tension bolt, allowing the rear roller to move forward towards the front roller.
10. Remove hex socket head cap screw retaining the front roller on the right-hand side.
11. Now, lift right hand end of the front roller up enough to remove the drive belt.
12. Reverse procedure to install new drive belt.
13. After installation follow drive belt/running belt: See "[Drive Belt Tension Adjustment](#)" and "[Running Belt Tracking Adjustment](#)".

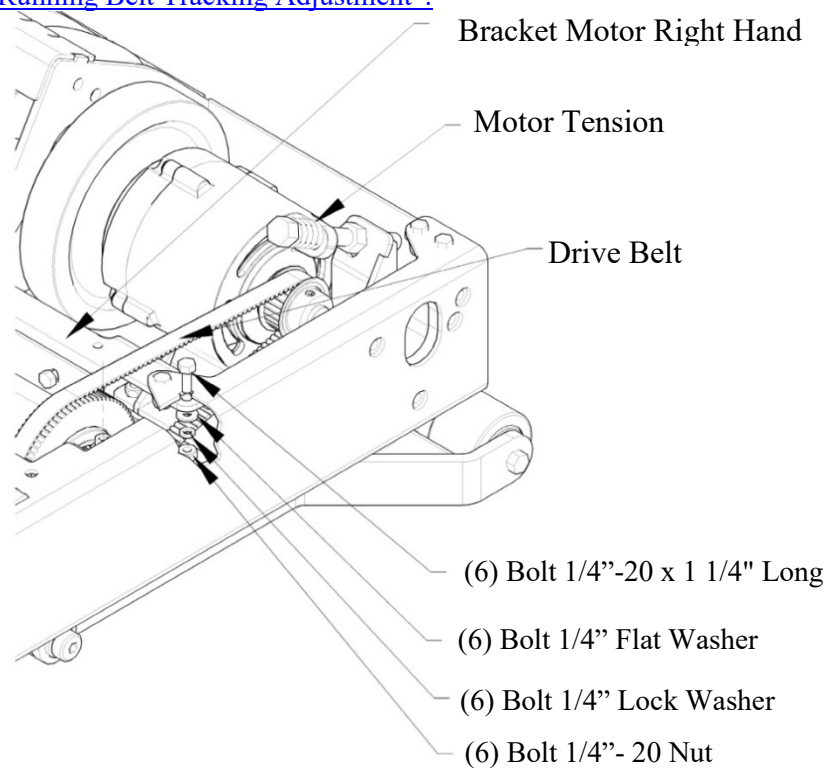

## Elevation Actuator Replacement/Adjustment TMX428 Series

### Tools Required

Tape measure

1/4" Hex Nut Driver

2 - 9/16" Wrenches or Sockets

3/8" Wide Flat Blade Screwdriver

Trackmaster Grease "Part Number 317-160-165

Shipping blanket, carpet, or cardboard

Approximate time to complete 1 hr 30 min

1. Turn treadmill main power switch to the OFF position.
2. Unplug treadmill plug from the wall receptacle.
3. Allow treadmill to discharge for 3 minutes.
4. Move the treadmill to an area large enough to lay treadmill on its side.
5. Remove the (5) hood securing bolts.
6. Set hood to the side of treadmill.
7. Unplug the treadmill actuator harness (this is a six-conductor connector attached to the actuator).
8. Cut the Zip tie that holds the wire to the motor pan gusset.
9. With blanket in suitable spot, place a foot on the treadmill side channel and grasp the handrail; pull the treadmill towards you and allow it to gently come to rest on its side.
10. With the 9/16" wrench and socket remove the top and lower bolts from the actuator.
11. When removing the bolts from the actuator: watch out for nylon washers on each side of the actuator.
12. Prior to installing the new actuator, preset the zero position. Looking from the bottom (tube end). Lightly turn the tube clockwise until it bottoms the threads or stops, ensure that the motor shaft does not turn! Now turn it counterclockwise a 1 1/2 turns and continue turning it until bolt holes in the tube is aligned with holes as it is installed.
13. Reverse procedure to install the actuator back into the treadmill. Be sure to use Trackmaster grease (quality moly-based grease) on both the bolts and nylon washers retaining it.

**NOTE: Over tightening the lower bolt will lead to a popping or creaking noise, as the treadmill is elevating.**

14. After installation, follow the calibration of grade using the grade recalibration instruction for your model of treadmill, then check for proper operation.

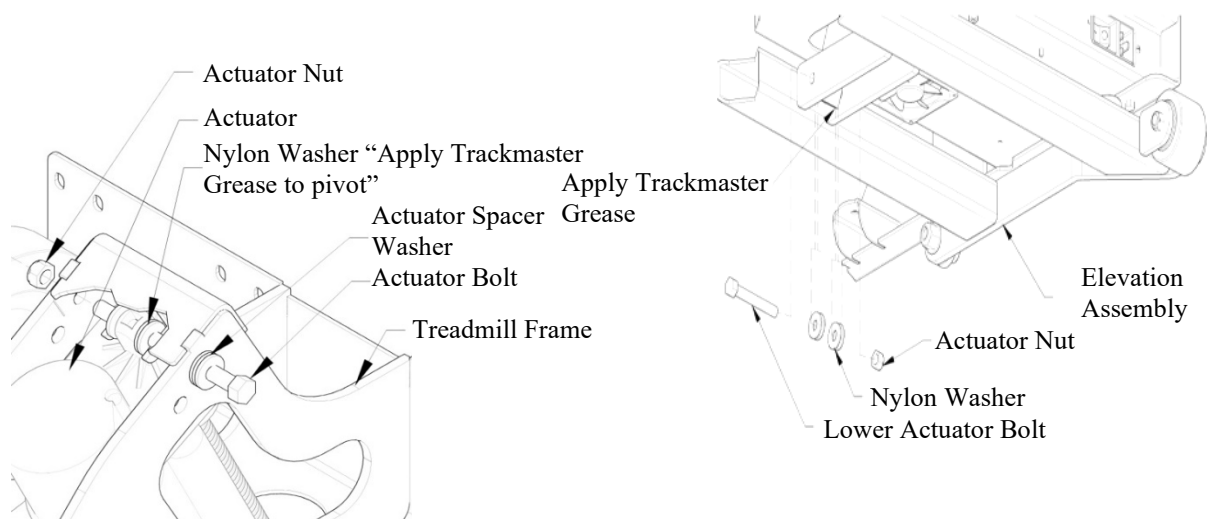

## Upgrading the Speed Sensor – 2 Wire to 3 Wire

### Tools Required

*1/4" Hex Nut Driver or Flat Blade Screwdriver*

*Long Nose Pliers*

*Grounding Wrist Strap*

*Approximate time to complete: 20 min*

1. Turn the treadmill main power switch to the OFF position.
2. Unplug the treadmill plug from the wall receptacle.
3. Allow the treadmill to discharge for 1 minute.
4. Remove the 2-wire connector from J10.



5. Feed wire connector thru hole on actuator support.
6. Slide 3 Wire Speed Sensor through rubber grommet.

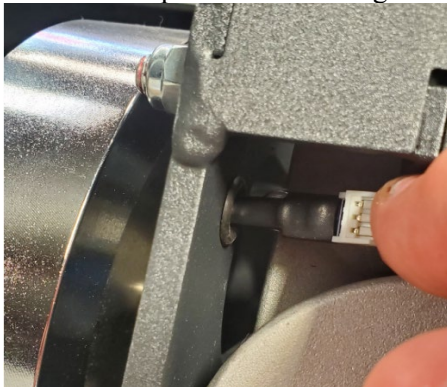

7. Adjust the speed sensor to the magnet on the flywheel to approximately 1/4"

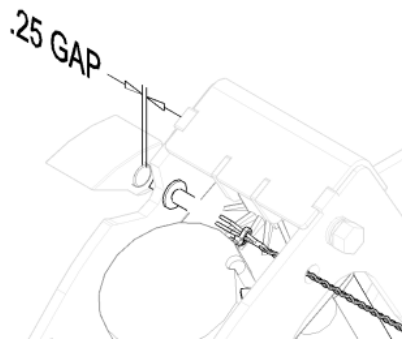

8. With the long nose pliers remove the DC Fan negative from J2.

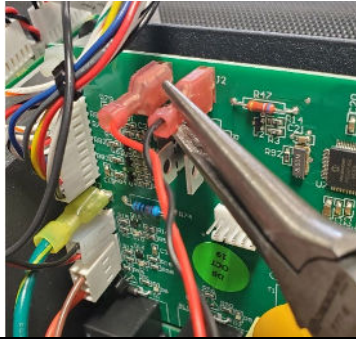

---

**CAUTION:** Use ESD precautions, including wearing a grounding wrist strap that is connected to an exposed metal connection point on the treadmill chassis.

---

9. Reconnect the DC Fan negative to 3 Wire Speed Sensor Harness receptacle tab.

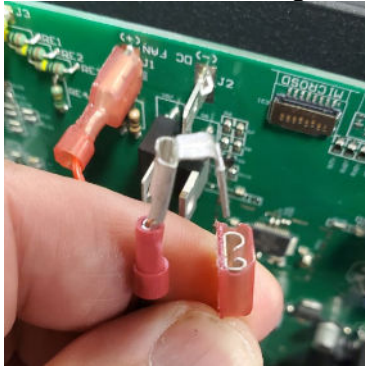

10. With long nose pliers, gently attach the 3 Wire Ground to J2 on the Smart Power Supply Board.

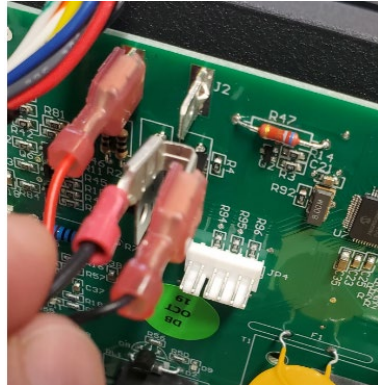

11. After replacing Speed Sensor, Perform **Belt Speed Calibration Procedure** (Calibration Program)

## Replacing the Speed Sensor – 3 Wire to 3 Wire

### Tools Required

*1/4" Hex Nut Driver or Flat Blade Screwdriver*

*Grounding Wrist Strap*

*Approximate time to complete: 20 min*

1. Turn the treadmill main power switch to the OFF position.
2. Unplug the treadmill power cord from the wall receptacle.
3. Allow the treadmill to discharge for 1 minute.
4. Remove existing 3 wire sensor.
5. Slide replacement 3 Wire Speed Sensor thru rubber grommet.

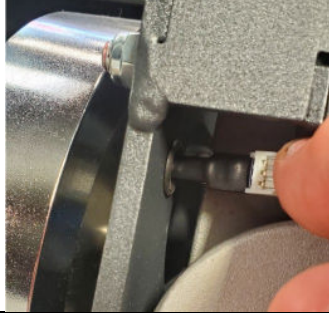

---

**CAUTION:** Use ESD precautions, including wearing a grounding wrist strap that is connected to an exposed metal connection point on the treadmill chassis.

---

6. Adjust the speed sensor to the magnet on the flywheel to approximately 1/4"

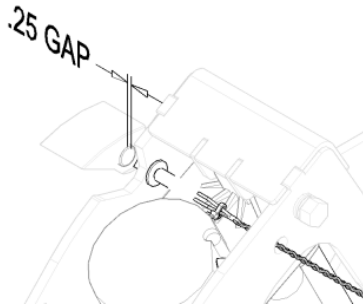

7. After replacing Speed Sensor, Perform **Belt Speed Calibration Procedure** (Calibration Program)

## Smart Power Supply Board (SPSB) Replacement TMX428 Series

### Tools required

Wire Cutters or Utility Knife

Grounding Wrist Strap

1/4" Hex Nut Driver or

3/32" Flat Blade Screwdriver

5/16" Hex Nut Driver

Approximate time to complete 1 hr 15 min

1. Turn treadmill main power switch to the OFF position.
2. Unplug treadmill plug from the wall receptacle.
3. Allow treadmill to discharge for 3 minutes.
4. Remove the (5) hood securing bolts.
5. Set hood to the side of treadmill.
6. Put on the grounding wrist strap, ground it to the power cord ground screw.
7. Unplug the 4-conductor JP2 and 3-conductor JP1 plugs from the SPSB.
8. Unplug Cooling Fan J1-Red and J2-Blk single conductor spades from the SPSB.
9. Unplug E-Stop J4-Black and J5-Gray single conductor spades from the SPSB.
10. Unplug Pull Tether J6-Black and J7-Gray single conductor spades from the SPSB.
11. Unplug Speed Sensor J10-two conductor from the SPSB.
12. Unplug Elevation Count Sensor J11-three conductor from the SPSB.
13. Unplug Drive Harness J15-ten conductor from the SPSB.
14. Remove the RS232 harness J13 by unscrewing the (2) flat head screws retaining it to the SPSB.
15. Cut the Zip tie on USB harness J14 and unplug from the SPSB.
16. Remove two control board bracket screws
17. Remove screw that holds circuit board to control board bracket. Relocate standoff and spacer transfer to new SPSB.
18. Remove the nylon nuts on the four corners of the SPSB.
19. **IMPORTANT!** Once removed, Note the position of the voltage switch on the SPSB.
20. Set voltage switch on the new SPSB as noted in STEP 19.

### WARNING

**IF WRONG VOLTAGE, DAMAGE WILL OCCUR!**

**NOTE: 4<sup>th</sup> Edition SPSB is designed with switching power supply voltage configuration(s).**

21. Reverse procedure to install the SPSB back into the treadmill.
22. After replacing the SPSB, Perform **Belt Speed Calibration Procedure** (Calibration Program)

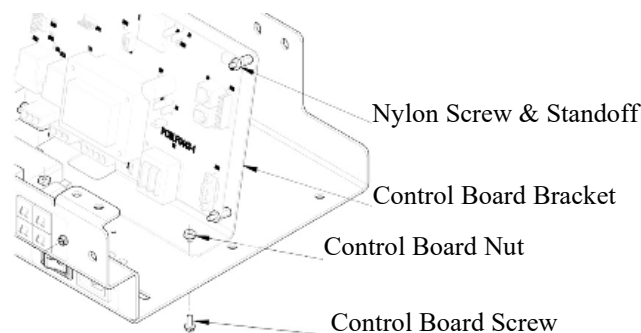

## Circuit Breaker Replacement

### Tools Required

1/4" Hex nut driver or

3/32" Flat blade electronic screwdriver

Approximate time to complete 20 min

1. Turn the treadmill main power switch to the off position.
2. Unplug treadmill plug from the wall receptacle.
3. Allow treadmill to discharge for 3 minutes.
4. Remove the (2) screws retaining the circuit breaker mounting plate.
5. Gently pull the plate out allowing wires to feed through the hole.
6. Unplug the (2) wire connectors off the circuit breaker to replace. When replacing more than one, perform the replacement one at a time to keep the wires on the correct value of circuit breaker.
7. Using a small electrical flat blade screwdriver push the holding clips on the sides of the breaker in to allow it to slide out of the plate. These are located on the backside of the plate (made as part of the breaker housing).
8. Install the new circuit breaker by sliding it into the hole until it snaps into place.
9. Reattach the wire connector by sliding them on to the terminals.
10. Once all desired breakers have been replaced, reinstall the plate with the (2) screws.
11. After installation check the unit for proper operation.

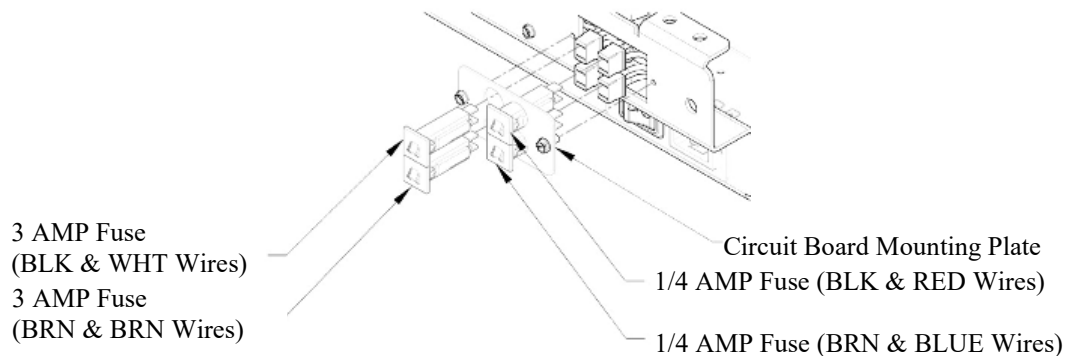

## Replace or Relocate Emergency Stop Button (ESB) & Patient Safety Tether Switch (PSTS)

### Tools Required

1/8" Allen Wrench

1/4" Flat Blade Screwdriver

2 Pair Flat Nose Pliers

Approximate time to complete 1 hr

1. Turn the treadmill main power switch to the OFF position.
2. Unplug treadmill plug from the wall receptacle.
3. Allow treadmill to discharge for 3 minutes.
4. Using a 1/8" Allen wrench, remove the (4) 10-32 screws (Fig. A) holding the ESB & PSTS assembly to the fabricated handrail.

10-32 Screw



Fig. A

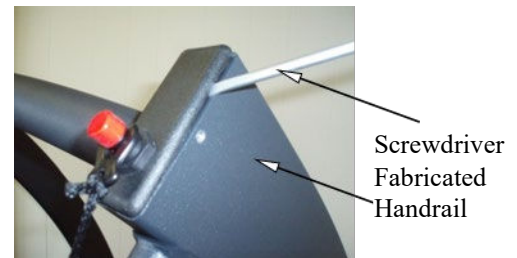
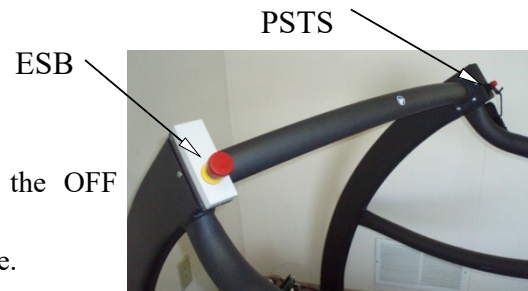

Fig. B

5. Using a flat blade screwdriver, remove the ESB & PSTS assembly from the fabricated handrail (Fig. B).
6. Completely removing the ESB & PSTS assembly and gently pulling to expose the wires.
7. Using two pairs of pliers, gently separate the connectors on the ESB (Fig. C).
8. On the PSTS using a pair of pliers, remove the connector from the tether assembly (Fig. D).

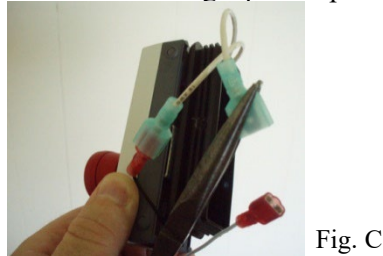

Fig. C

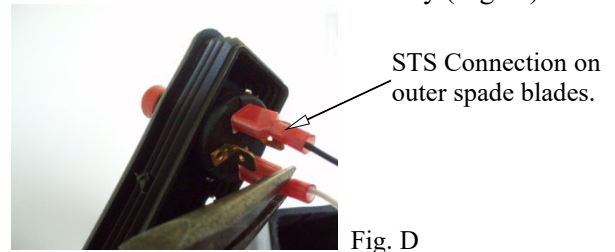
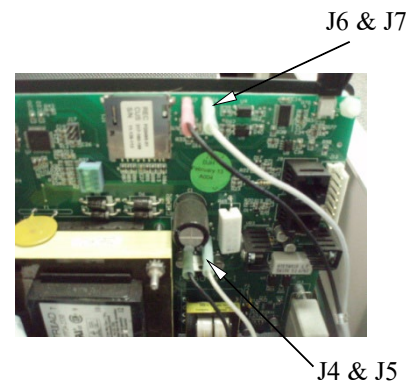

Fig. D

9. Reverse Steps 1 thru 8 to reinstall ESB & PSTS.
10. Remove the (5) hood securing bolts.
11. Remove hood and set aside.
12. Since relocating the ESB & PSTS, we will need to swap J4 & J5 with J6 & J7 on the controller board. Use caution; carefully remove the wires with pliers and slowly wiggle up and down while pulling. Avoid causing excessive flexing to the board.
13. Replace the hood. Secure the hood using original screws.



## Validate Relocate ESB and PSTS Operation

### Tools Required

#### Test Plug

#### Approximate time to complete 20 min

1. Plug treadmill power cord back into wall outlet.
2. Turn on the ON/OFF switch on the front of the treadmill.
3. Using the test plug, elevate the treadmill to 20% elevation and 2.0 MPH.
4. Pull the PSTS tether. The treadmill should come to a gradual stop and stay at 0.0 MPH for approximately 3 minutes. You may hear the motor humming as it applies resistive load when you try to move the belt.
5. Restore the PSTS and restart the treadmill using the test plug. Elevate the treadmill to 20% elevation and 2.0 MPH.
6. Press the ESB; the treadmill will come to a gradual stop with the running belt will freewheel.
7. The validation of relocating the ESB and PSTS is now complete once the treadmill has passed the above test.
8. Check to make sure all screws are properly tightened.

## Replacing the Center Handrail

### Tools Required

1/8" Allen Wrench

5/32" Allen Wrench

5/16" Allen Wrench

Grounding Wrist Strap

#### Approximate time to complete: 30 min

1. Turn the treadmill's power switch to the OFF position.
2. Unplug the treadmill from the wall receptacle.
3. Allow the treadmill to discharge for 1 minute.
4. Remove the ESB or PSTS. See [Relocate Emergency Stop Button \(ESB\) & Patient Safety Tether Switch \(PSTS\)](#)

---

**CAUTION: Use ESD precautions, including wearing a grounding wrist strap that is connected to an exposed metal connection point on the treadmill chassis.**

---

5. With the 5/32" Allen Wrench, remove the eight 1/4"-20 screws holding the center handrail to the handrail assembly.
6. Feed wire harness through center handrail.

---

**NOTE: Pay close attention when removing as to not damage the wires running through the center handrail assembly. The center handrail is ready to be replaced.**

---

7. Reverse steps 1 through step 6 to install replacement center handrail.

ESB or PSTS Assembly

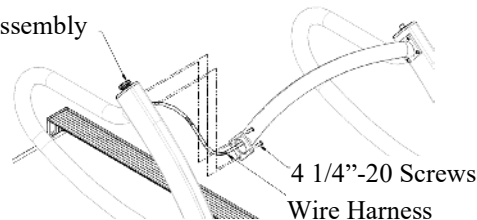

## Replacing the Right or Left Handrail

### Tools Required

1/8" Allen Wrench

5/32" Allen Wrench

5/16" Allen Wrench

Flat Blade Screwdriver

Grounding Wrist Strap

*Approximate time to complete: 30 min*

**NOTE: When replacing all the handrails, remove the center handrail before proceeding with the left and right handrails. See Replacing the Center Handrail for instructions.**

1. Turn the treadmill's power switch to the OFF position.
2. Unplug the treadmill from the wall receptacle.
3. Allow the treadmill to discharge for 1 minute.
4. Remove the ESB or PSTS assembly.

See [Relocate Emergency Stop Button \(ESB\) & Patient Safety Tether Switch \(PSTS\)](#)

**CAUTION: Use ESD precautions, including wearing a grounding wrist strap that is connected to an exposed metal connection point on the treadmill chassis.**

5. With the 5/32" Allen Wrench, remove the four 1/4"-20 screws holding the center handrail to the handrail assembly.
6. Feed the wire harness through the handrail assembly.

**NOTE: Pay close attention not to damage the wires going through the handrail assembly.**

- a. If replacing the right handrail, only disconnect the right side ESB (normal configuration) or PSTS (alternate configuration) wires to remove the handrail.
- b. If replacing the left handrail, first disconnect the ESB (normal configuration) or PSTS (alternate configuration) on the right side and feed the wire harness through the center handrail. Then disconnect the PSTS (normal configuration) or ESB (alternate configuration) wires on the left side to remove the handrail.
7. With the flat head screwdriver, remove the two plastic caps covering the bolts on the handrail.
8. With the 5/16" Allen Wrench, remove the two 3/8"-16 screws from the handrail.

**NOTE: This allows the handrail to pivot to a resting position beside the treadmill.**

9. Remove the remaining 3/8"-16 screws and nylon washer. The handrail is ready to be replaced.
10. Reverse steps 1 through step 9 to reinstall the replacement handrail.

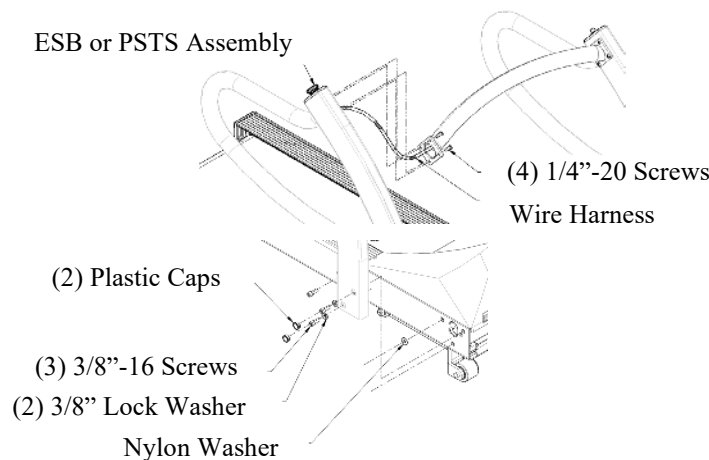

## Removing and Reinstalling the Handrails for Moving

### Tools Required

1/4" Hex Socket or Flat Blade Screwdriver

5/16" Allen Wrench

Grounding Wrist Strap

*Approximate time to complete: 45 min*

**NOTE:** This task is required only when you need to pass through a door opening less than the standard 36". It will be necessary to remove the handrail assembly if the door is not capable of being opened fully parallel to the door opening and clearance is less than 35 1/2".

1. Turn the treadmill's power switch to the OFF position.
2. Unplug the treadmill from the wall receptacle.
3. Allow the treadmill to discharge for 1 minute.
4. Remove the (5) hood securing bolts.
5. Removed the hood and set it aside.

**CAUTION:** Use ESD precautions, including wearing a grounding wrist strap that is connected to an exposed metal connection point on the treadmill chassis.

6. At the Smart Power Supply Board, disconnect the two wire harnesses from the J4 and J5 connectors (ESB) and the J6 and J7 connectors (PSTS).
7. Slide the ESB and PSTS wires through the side channel of the motor pan. Pay close attention not to damage the wires going through the handrail assembly.
8. With the flat head screwdriver, remove the two plastic caps on each side which are covering the bolts on the handrails.
9. With the 5/16" Allen Wrench, remove the two 3/8"-16 screws from each handrail. This allows the handrail to pivot to a resting position beside the treadmill.
10. Remove the remaining 3/8"-16 screws and nylon washers. The handrail is ready to be lifted off as an assembly.
11. Reverse step 1 through step 10 to reinstall the replacement handrail.

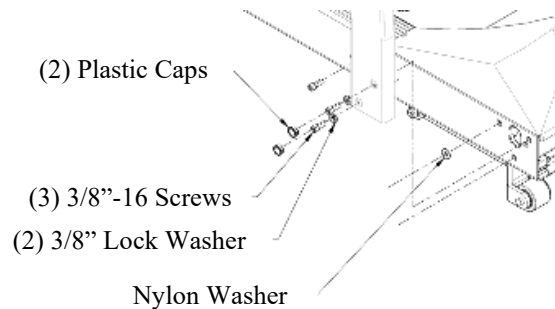

## Replacing the Main Power Switch

### Tools Required

1/4" Hex Socket or Flat Blade screwdriver

3/32" Flat Blade Screwdriver

Grounding Wrist Strap

*Approximate time to complete: 30 min*

1. Turn the treadmill main power switch to the OFF position.
2. Unplug treadmill plug from the wall receptacle.
3. Allow the treadmill to discharge for 1 minute.
4. Remove the two screws retaining the main power switch mounting plate.

**CAUTION:** Use ESD precautions, including wearing a grounding wrist strap that is connected to an exposed metal connection point on the treadmill chassis.

5. Gently pull the plate out, allowing the wires to feed through the hole.
6. Unplug the four (4) wire connectors from the main power switch to be replaced.

---

**CAUTION: When reconnecting the main power switch, insert the brown wire on top and black wire on bottom, as shown in the picture in Step 8.**

---

7. With a small electrical flat blade screwdriver, push the holding clips on the sides of the main power switch to allow it to slide out of the plate.

---

**NOTE: The clips are part of the power switch housing and located on the back side of the plate.**

---

8. Reverse step 1 through step 7 to reinstall main power switch while being sure to follow the caution in step 6.

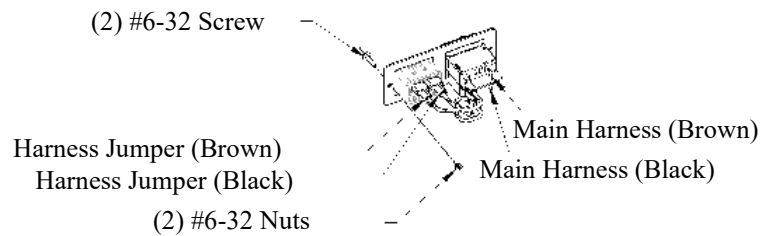

## Replacing the Power Cord

### Tools Required

7/16" Open End Wrench or Hex Socket

Approximate time to complete: 10 min

1. Turn the treadmill's power switch to the OFF position.
2. Unplug the treadmill from the wall receptacle.
3. Allow treadmill to discharge for 1 minute.
4. With the 7/16" wrench, remove the 1/4"-20 bolt, allowing the clamp to be removed from the front of the treadmill.
5. Unplug the C-19 appliance power cord from the front of the treadmill.
6. Reverse step 1 through step **Error! Reference source not found.** to reinstall new power cord.

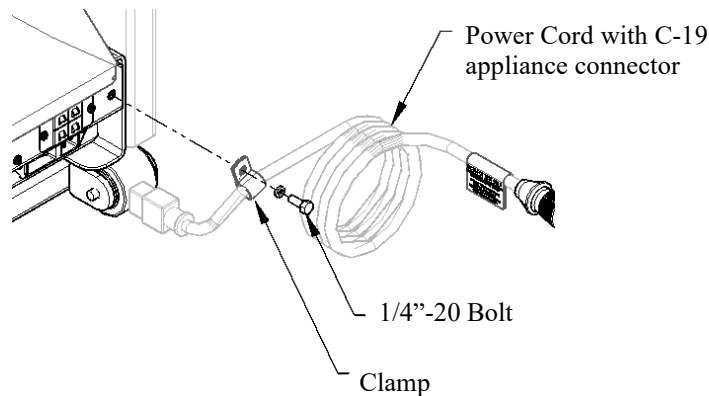

## Replacing the CE filter

### Tools Required

Flat Blade Screwdriver

Pliers or Adjustable Wrench

Grounding Wrist Strap

Approximate time to complete: 30 min

1. Turn treadmill main power switch to the OFF position.
2. Unplug the treadmill plug from the wall receptacle.
3. Allow the treadmill to discharge for 1 minute.
4. Remove the (5) hood-securing bolts.
5. Remove the hood and set it aside.

---

**CAUTION: Use ESD precautions, including wearing a grounding wrist strap that is connected to an exposed metal connection point on the treadmill chassis.**

---

6. With pliers or an adjustable wrench, hold the 11/32" nuts while removing the two (2) #8-32 screws with a flathead screwdriver.
  7. Remove the quick disconnect wire connection from the inline filter.
- 

**NOTE: The wire's location for replacement.**

---

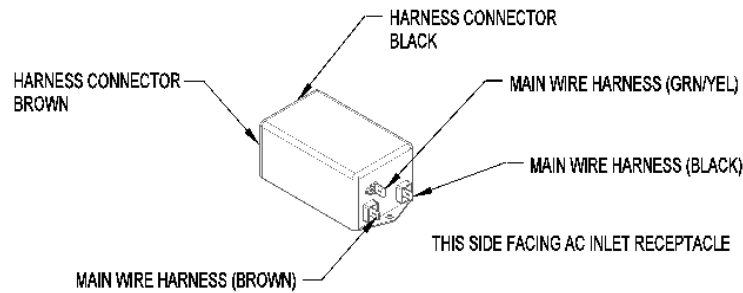

- Reverse step 1 through step 7 to reinstall replacement CE Filter.

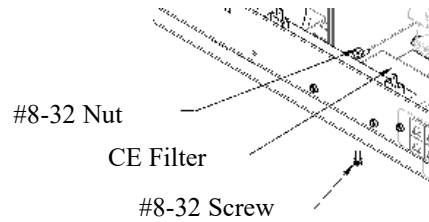

## Replacing the Relay

### Tools Required

*Flat Blade Screwdriver*

*Pliers or Adjustable Wrench*

*Grounding Wrist Strap*

*Approximate time to complete: 30 min*

- Turn treadmill main power switch to the OFF position.
- Unplug the treadmill plug from the wall receptacle.
- Allow the treadmill to discharge for 1 minute.
- Remove the (5) hood-securing bolts.
- Remove the hood and set it aside.

---

**CAUTION: Use ESD precautions, including wearing a grounding wrist strap that is connected to an exposed metal connection point on the treadmill chassis.**

---

- With pliers remove the quick disconnect wires connection from the relay.
- 

**NOTE: The wire's location for replacement.**

---

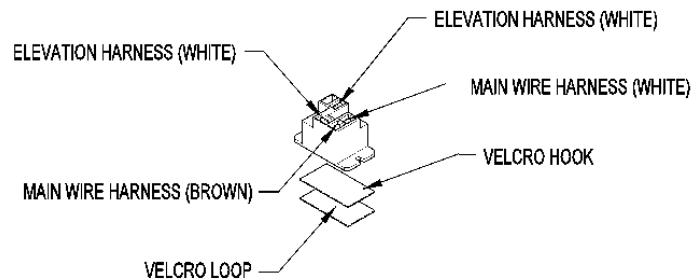

- Reverse step 1 through step 6 to reinstall replacement relay.

# Established Component Replacement Time

Hood Removal Procedure TMX428 Series	10 min
Drive Motor Replacement TMX428 Series	1 hr 30 min
Drive Replacement	45 min
Front Roller Replacement TMX428 Series	40 min
Rear Roller Replacement TMX428 Series	45 min
Running Belt Replacement TMX428 Series	1 hr 30 min
Running Deck Replacement TMX428 Series	30 min
Deck Cushion Replacement TMX428 Series	1 hr
Motor Drive Belt Replacement TMX428 Series	1 hr 20 min
Elevation Actuator Replacement/Adjustment TMX428 Series	1 hr 30 min
Smart Power Supply Relay Board Replacement TMX428 Series	1 hr 15 min
Circuit Breaker Replacement TMX428 Series	20 min
Relocate ESB and PSTS TMX428 Series	1 hr
Validate Relocate ESB and PSTS Operation TMX428 Series	20 min
Replace Emergency Stop Button (ESB) TMX428 Series	30 min
Replace Patient Stop Tether Switch (PSTS) TMX428 Series	30 min
Replace Handrail Right or Left Handrail TMX428 Series	30 min
Replace Handrail Center TMX428 Series	30 min
Handrails take off and reinstall for moving TMX428 Series	45 min
Main power switch check and replacement TMX428 Series	30 min
Run belt tracking and tension adjustment TMX428 Series	25 min
Power cord replacement TMX428 Series	10 min
CE filter replacement TMX428 Series	30 min
Ohmite resistor replacement TMX428 Series	30 min
Frame replacement TMX428 Series	7 hr 30 min
Motor pan replacement TMX428 Series	7 hr 30 min
Side channel replacement Left or Right TMX428 Series	3 hr 15 min
Rear Foot Replacement TMX428 Series	30 min
Isolator Replacement (6 isolator & belt tracking) TMX428 Series	2 hr 15 min
Main wire harness TMX428 Series	30 min
Speed Sensor Replacement TMX428 Series	20 min
End Cap Replacement TMX428 Series	15 min
Rubber Stripping On Side Channel Replacement TMX428 Series	15 min
Wheel Replacement Both TMX428 Series	10 min
RS232 Harness Replacement TMX428 Series	30 min
USB Harness Replacement TMX428 Series	30 min
Recalibrate Speed, includes time to download software TMX428 Series	30 min
Recalibrate Speed TMX428 Series	20 min

Recalibrate Elevation, included time to download software TMX428 Series	40 min
Recalibrate Elevation TMX428 Series	30 min

---

**NOTE:** Unless otherwise noted, all times are assumed to be for a treadmill fully assembled! In the event that components serviced share like disassembly procedure, both times will not apply. Example (with replacement of wire harness, speed sensor could also be replaced for no additional time). All other services not listed, including combinations of above listed services will be appointed a reasonable time by the manufacturer only! If in doubt call the manufacture before performing services (316)283-3344.

---

# Calibration TMX428 Series

## Belt Speed Calibration Procedure (Calibration Program)

### Tools Required

Calibration Program (Full\_Vision\_Calibration\_Software)

Calibration Software Version “**Full\_Vision\_Calibration\_Software\_2\_0\_1\_28**”

Stopwatch or watch with a second hand

Chalk or some other temporary marking device

Computer or laptop

Serial Communication Cable

USB Communication Cable

1. If not already using it, open the Full Vision Calibration Software.
2. In the lower left of the window, select the appropriate COM and press **Open**.

For example:



When connected, the numerical count to the right of **Sent:** will increase in value and M/C Type :

**Sent:484 | M/C Type : Quantum**

This is the indication that the communication has been established with the treadmill.

3. Select the *Advanced Control* tab.  
Select the *Set PC Time*.

---

**NOTE: When replacing the 4<sup>th</sup> Edition Smart Power Supply Board, Set PC Time is required. When updating a 3<sup>rd</sup> Edition Smart Power Supply Board this feature is not available.**

---

4. Select the **Speed Cal** tab.
5. Remove all tools from the running belt and stand clear of the running surface.
6. Select **Reset Treadmill**.

The treadmill will reset and return to the parked position.

---

**NOTE: After the down relay on the Smart Power Supple board cycles (TWO AUDIBLE CLICKS), a 20 second timer starts during which the following step (start speed calibration) must initiated. If this time window is missed, this step must be repeated.**

---

7. Select **Start Speed Cal**.  
You will be prompted with “Treadmill Entering Calibration”.
8. Click **OK**.

The running belt will pause for approximately 8 seconds and slowly increase speed, establishing multiple calibration points. This procedure may take approximately 10 to 15 seconds per calibration point, with the overall time of the speed calibration procedure taking up to 5 minutes to complete.

When calibration routing is complete the treadmill will stop and, if successful, the Speed Calibration table will have automatically updated all of the values in the *Measured Speed* column (for example see table below). At this point running belt calibration is complete.

PWM Output	Measured Speed
PWM Output 1%	0.151
PWM Output 5%	0.774
PWM Output 10%	1.552
PWM Output 20%	3.112
PWM Output 30%	4.679
PWM Output 40%	6.252
PWM Output 50%	7.834
PWM Output 60%	9.426
PWM Output 70%	11.026
PWM Output 80%	12.641
PWM Output 85%	13.252
PWM Output 87.5%	13.266
PWM Output 90%	13.285
PWM Output 93.5%	13.298

**NOTE:** If the MEASURED SPEED field(s) are displaying “0” post calibration, this indicated that the calibration failed, refer to the flow chart titled [Smart Power Supply Error Code 1 Flow Chart 1J “Bad Calibration Error \(1\)”](#). After replacement of the DRIVE BOARD or MOTOR a new SPEED Calibration is Required.

9. Select the **Basic Control** tab, select **Start Belt**, and then press ▲ one time. The running belt will start at 0.1 MPH.

**NOTE:** There are two ways to change speed.

- selecting ▲ or ▼ and adjusting to the desired speed, or
  - double-clicking on the **Set Speed** and typing in the desired speed 0.10
10. To validate the belt speed calibration, do the following:
- a. Verify a point on the run belt that can be seen plainly with each full revolution; this could be the seam or a chalk line you make on the belt.
  - b. Start the treadmill and adjust the speed to 1.0 MPH / 1.6 KPH.
  - c. Start the stopwatch when the mark on the belt passes an established point on the treadmills side rail.
  - d. Count the number of passes the mark makes in a 60 second period. The count should be 8 passes; this is within the 2% speed accuracy.
  - e. Set the speed to 5.0 MPH / 8.0 KPH.
  - f. Count the passes the belt makes but this time in a 15 second period. The count should be 10 passes; this is within the 2% speed accuracy.
  - g. Do one of the following, depending on the speed accuracy:
    - If treadmill achieved 2% accuracy, select **Stop Belt**.  
Speed calibration is complete.

**NOTE:** [“Elevation Calibration Procedure”](#) is required if a Smart Power Supply Board or Elevation Actuator was replaced, or if reported elevation is not achieving desired accuracy.

- If the treadmill does not achieve the 2% speed accuracy, this can be adjusted. When needing to further adjust the speed accuracy, this can be achieved by changing the Motor Controller Speed Offset and External Sensor Speed Offset.

**NOTE: Do not alter any parameter values without Consulting the factory. Altering the parameters may cause the treadmill to malfunction..**

---

11. Select **Stop Belt** and return to the **Speed Cal Tab**.
12. If the actual running belt is running slower than target speed, double-click the **Motor Controller Speed Offset** and decrease the percentage between 95 to 99.99%.
13. If the actual running belt is running faster than target speed, double-click the **Motor Controller Speed Offset** and increase the percentage between 100.01 to 104.99%.
14. Adjust the **External Sensor Speed Offset** to match the changed percentage of the **Motor Controller Speed Offset**.  
This is critical to ensure the treadmill does not shut down due to incorrectly reported speed verification (refer to Smart Power Supply Error Code 3 through 7 in Chapter 9, [Smart Power Supply Error Code Identification Flow Chart 1I](#)).
15. Repeat steps 6 through 10 to confirm proper adjustment of the actual running belt speed.

## Belt Speed Calibration Procedure (Controller Interface)

### Tools Required

Stopwatch or watch with a second hand

Chalk or some other temporary marking device

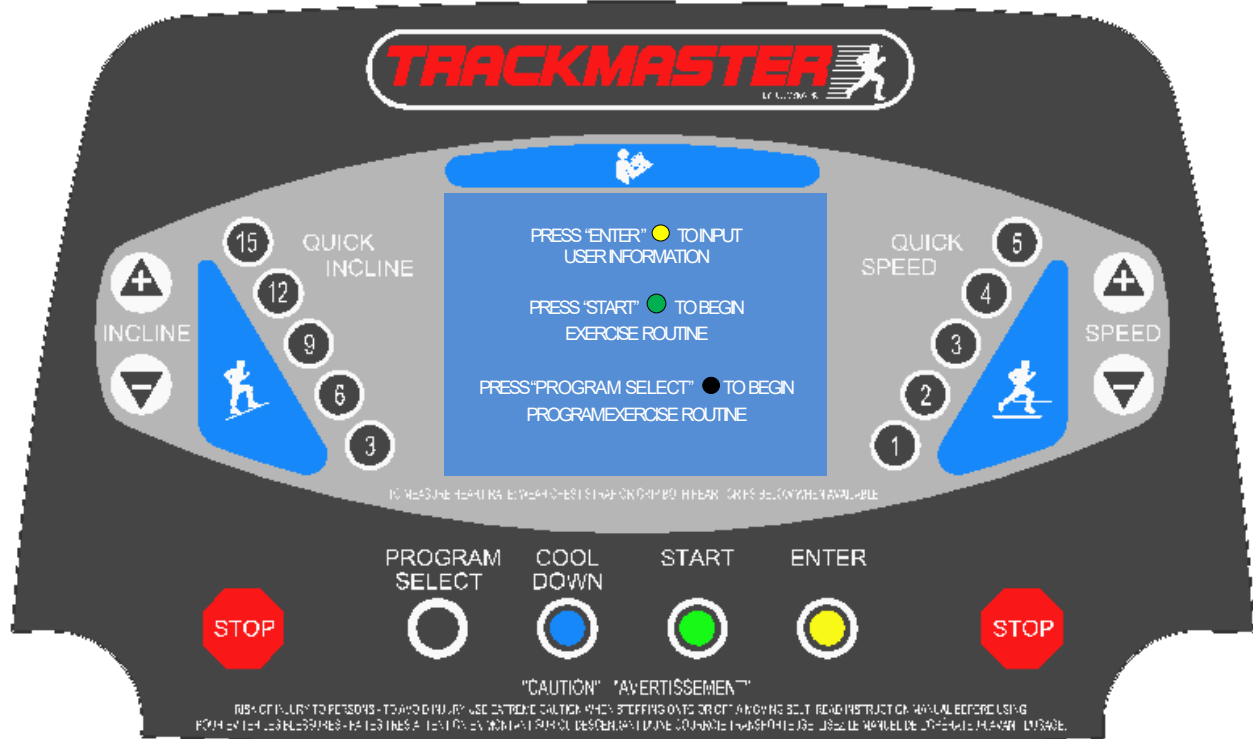

- To gain access to the parameter screen, hold down on QUICK SPEED **4** for approximately 4 seconds.
- Using the ENTER **yellow circle** or PROGRAM SELECT **black circle** to highlight **SPD 0.0**.
- Remove all tools from running belt and stand clear of running surface.
- To start the calibration procedure, hold down on QUICK SPEED **2**.
- Observe: Running belt will pause for approx. 8 seconds and slowly increase speed establishing multiple calibration points.
- When calibration routing is completed and successfully value P13 will automatically update Cal Speed Fields **P13 14925**. When calibration routine fails, value P13 will display **P13 0**. Consult factory for assistance.
- At this point, running belt calibration is complete.
- To set MPH versus KPH, position dip switch 1 when in the “OFF” position, units are set to English, and in the “ON” position, units are set to Metric.
- Select START **green circle** twice to start countdown 3, 2, 1 the running belt will start at 0.1 MPH.
- Measure belt with MPH / KPH gauge or using “Verifying Belt Speed Calibration (in the field)”. Verify within specification +/- 2%.

TMX428 VERSION 0.4							
ENTER: NEXT		PROG: PREV		+- EDIT		START: EXIT	
P00	1	P01	400000	P02	33	P03	160
P04	100	P05	150	P06	0	P07	0
P08	0	P09	0	P10	135	P11	1000
P12	25	P13	0	P14	0	P15	19
P16	96	P17	198	P18	305	P19	400
P20	495	P21	990	P22	11	P23	35
P24	0	P25	160	P26	342	P27	1000
P28	1000	P29	7615	P30	0	P31	0
P32	0	P33	4000	P34	0	P35	5
P36	7	P37	4753				
		C00	1	SPD	0.0	ELE	0.0

11. Repeat process for 2, 3, 5, 7, & 12 MPH or 4, 6, 8, 12 & 19 KPH.
12. If not with tolerance, adjust P29 value **P29 7615** then recalibrate belt.
13. Repeat steps 9 thru 11 until within tolerance.
14. Press 

## Verifying Belt Speed Calibration (in the field)

### *Tools Required*

*Stopwatch or watch with a second hand*

*Chalk or some other temporary marking device*

Verify a point on the run belt that can be seen plainly with each full revolution; this could be the seam or a chalk line you make on the belt.

1. Start the treadmill and adjust the speed to 1.0 MPH / 1.6 KPH.
2. Start the stopwatch when the mark on the belt passes an established point on the treadmills side rail.
3. Count the number of passes the mark makes in a 60 second period.
4. The count should be 8 passes plus about 7" (although 8 passes is within the 2% accuracy).
5. Next set speed to 5.0 MPH /8.0 KPH. Once again count the passes the belt makes this time in a 15 second period. You should get 10 passes + about 7", again 10 passes is satisfactory to 2% accuracy.
6. Lastly, set the speed to 10.0 MPH / 16.1 KPH. This time use a 9 second time period.
7. The mark on the belt should pass the point 12 times plus 8", 12 passes being within the required specification.
8. This verification is within the required tolerance speed of the treadmill.

## Elevation Calibration Procedure (Calibration Program)

### Tools Required

Calibration Program (Full Vision Treadmill PS New Cal)

Tape Measure

1/4" Nut Driver or Flat Headed Screw Drive

T15 Torx Screwdriver

Computer or laptop

Serial Communication Cable

USB Communication Cable

**NOTE:** "[Elevation Calibration Procedure](#)" is required if a Smart Power Supply Board or Elevation Actuator was replaced, or if reported elevation is not achieving desired accuracy.

1. If not already using it, open the Full Vision Calibration Software.
2. In the lower left of the window, select the appropriate COM and press **Open**.

For example:

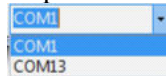

When connected, the numerical count to the right of **Sent:** will increase in value:

Sent:484

This is the indication that the communication has been established with the treadmill.

3. Select the **Grade Cal** tab.
4. Select **Test 0.5%** to elevate the treadmill 0.5% and then cycle the treadmill power. By resetting the power, the treadmill will automatically find the lower limit position.
5. Using a tape measure, verify the 0% elevation.

Refer to the "**Error! Reference source not found.**".

- a. If the zero position requires adjustment, remove actuator top cover.

VonWeise Actuator

MSI Actuator



**NOTE:** The treadmill can have either a VonWeise or MSI Actuator. The only difference is how the zero position is adjusted.

- b. Do one of the following:
  - If the position is low, adjust the upper cam (control for 0% elevation limit) with needle nose pliers clockwise into the limit switch "see note".
  - If position is high, adjust the upper cam (control for 0% elevation limit) with needle nose pliers counterclockwise away from limit switch "see note".

VonWeise Actuator

MSI Actuator



**NOTE: When adjusting the Upper Cam on the VonWeise Actuator, an audible click will be heard. Make adjustment in small increments, preferably a single click at a time.**

**On MSI Actuator, loosen screw to relieve tension, then position Upper Cam. This is a friction fit. Be careful to move in small increments, tighten screw when complete.**

- c. Repeat step 4 to 5 to reestablish 0% elevation.
6. To ensure the upper limit switch is not engaged, change the 25% default value of **481** on the **Grade Cal** tab to a new value of **500**.
7. Select **Test 25%** and verify with a tape measure that the value is 18.0" to 18.1".  
The lower cam should almost be in contact with the limits switch.  
If the **Upper Elevation Limit** is reached prior to reaching the target, the treadmill will automatically reset to the 0% elevation.
  - a. If this happens on VonWeise Actuator, use a large (.375" wide) flat blade screwdriver to rotate the lower switch cam counterclockwise the proper amount to assure the treadmill will not elevate past 25%. On MSI Actuator loosen screw to relieve tension then position lower cam. This is a friction fit be careful to move in small increments, tighten screw when complete.

VonWeise Actuator



MSI Actuator



- b. If the cam was turned to adjust the lower switch (control for 25% elevation limit); the upper cam (control for 0% elevation limit) will need to be reset to zero to allow the treadmill to park in the correct position. Repeat step 4 to 5 to reestablish 0% elevation.

**NOTE: When an adjustment on the VonWeise Actuator is made to the Lower Cam, the Upper Cam moves in tandem.**

**On MSI Actuator, when an adjustment is made to the Lower Cam, the Upper Cam does not move in tandem.**

**The LOWER SWITCH adjusts the UPPER LIMIT and the UPPER SWITCH adjust the LOWER LIMIT. If the UPPER LIMIT has been adjusted, then the LOWER LIMIT will also need to be RE-ADJUSTED and vice versa.**

8. When the desired results are achieved change the **Test 25%** value back to **481**.
9. Select **Test 0.5%**.
10. Using the tape measure, verify the elevation height Refer to the **"Error! Reference source not found."**
11. If incorrect, compensate by making small incremental adjustments of 1 to 5 counts in **Elevation Count** column next to the elevation grade being tested by typing the new value and selecting **OK** or pressing **Enter**.

Grade	Inches	MM	Elevation Count	Test
0%	2.64"	67mm	0	Home
0.5%	3.35"	85mm	19	Test 0.5%
5%	5.92"	150.4mm	93	Test 5%
10%	9.18"	233.2mm	194	Test 10%
15%	12.45"	316.2mm	298	Test 15%
20%	15.12"	384mm	389	Test 20%
25%	17.88"	454.2mm	481	Test 25%

12. Select **Test 0.5%** and recheck the measurement.

---

**NOTE: When selecting the grade being tested, the treadmill will change elevation.**

---

13. Repeat steps 9 through 12 for 5%, 10%, 15%, 20%, and 25%.
14. Cycle the power to return the treadmill to 0% elevation.
15. If the actuator cap was removed, replace the cap.

## **Elevation Calibration Procedure (Controller Interface)**

### *Tools Required*

*Tape Measure*

*1/4" Nut Driver or Flat Headed Screwdriver*

*T15 Torx Screwdriver*

1. Plug treadmill to power supply.
2. Turn ON Treadmill.
3. To set the 0% Elevation and Upper Elevation Limits.
4. Start treadmill, increase elevation to 5% and cycle treadmill power (by resetting the power, the treadmill will automatically find the lower limit position).
5. Using a tape measure, verify the 0% elevation (Refer to

6. Elevation Chart TMX428, TMX428CP, and TMX58).

5A. If the zero position requires adjustment, remove actuator top cover.

**NOTE: The treadmill can have either Von Weise or MSI Actuator. The difference is how the Zero Position is adjusted.**

VonWeise Actuator



MSI Actuator



- 5B. If the Zero Position is low, adjust the upper cam clockwise into the limit switch. If position is high adjust the upper cam counterclockwise away from limit switch.

VonWeise Actuator



MSI Actuator



**NOTE: When adjusting the Upper Cam on the Von Weise Actuator, an audible click will be heard. Make adjustments in small increments, preferably a single click at a time.**

**When adjusting the Upper Cam on the MSI Actuator, loosen screw to relieve tension, then position Upper Cam. This is a friction fit, be careful to move in small increments, tighten screw when complete.**

- 5C. Repeat step 8 to reestablish 0% elevation.

7. To gain access to the parameter screen hold down on QUICK SPEED **4** for approximately 4 seconds.
8. Using the ENTER **●** or PROGRAM SELECT **●** to highlight **P20 484**.
9. Adjustment to **P20 500** with any + or – key.
10. Using the ENTER **●** or PROGRAM SELECT, **●** highlight **ELE 0.0**.
11. Increase elevation to 25% (verify with a tape measure that the value is 18.0” to 18.2”).
12. The lower Cam should almost be in contact with limits switch.
13. If the Upper Elevation Cam comes in contact with limit switch, the treadmill will automatically reset to the 0% elevation.
  - On the Von Weise Actuator use a large (3/8” wide) flat blade Screwdriver, rotate the lower switch cam counterclockwise the proper amount to assure the treadmill will not elevate past 25%.
  - On the MSI Actuator loosen screw to relieve tension then position lower cam. This is a friction fit be careful to move in small increments, tighten screw when complete.

VonWeise Actuator

MSI Actuator

**WARNING**

**If the cam was turned to adjust the lower switch, the upper cam will need to be reset to zero to allow the treadmill to part in the correct position. Repeat Step 8 to reestablish 0% elevation.**

**NOTE: When adjustments are made to the lower cam, on the Von Weise Actuator, the upper cam moves in tandem. When adjustments are made to the lower cam on the MSI Actuator, the upper cam does not move in tandem.**

14. To gain access to the parameter screen, hold down on QUICK SPEED **4** for approximately 4 seconds.
15. Using the ENTER **●** or PROGRAM SELECT **●** highlight **ELE 0.0**.
16. To adjust elevation use any + or – key to .5% grade.
17. Using the tape measure verify the angle (Refer to

TMX428 VERSION 0.4							
ENTER: NEXT		PROG: PREV		+- EDIT		START: EXIT	
P00	1	P01	400000	P02	33	P03	160
P04	100	P05	150	P06	0	P07	0
P08	0	P09	0	P10	135	P11	1000
P12	25	P13	0	P14	0	P15	19
P16	97	P17	195	P18	295	P19	388
P20	484	P21	990	P22	11	P23	35
P24	0	P25	160	P26	342	P27	1000
P28	1000	P29	7615	P30	0	P31	0
P32	0	P33	4000	P34	0	P35	5
P36	7	P37	4753				

18. Elevation Chart TMX428, TMX428CP, and TMX58).
19. If incorrect, make adjustments to compensate on parameter P15 = .5% elevation and then use any + or – key to adjust value.
20. Lower incline & raise back up to .5% and recheck measurement.
21. Repeat procedure for P16=5%, P17=10%, P18=15%, P19=20% and P20=25%.
22. Return to 0% elevation.
23. If Actuator cap was removed, replace cap.

## Elevation Chart TMX428, TMX428CP, and TMX58

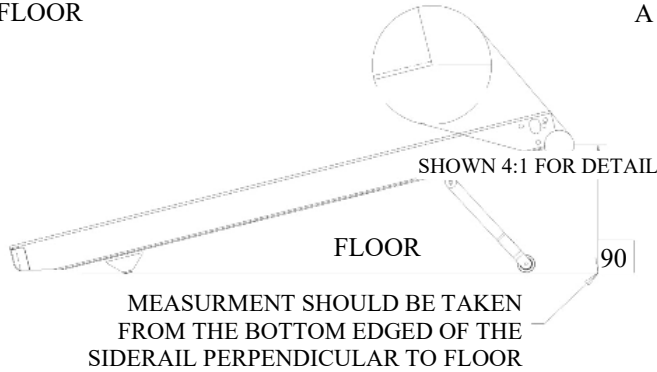
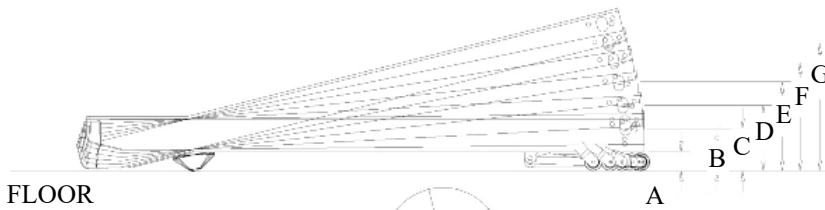

Dim.	Grade	Inches	MM
A	0%	2.64"	67mm
B	.5%	3.35"	85mm
C	5%	5.92"	150.4mm
D	10%	9.18"	233.2mm
E	15%	12.45"	316.2mm
F	20%	15.12"	384.0mm
G	25%	17.88"	454.2mm

## TMX428, TMX428CP, and TMX58 Elevation Actuator Adjustment

### VonWeise Actuator

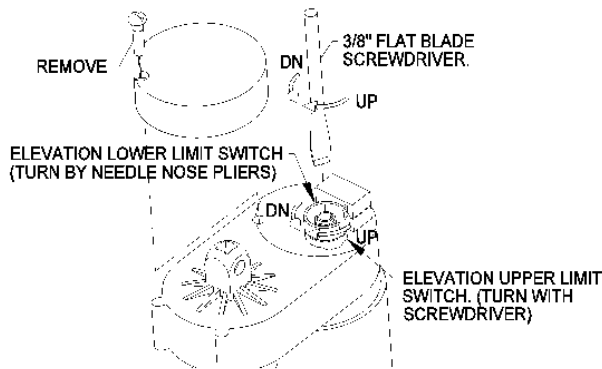

### MSI Actuator

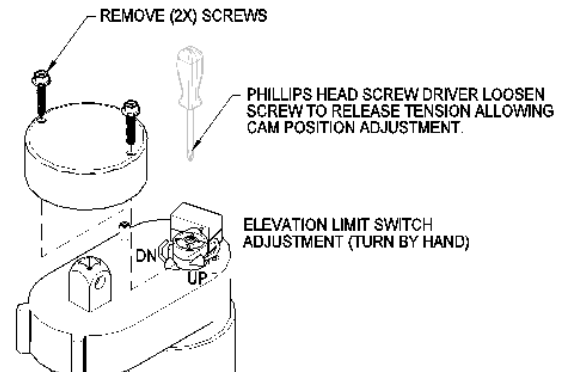

## TMX428CP & TMX58 PARAMETER SCREEN

To gain access to the parameter screen hold down on QUICK SPEED **4** for approximately 4 seconds.

### Parameter screen description:

- P02 Stop History
- P05 Maximum Speed Setting
- P09 Accurate Speed B (External Sensor)
- P10 Firmware version (Lower Board)
- P14 Accurate Speed A (Motor Controller)
- P15-P20 Elevation Calibration Points
- P22 Run Time
- P30 Calibration Fail Code (0=Calibrated)
- C00 Setting = 1 Quick Speed Enabled  
Setting = 3 Quick Speed Disable
- C01 Minimum Start Speed 0.0 to 1.0 MPH
- C02 Maximum Elevation
- SPD Manual Control Speed Any +or- Key
- ELE Manual Control Elevation Any +or- Key

TMX428 VERSION 0.4C							
ENTER: NEXT		PROG: PREV		+- EDIT		START: EXIT	
P00	1	P01	400000	P02	33	P03	160
P04	100	P05	150	P06	0	P07	0
P08	0	P09	0	P10	135	P11	1000
P12	25	P13	14925	P14	0	P15	19
P16	96	P17	198	P18	305	P19	400
P20	495	P21	990	P22	11	P23	35
P24	0	P25	160	P26	342	P27	1000
P28	1000	P29	7615	P30	0	P31	0
P32	0	P33	4000	P34	0	P35	5
P36	7	P37	4753			C00	1
C01	0.1	C02	25.0	SPD	0.0	ELE	0.0

**NOTE:** Do not alter any parameter values with Consulting the factory. Altering the parameters may cause the treadmill to malfunction.

## TMX428CP & TMX58 STOP HISTORY

To view history highlight the P2 parameter and hold down on the QUICK SPEED 2 for approximately 5 seconds.

Using the + or – key, this allows you to highlight a specific stop code and receive a brief description for stopping (Example 34 is NORMAL STOP).

- Start Rejected (8 or 40)
- Stop due to kill switch open (16 or 48)
- Motor Controller Fault (64 or 96)
- Overspeed Motor Controller (128 or 160)
- Overspeed External Speed Sensor (256 or 288)
- Speed Delta Error (512 or 544)
- Set Speed to Zero Command (1024 or 1056)
- Auto Stop Command (2048 or 2080)
- Measured Zero Speed Error (8224)

STOP HISTORY (00=MOST RECENT)							
+- SELECT				COOL DOWN:EXIT			
#00	34	#01	544	#02	34	#03	34
#04	34	#05	34	#06	34	#07	34
#08	34	#09	34	#10	34	#11	34
#12	34	#13	34	#14	34	#15	34
#16	34	#17	34	#18	34	#19	34
<b>NORMAL STOP</b>							

## Firmware Download FGLF0495-1 (3<sup>rd</sup> Edition Smart Power Supply)

1. Copy the FVProg.ROM to a Micro SD card (consult factory for the correct firmware version).
2. Locate the main power switch and set the switch in the off position.
3. Remove the motor pan hood screw to gain access to the Smart Power supply circuit board.
4. Insert the SD card into the SD card reader slot as shown at right.
5. Switch the main power switch to the ON position. Be sure to keep hands away from electrical components which may cause a shock hazard.
6. There is a LED at D13 that will flash at a slow rate of 0.5 seconds per flash while the system is searching for the SD card and reprogramming the processor.
7. Once the program is loaded, the LED should light solid. The down relay will also turn on to initialize the system. The D13 will flash once per second; this requires a speed calibration before returning to service.

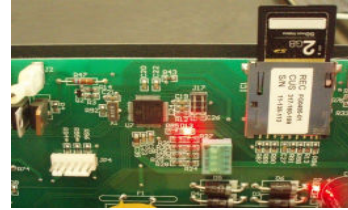

## Firmware Download FGLF0495-3 (4<sup>th</sup> Edition Smart Power Supply)

1. Copy the FVProg18.ROM to a Mini Micro SD card (consult factory for the correct firmware version).
2. Locate the main power switch and set the switch in the off position.
3. Remove the motor pan hood screw to gain access to the Smart Power supply circuit board.
4. Insert the SD card into the SD card reader slot as shown at right.
5. Switch the main power switch to the ON position. Be sure to keep hands away from electrical components which may cause a shock hazard.
6. There is a LED at D13 that will flash at a slow rate of 0.5 seconds per flash while the system is searching for the SD card and reprogramming the processor.
7. Once the program is loaded, the LED should light solid. The down relay will also turn on to initialize the system. The D13 will flash once per second; this requires a speed calibration before returning to service.

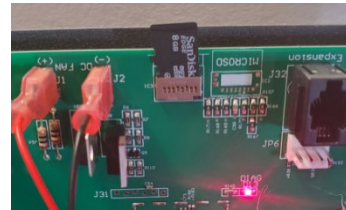

## Firmware Download FGLF0496 (3<sup>rd</sup> Edition LCD Control)

1. Copy the THORCONS.ROM to a Micro SD card (consult factory for the correct firmware version).
2. Locate the main power switch and set the switch in the off position.
3. Remove the upper plastic console screws (10X) to gain access to the LCD Screen circuit board.
4. Insert the Micro SD card into the SD card reader slot as shown at right.
5. Switch the main power switch to the ON position. Be sure to keep hands away from electrical components which may cause a shock hazard.
6. There is a LED at LED1 that will flash at a slow rate of 0.5 seconds per flash while the system is searching for the SD card and reprogramming the processor. During the download process the LCD screen will remain black until the new firmware has been fully loaded.
7. Once the program is loaded, the LED should rapidly flash. The blue screen will display the Welcome Screen.



## Firmware Download FGLF0698-00 (4<sup>th</sup> Edition LCD Control)

1. Copy the Console.ROM to a Mini Micro SD card (consult factory for the correct firmware version).
2. Locate the main power switch and set the switch in the off position.
3. Remove the upper plastic console screws (10X) to gain access to the LCD Screen circuit board.
4. Insert the SD card in to the SD card reader slot as shown at right.
5. Switch the main power switch to the ON position. Be sure to keep hands away from electrical components which may cause a shock hazard.
6. There is a LED at LED1 that will flash at a slow rate of 0.5 seconds per flash while the system is searching for the SD card and reprogramming the processor. During the download process the LCD screen will remain black until the new firmware has been fully loaded.
7. Once the program is loaded, the LED should rapidly flash. The blue screen will display the Welcome Screen.



## Dip Switch Configuration

Position Dip Switch 1: In the “OFF” position, units are set to English “MPH”. In the “ON” position, units are set to Metric “KPH”.

Position Dip Switch 2: In the “OFF” position, a communication disconnect stop timeout is 2.5 seconds. In the “ON” position, the communication disconnect stop timeout is extended to 4 seconds.

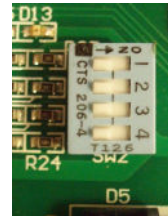

Position Dip Switch 3 (Firmware Version 1.43 & later FGLF0495-1 Smart Power Supply): When in the “OFF” position for Trackmaster Interface Protocol, in the “ON” position New Customer Interface Protocol.

Position Dip Switch 4: In the “OFF”, for factory use only.

Additional dip switch (Firmware Version 1.1812 and later FGLF-4953-03 Smart Power Supply). This configuration has 1-6 number switches, position 1 thru 4 are same as (FGLF0495-1 Smart Power Supply).

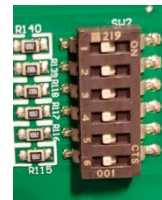

Position dip switch 5 (Firmware Version 1.1812 and later FGLF-4953-03 Smart Power Supply) stores the ability to retrieve trouble shooting log file. When retrieving system flash log file switch configuration 1,2,3,4, and 6 are in the “OFF” position and switch 5 is in the “ON” position.

Position dip switch 6 unassigned (Firmware Version 1.1812 and later FGLF-4953-03 Smart Power Supply).

## Log File Retrieval FGLF0495-3 (4<sup>th</sup> Edition Smart Power Supply)

1. Turn Power Switch to the “OFF” position on the treadmill.
2. Remove the motor pan hood screws to gain access to the Smart Power supply circuit board.
3. Insert a blank Mini Micro SD card into IC3 card reader slot.
4. Record the position of the switch configuration.
5. Set switch configuration 1,2,3,4 and 6 are in the “OFF” position and switch 5 is in the “ON” position.
6. Switch the main power switch to the ON position. Be sure to keep hands away from electrical components, which may cause a shock hazard. Depending on the number of records to be written, it can take up to 5 minutes to finish. When complete the treadmill begins power initialization sequence.
7. Once the program is loaded, the D13 LED light should light solid.
8. Turn Power Switch to the “OFF” position on the treadmill and retrieve the Mini Micro SD card.
9. Reset the switch configuration to the previous position (Step 4).
10. Cycle the Power Switch.
11. Provide the downloaded log file “FVFLASH.BIN” for content review.
12. Contact Trackmaster Service.
- 13.

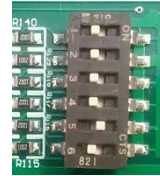
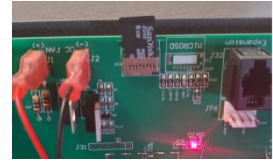

# Parts List with Part Numbers

## Motor Mount Assembly (Kollmorgen)

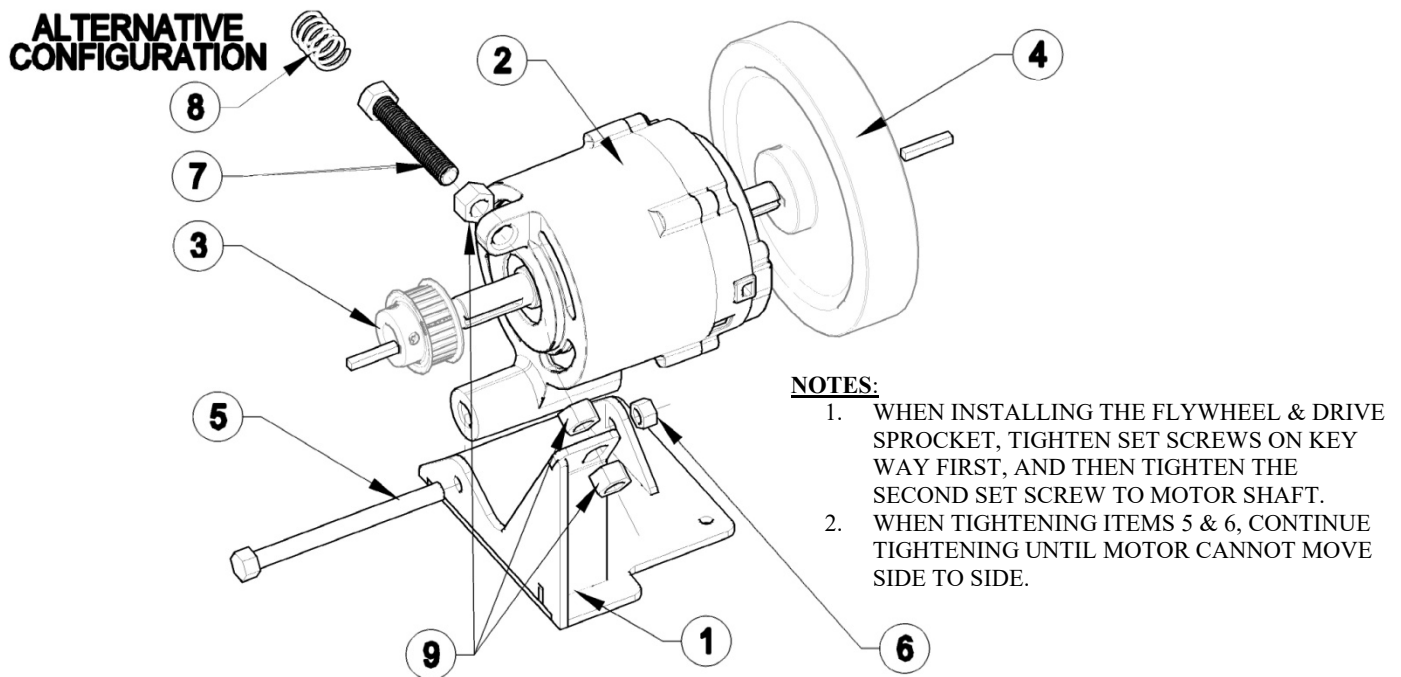

Item	Description	Part Number	Qty
1	DC Motor Base	317-701-001	1
2	Motor DC Servo PMCFA-00101-03	317-160-197	1
3	Sprocket Drive 530-5MGT-15	317-160-201	1
4	Flywheel DC W/Magnet .50 dia	317-160-200	1
5	HHCS 7/16-14 x 5" LG	001-2332	1
6	NLN 7/16-14	001-2333	1
7	HHCS 1/2-13 3" LG All Thread HHCS 1/2-13 5" LG All Thread (Alternative)	001-2348 001-2331	1
8	Spring Motor Tension (Alternative)	317-160-218	1
9	HN 1/2-13 GR5	001-1390	3

## Motor Mount Assembly 317-759-001S (TruTech)

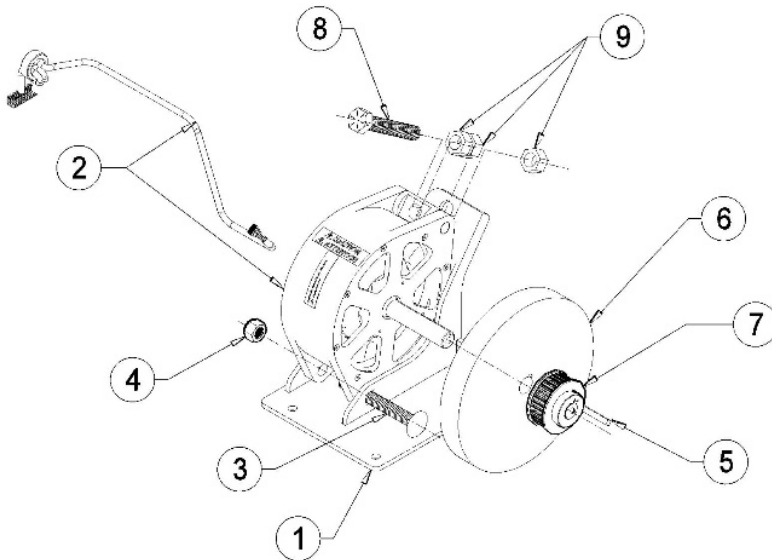

### NOTES:

1. WHEN INSTALLING THE FLYWHEEL & DRIVE SPROCKET, TIGHTEN SET SCREWS ON KEY WAY FIRST, AND THEN TIGHTEN THE SECOND SET SCREW TO MOTOR SHAFT.
2. WHEN TIGHTENING ITEMS 5 & 6, CONTINUE TIGHTENING UNTIL MOTOR CANNOT MOVE SIDE TO SIDE.

Item	Description	Part Number	Qty
1-9	Motor Bracket TruTech (Orderable Service Part)	317-759-001S	1

Item	Description	Qty
1	Motor Bracket TruTech	1
2	Motor-TruTech 53-0481	1
3	CB-7/16-14 X 3.50 GR2 – Clear Zink	1
4	NLN 7/16-14	1
5	Motor Key .188 X .188 X 2.0	1
6	Flywheel TruTech	1
7	Sprocket Drive 9-30-5MGT-15 .625 BORE	1
8	HHCS- 1/2-13 X 3.00 Gr 5 Full Thread – Clear Zink	1
9	HN- 1/2-13 Gr – Clear Zinc Plt	3

### 3<sup>rd</sup> Edition Circuit Board Assembly

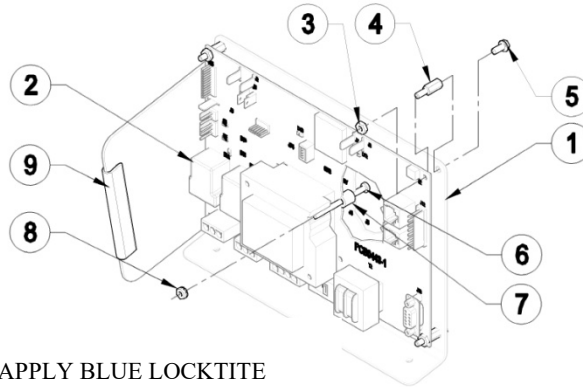

**NOTES:**  
 APPLY BLUE LOCKTITE  
 THREADLOCKER TO ITEM 8

Item	Description	Part Number	Qty
1	Bracket Circuit Board	317-709-001	1
2	Board FG0495-0 Universal Power Supply	317-160-199	1
3	HN #8-32 Nylon	001-1763	4
4	Mount Inverter Isolation	317-160-040	4
5	HHWHTS #8-32 x .375	001-1744	4
6	RHMS #6-32 x 2.5" LG	001-1890	1
7	Standoff Round .50 LG .166 ID	001-1854	1
8	K-Lock Nut #6-32	001-1858	1
9	Trim Black 3" LG	001-102-044	1

### 3<sup>rd</sup> Edition Final Assembly Circuit Board Connection

CONNECT HARNESS TO PATIENT  
 SAFETY TETHER (LEADS J7 & J6)

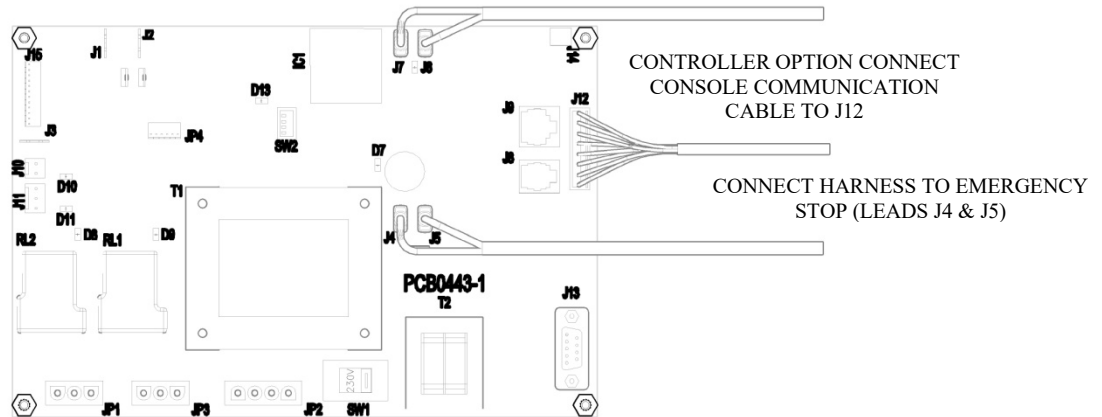

### 4<sup>th</sup> Edition Circuit Board Assembly

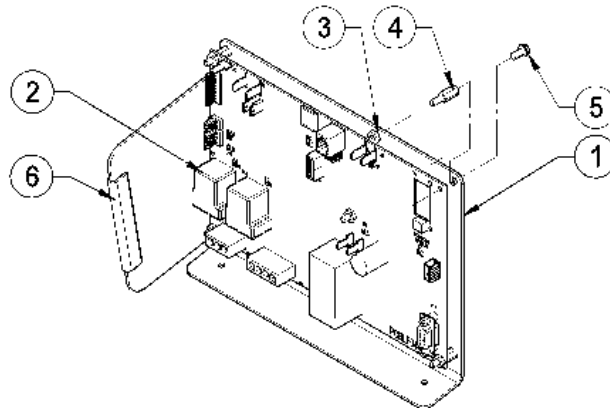

Item	Description	Part Number	Qty
1	BOARD FG0495-3 UNIVERSAL PWER SUPPLY	317-160-199S	1

**For Reference – Manufacture’s Description for individual items**

Item	Description	Qty
1	Bracket Circuit Board	1
2	Board FG0495-3 Universal Power Supply	1
3	HN #8-32 Nylon	5
4	Mount Inverter Isolation	5
5	HHWHTS #8-32 x .375	5
6	Trim Black 3” LG	1

### 4<sup>th</sup> Edition Final Assembly Circuit Board Connection

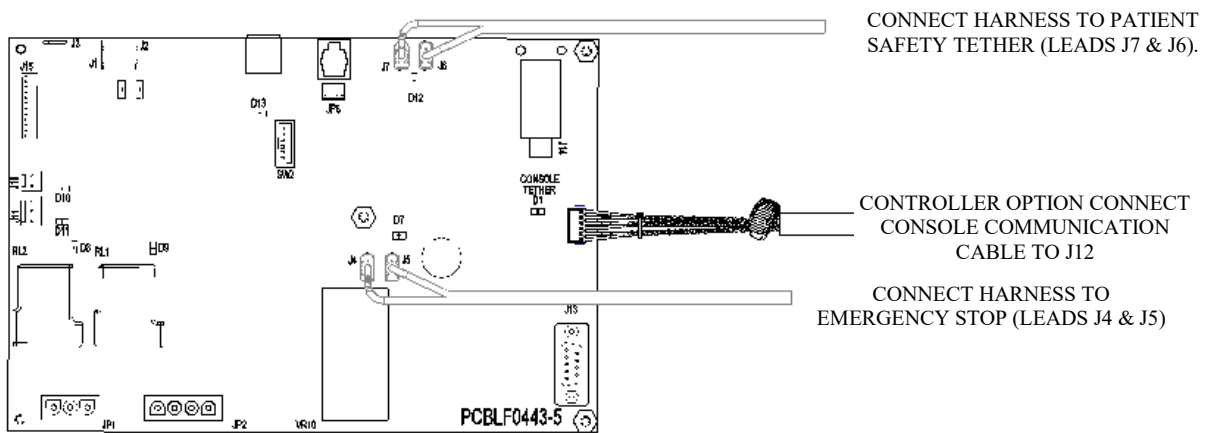

### Quantum Drive Assembly 317-761-001S

NOTICE: WILL NOT WORK WITH CONTROL PANEL MODELS

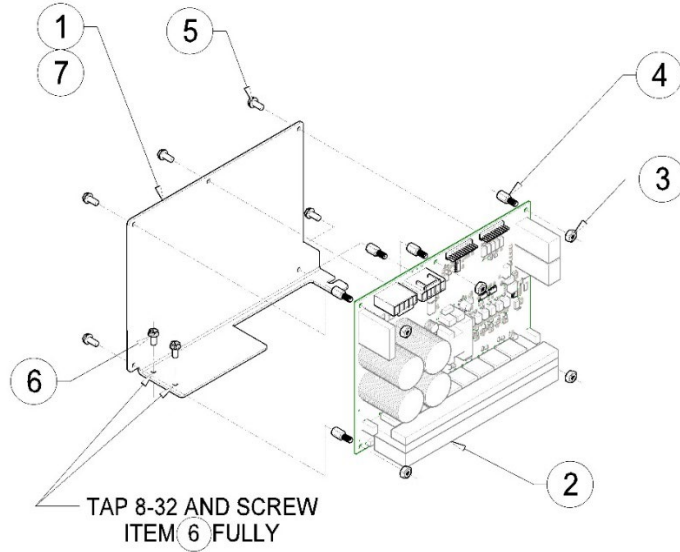

Item	Description	Part Number	Qty
1	DRIVE ASSEMBLY QUANTUM	317-761-001S	1

#### For Reference – Manufacture’s Description for individual items

Item	Description	Qty
1	Drive Bracket Quantum	1
2	Drive – Quantum 800—0011470R01	1
3	HN- #8-32 X .50 GR 2 – Clear Zinc Plt	2
4	Mount – Invertor Isolation	5
5	HHWHTS- #8-32 X .375	5
6	HHCS- #8-32 Nylon (Only)	5
7	Decal PCB Quantum Control	1

## Quantum Drive Assembly 317-995-001S

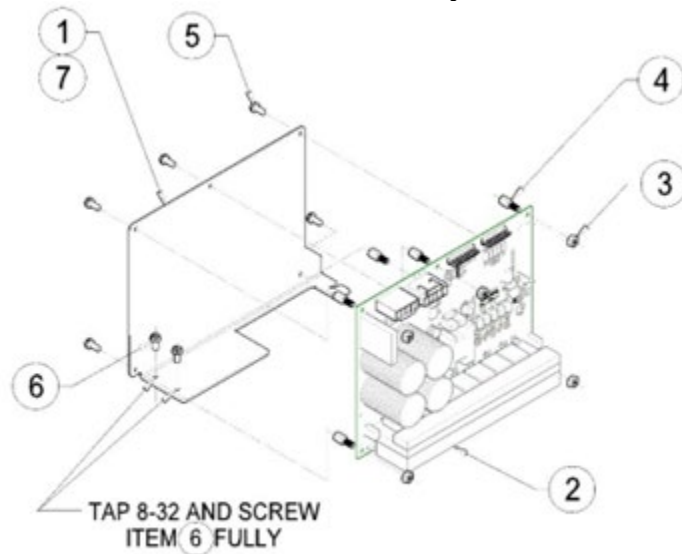

### NOTICE:

Item	Description	Part Number	Qty
1	DRIVE ASSEMBLY QUANTUM	317-995-001S	1

### For Reference – Manufacture’s Description for individual items

Item	Description	Qty
1	Drive Bracket Quantum	1
2	Drive – Quantum 800-00112620R0A	1
3	HN- #8-32 X .50 GR 2 – Clear Zinc Plt	2
4	Mount – Invertor Isolation	5
5	HHWHTS- #8-32 X .375	5
6	HHCS- #8-32 Nylon (Only)	5
7	Decal PCB Quantum Control	1

## Elevation Assembly

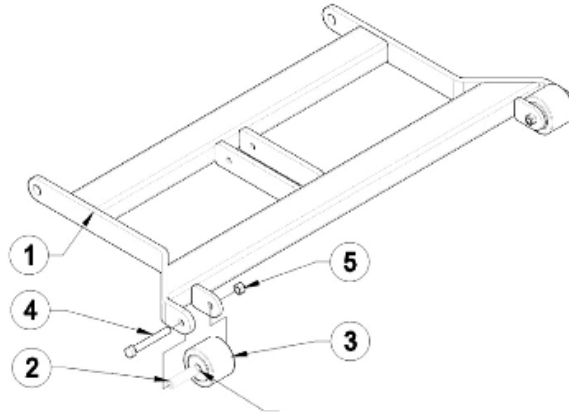

APPLY TRACKMASTER GREASE 2X PN# (317-160-165)

Item	Description	Part Number	Qty
1	Elevation Weldment TMX428	317-702-002	1
2	Spanner Wheel	317-160-054	2
3	Wheel Landing Gear	317-160-005	2
4	HHCS 3/8-16 x 3.25 LG GR5	001-1519	2
5	NLN 3/8-16	001-1430	2

## Patient Safety Tether Assembly

**NOTE:** There are two approved styles of the Patient Safety Tether Switches

1. Pull Tether Clip
2. Magnetic Tether

### Pull Tether Clip Assembly

**NOTE:**

The pull tether clip needs to be seated for the treadmill to operate as designed.

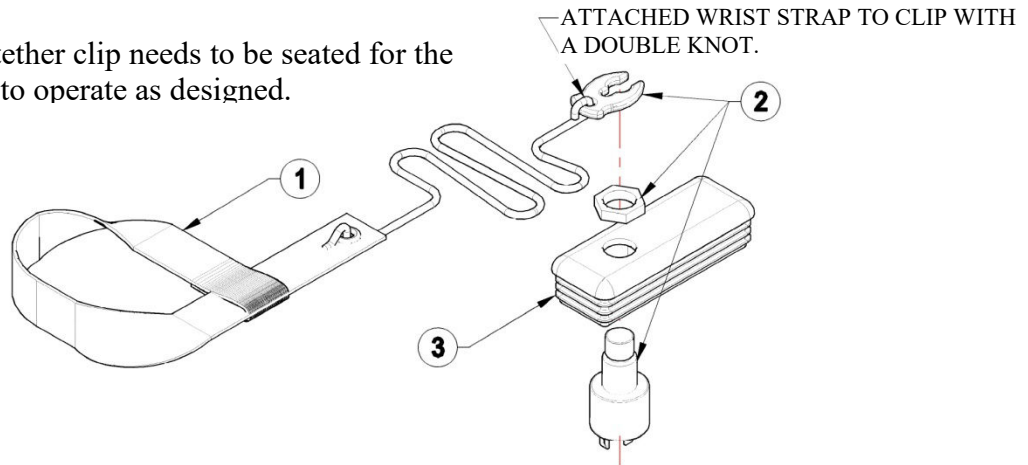

Item	Description	Part Number	Qty
1	Tether Pull w/Wrist strap (Not Sold Individually)	317-160-229	1
2	E-Stop Kill Switch LS500 (Not Sold Individually)	317-160-226	1
3	Cap 1.50 x 4.00 LPDE BLK Modified (Not Sold Individually)	317-160-230	1
1-3	Pull Tether Assembly (Sold as Assembled Kit)	317-720-001	1

## Magnetic Tether Assembly

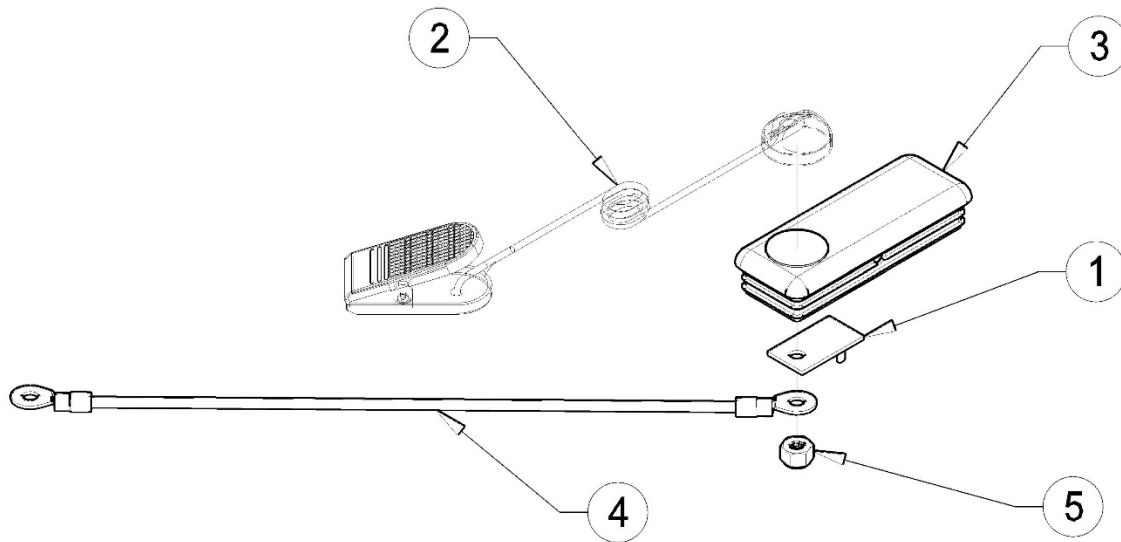

Item	Description	Part Number	Qty
1	BOARD PCB TETHER	317-160-441	1
2	TETHER-CLIP MAGNET (Can be ordered Separately)	317-160-447	1
3	Cap 1.50 x 4.00 LPDE BLK ELEVATOR BOLT	317-160-448	1
4	GROUND CABLE PCB TETHER	317-160-449	1
5	NLN- 1/4-20	001-1427	1
1-5	Magnetic Tether Assembly (Sold as Assembled Kit)	317-764-001	1

## Emergency Stop Assemblies

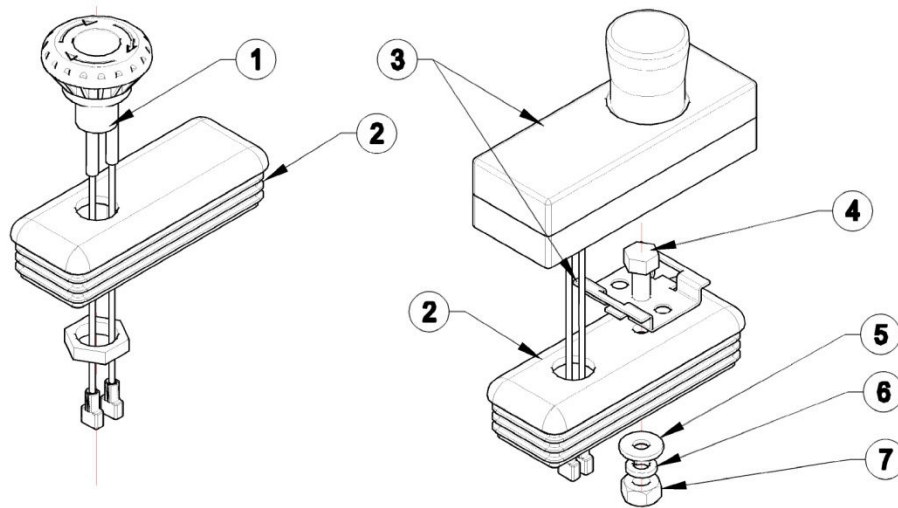

Item	Description	Part Number	Qty
1	Emergency Stop IDEC (Not Sold Individually)	317-160-268	1
2	Cap 1.50 x 4.00 LPDE BLK Modified (Not Sold Individually)	317-160-230	1
1-2	Emergency Stop Assembly (Sold as Assembled Kit)	317-722-001	1
3	Emergency Stop RAFI (Alternative E-Stop)	317-160-212	1
4	Bolt HHCS 1/4-20 x 3/4" LG GR 5	001-1186	1
5	Flat Washer 1/4"	001-1439	1
6	Lock Washer 1/4"	001-1450	1
7	Nut HN 1/4-20 GR 5	001-1386	1

# Motor Pan Assembly (Kollmorgan)

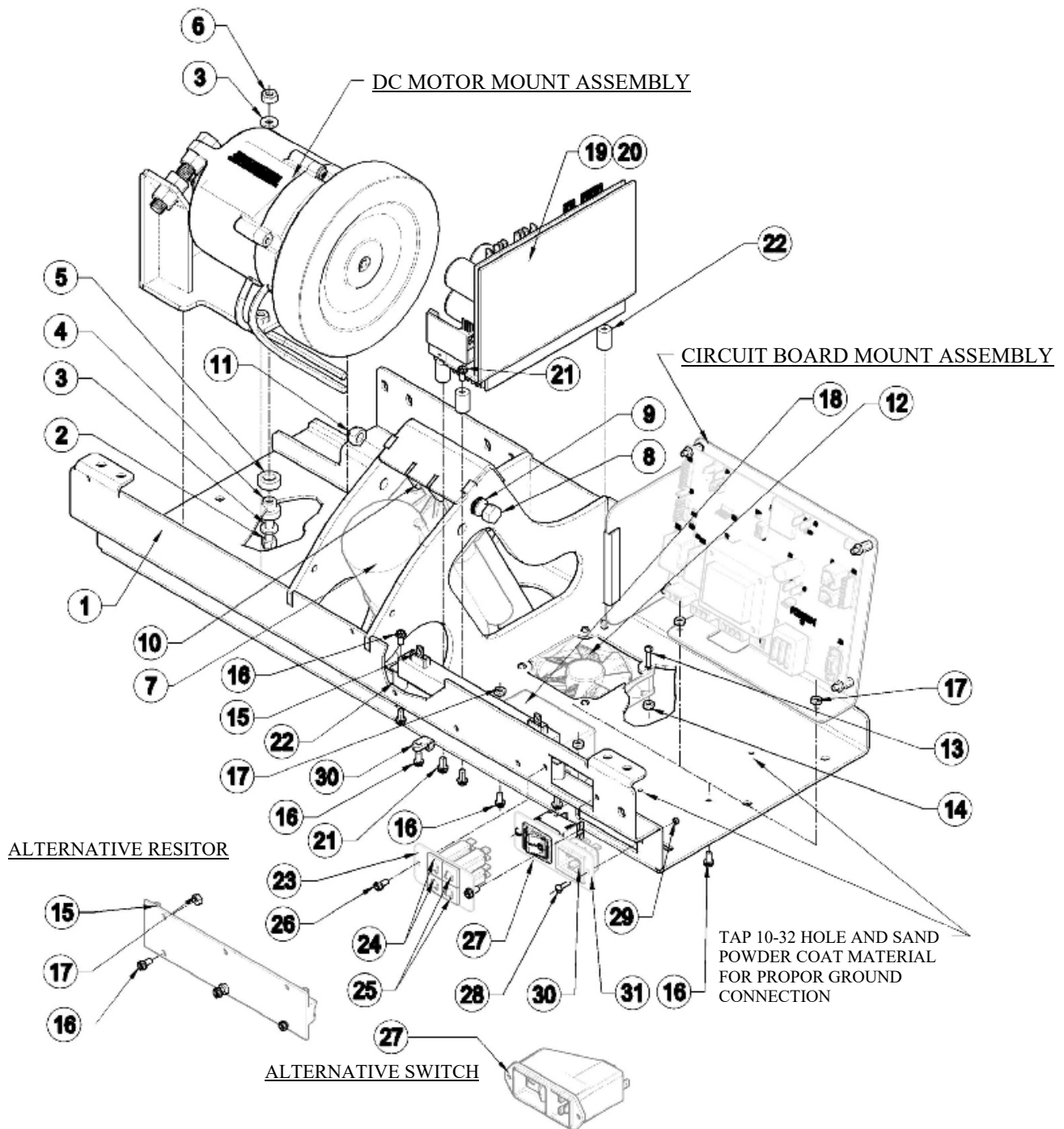

**Motor Pan Assembly (Kollmorgan) continued**

<b>Item</b>	<b>Description</b>	<b>Part Number</b>	<b>Qty</b>
1	Motor Pan Weldment	317-700-001	1
2	HHCS ¼-20 x 1.25 LG GR 2	001-1159	4
3	FW ¼” Dia (Above)	001-1439	4
	Fender Washer ¼” Dia 1” OD (Bellow)	001-1888	4
4	Motor Isolation Stem	317-160-216	4
5	Motor Isolation Spacer	317-160-217	4
6	NLN 1/4-20	001-1427	4
7	Actuator 115V	317-160-090	1
	Actuator 220V	317-160-029	
8	HHCS 3/8-16 c 5.0” LG GR 5	001-1743	1
9	FW 3/8” Dia	001-1441	3
10	Washer Nylon	317-160-086	3
11	NLN 3/8-16	001-1430	1
12	Fan Assembly DC W/Connector	317-160-202	1
13	RHMS #6-32 x .50” LG	001-1851	4
14	K-Lock Nut #6-32	001-1858	4
15	Resistor Omite 85/150MJ40R0DE	317-160-233	1
	Alternative Resistor Omite		
16	HNS #8-32 Flange	001-1636	7
17	HHWHTS #8-32 X .50” LG	001-1764	7
18	Filter CorCom F4635	317-160-240	1
19	Drive DC Servo PC2303-012-N	317-160-196	1
20	Regen Module RA2302		
21	RHMS #10-32 X .375 LG	001-1755	6
22	NYLON ISOLATOR #10-32	317-160-259	5
23	Plate Breaker Trackmaster	317-710-001	1
24	Breaker 3 Amp	317-160-220	2
25	Breaker 1/4 Amp	317-160-024	2
26	HHWHTS #8-32 x .375” LG	001-1744	2
27	Switch TA35-C324-L200C0	317-160-256	1
	Alternative Switch “Schurter Power Entry Module”	317-160-139	
28	RHMS #6-32 x .50” LG	001-1851	2
29	K-Lock Nut #6-32	001-1858	2
30	POWER CORD INLET C-20 4793.4000	317-160-257	1
31	PLATE SWITCH TMX428	317-718-001	1

# Motor Pan Assembly Wiring (Kollmorgan)

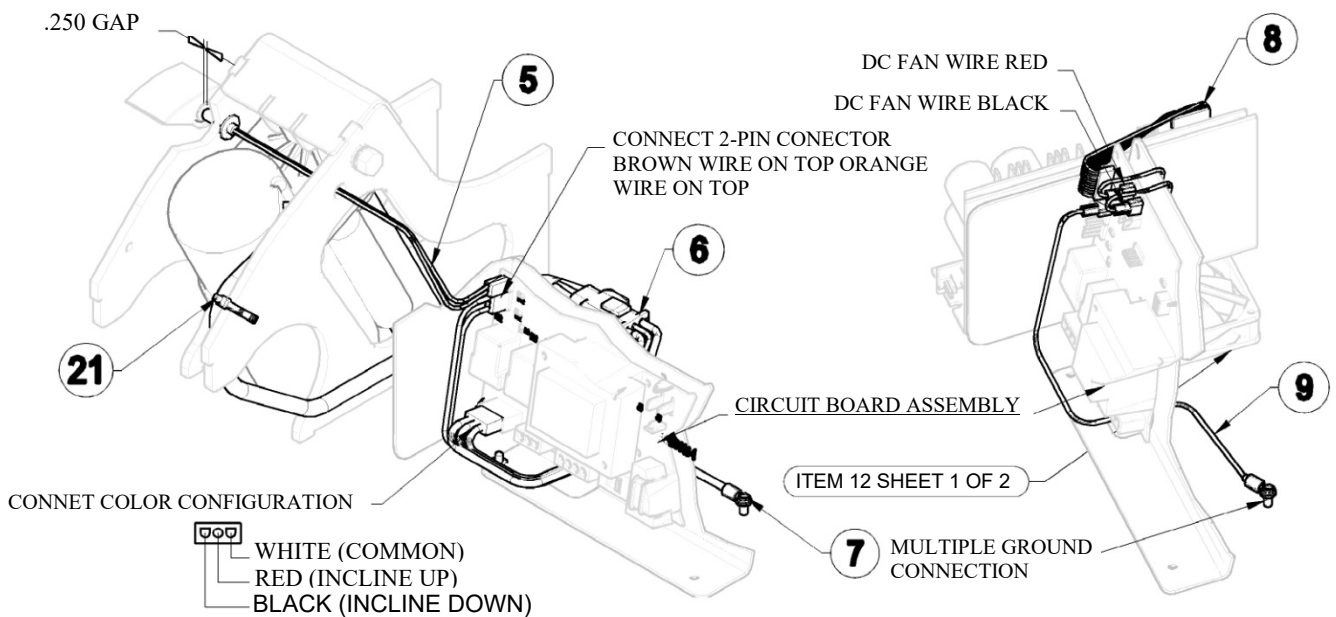
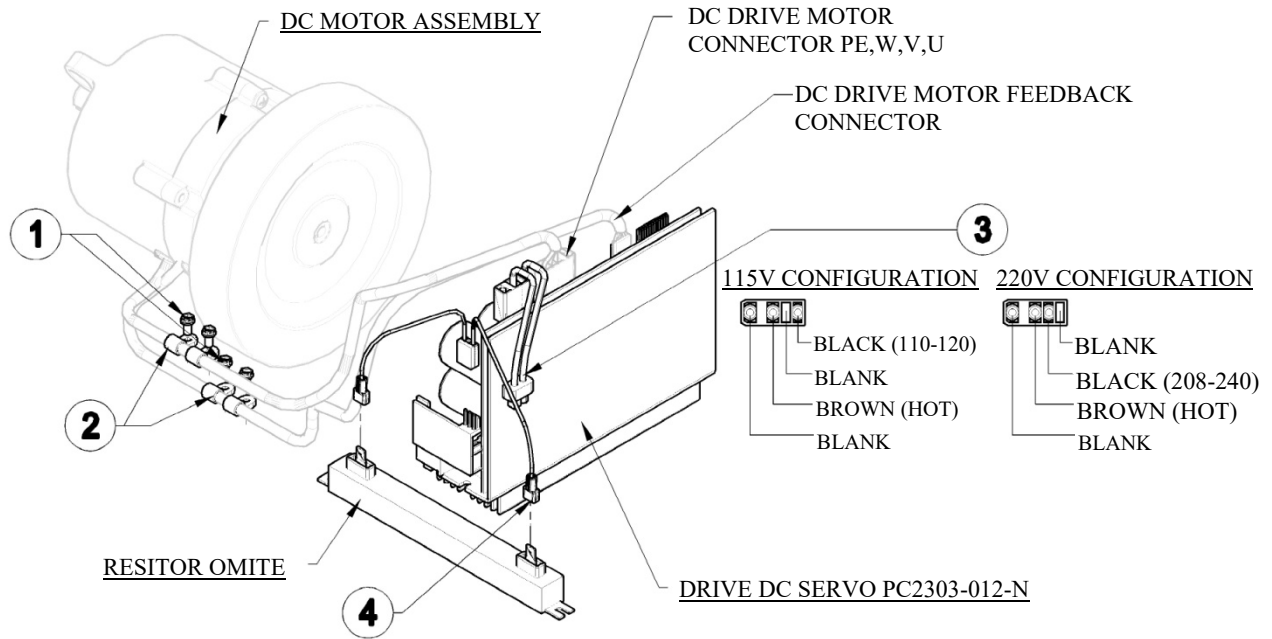

# Motor Pan Assembly Wiring (Kollmorgan) continued

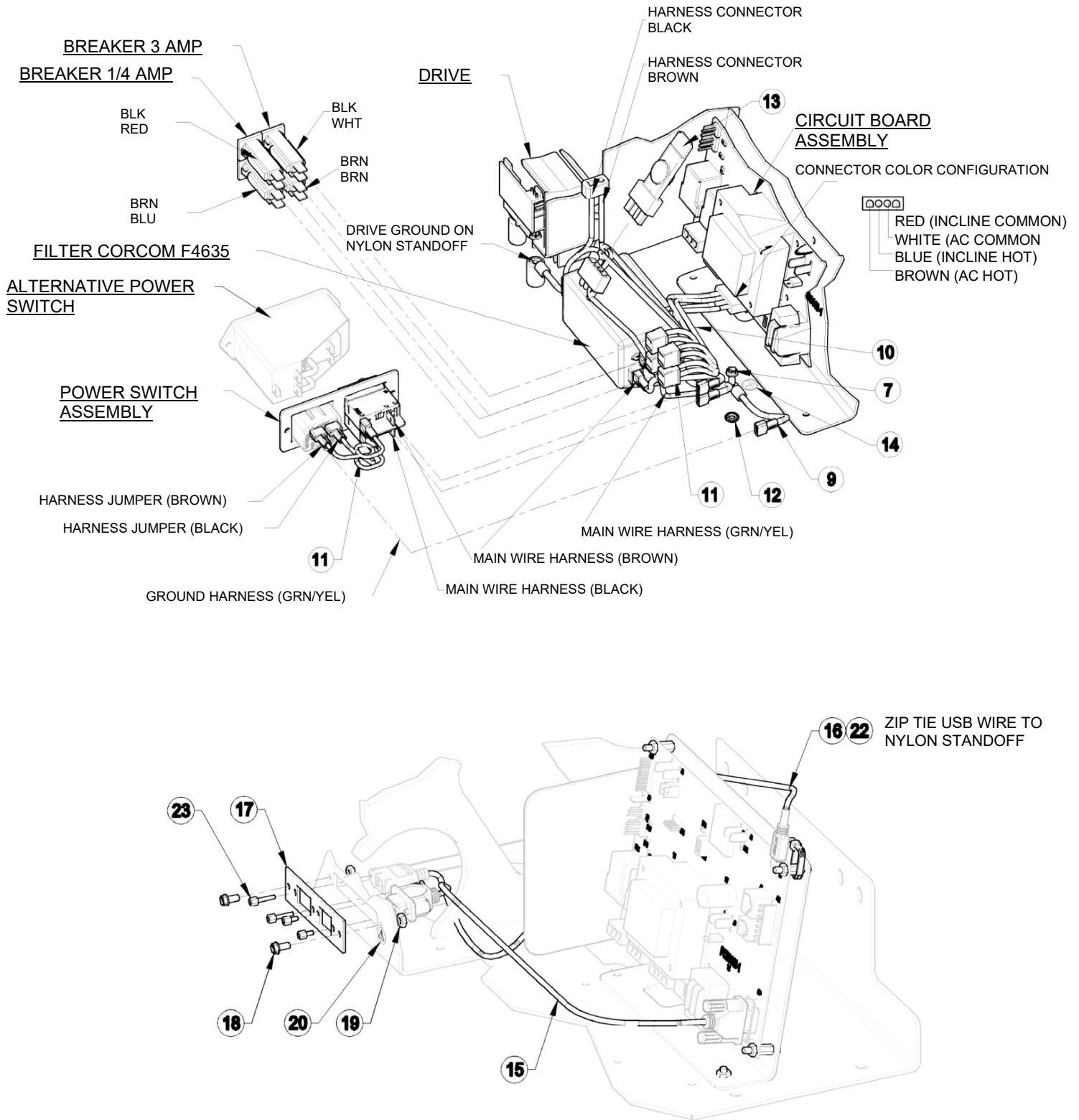

**Motor Pan Assembly Wiring (Kollmorgan) continued**

<b>Item</b>	<b>Description</b>	<b>Part Number</b>	<b>Qty</b>
1	Screw HHWTS #8-32 x .375 LG	001-1744	4
2	Clamp Plastic 1/4" ID	317-160-227	4
3	Harness 110V DC Treadmill Harness 220V DC Treadmill	317-160-261 317-160-262	1
4	Harness Resistor	417-160-026	1
5	Speed Sensor Hall Effect Harness Speed Sensor	317-160-305 317-160-306	1 1
6	Harness Elevation	317-160-231	1
7	HH Screw #10-32 x .375 LG GRD	317-160-076	2
8	Harness Motor Controller	317-160-208	1
9	Harness Ground	317-160-070	2
10	Harness Main DC Treadmill	317-160-247	1
11	Harness Jumper	317-160-071	2
12	LW #10 EXT Tooth	001-1751	1
13	Surge Suppressor	317-160-129	1
14	Decal Ground	317-160-273	1
15	Cable RS232 Panel Mount	317-160-236	1
16	Cable USB Panel to USB B	317-160-237	1
17	Plate RS232 & USB	317-160-254	1
18	HHCS #8-32 x .50 LG	001-1764	2
19	HNS #8-32 Flange Nut	001-1636	2
20	Decal Caution	317-160-274	2
21	Zip Tie 8" LG	317-160-280	1
22	Zip Tie 4" LG	317-160-075	1
23	RMHS #4-40 x .375 LG	001-2360	2

# Motor Pan Assembly (TruTech)

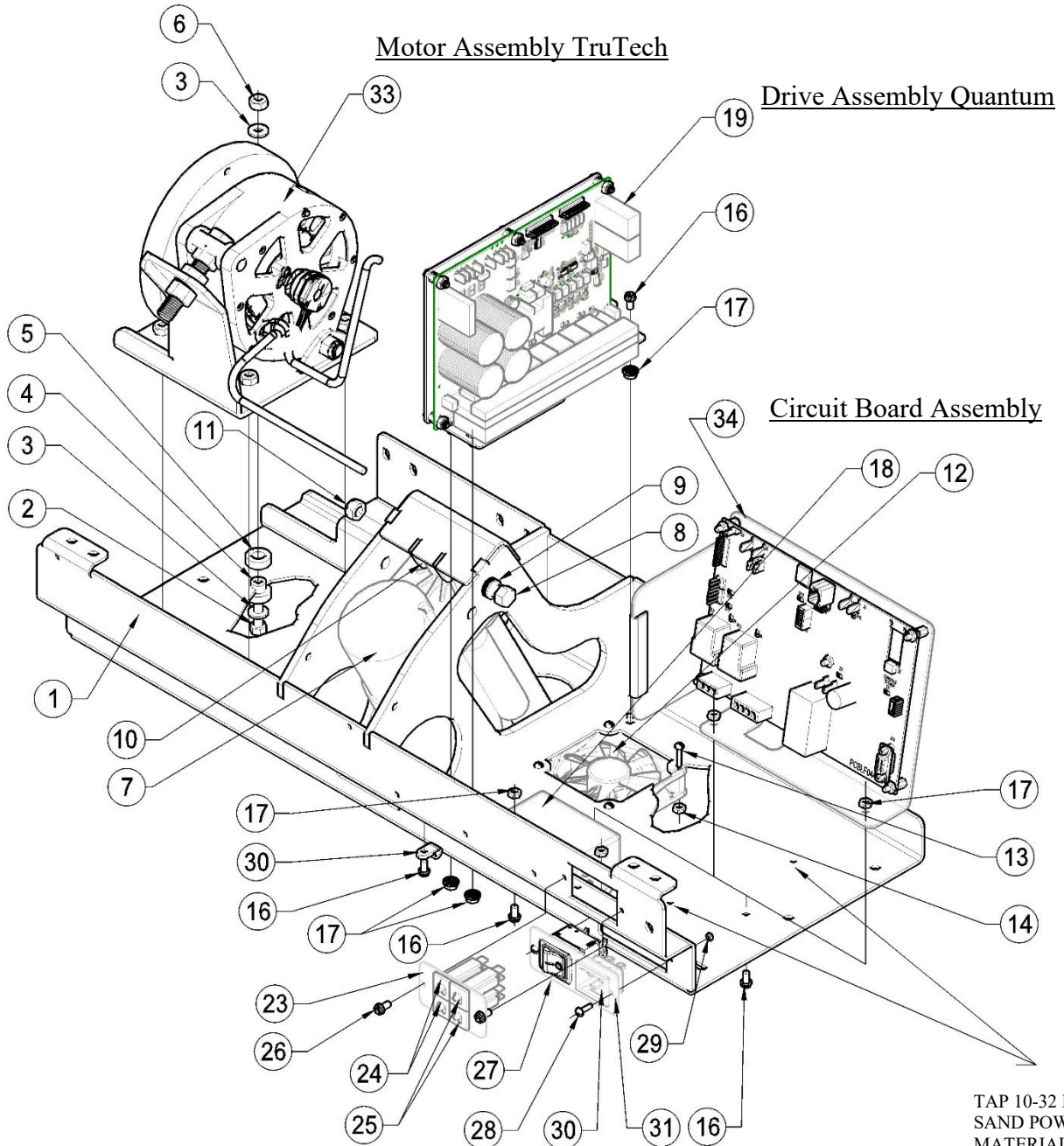

**Motor Pan Assembly (TruTech) continued**

<b>Item</b>	<b>Description</b>	<b>Part Number</b>	<b>Qty</b>
1	Motor Pan Weldment	317-700-001	1
2	HHCS 1/4-20 x 1.25 LG GR 2	001-1159	4
3	FW 1/4" Dia	001-1439	4
4	Motor Isolation Stem	317-160-216	4
5	Motor Isolation Spacer	317-160-217	4
6	NLN 1/4-20	001-1427	4
7	Actuator 115V Actuator 220V	317-160-090 317-160-029	1
8	HHCS 3/8-16 X 5.0 GR 5	001-1743	1
9	FW 3/8" Dia	001-1441	3
10	Washer Nylon	317-160-086	3
11	NLN 3/8-16	001-1430	1
12	Fan Assembly DC W/Connector	317-160-202	1
13	RHMS #6-32 x .50 LG	001-1851	4
14	K-Lock Nut #6-32	001-1858	4
15	NOT USED		
16	HHWHTS #8-32 X .50 LG	001-1764	4
17	HNS #8-32 Flange	001-1636	4
18	Filter CorCom 10EHT1	317-160-023	1
19	Drive Assembly Quantum (Sold as an Assembly)	317-761-001	1
-	Drive Assembly Quantum for Control Panel Models	317-995-001	1
20	NOT USED		
21	NOT USED		
22	NOT USED		
23	Plate Breaker Trackmaster	317-710-001	1
24	Breaker 3 Amp	317-160-220	2
25	Breaker 1/4 Amp	317-160-024	2
26	HHWHTS #8-32 x .375 LG	001-1744	3
27	Switch TA35-C324-L200C0	317-160-256	1
28	RHMS #6-32 x .50 LG	001-1851	2
29	K-Lock Nut #6-32	001-1858	2
30	POWER CORD INLET C-20	317-160-257	1
31	PLATE SWITCH TMX428	317-718-001	1
32	Clamp Plastic 1/4 ID	317-160-227	1
33	Motor Assembly TruTech	317-759-001	1
34	Circuit Board Assembly 4 <sup>th</sup> Edition	317-958-001	1
35	Fender Washer 1/4" Dia 1" OD (Bellow)	001-1888	4

# Motor Pan Assembly Wiring (TruTech)

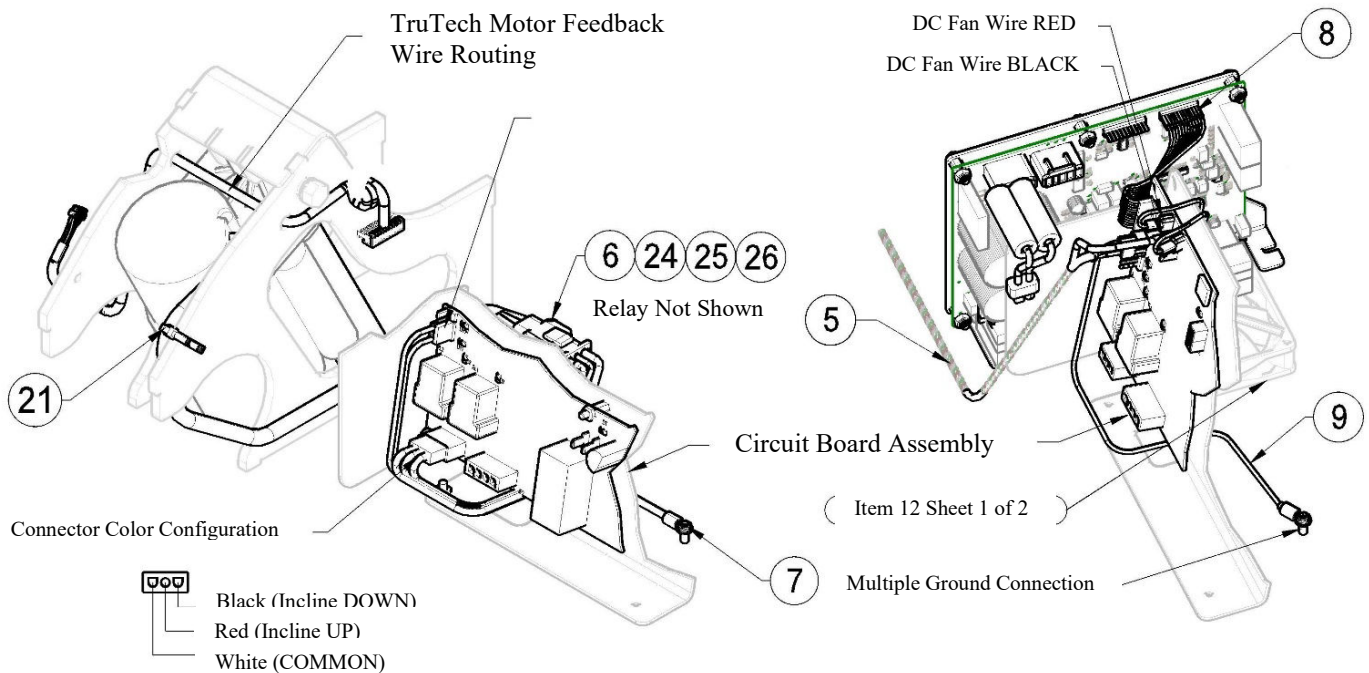
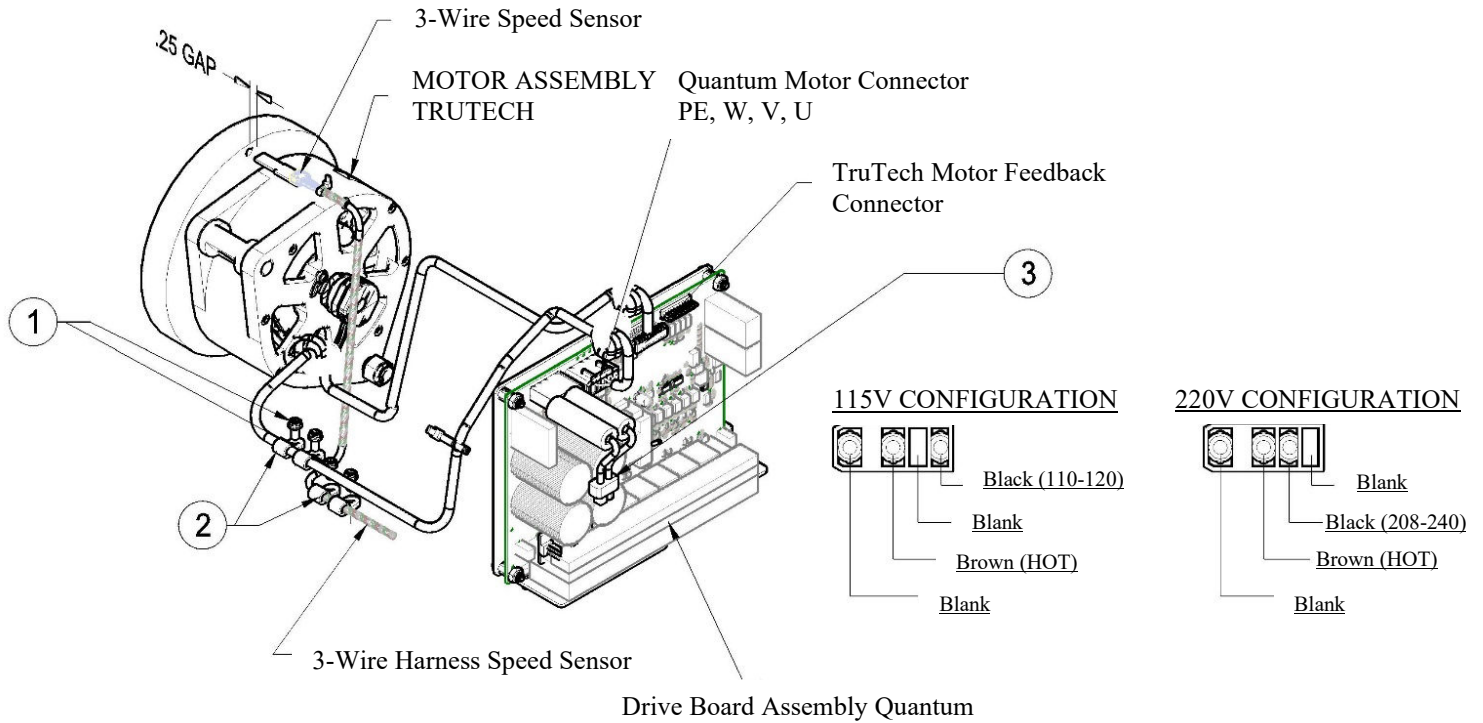

# Motor Pan Assembly Wiring (TruTech) continued

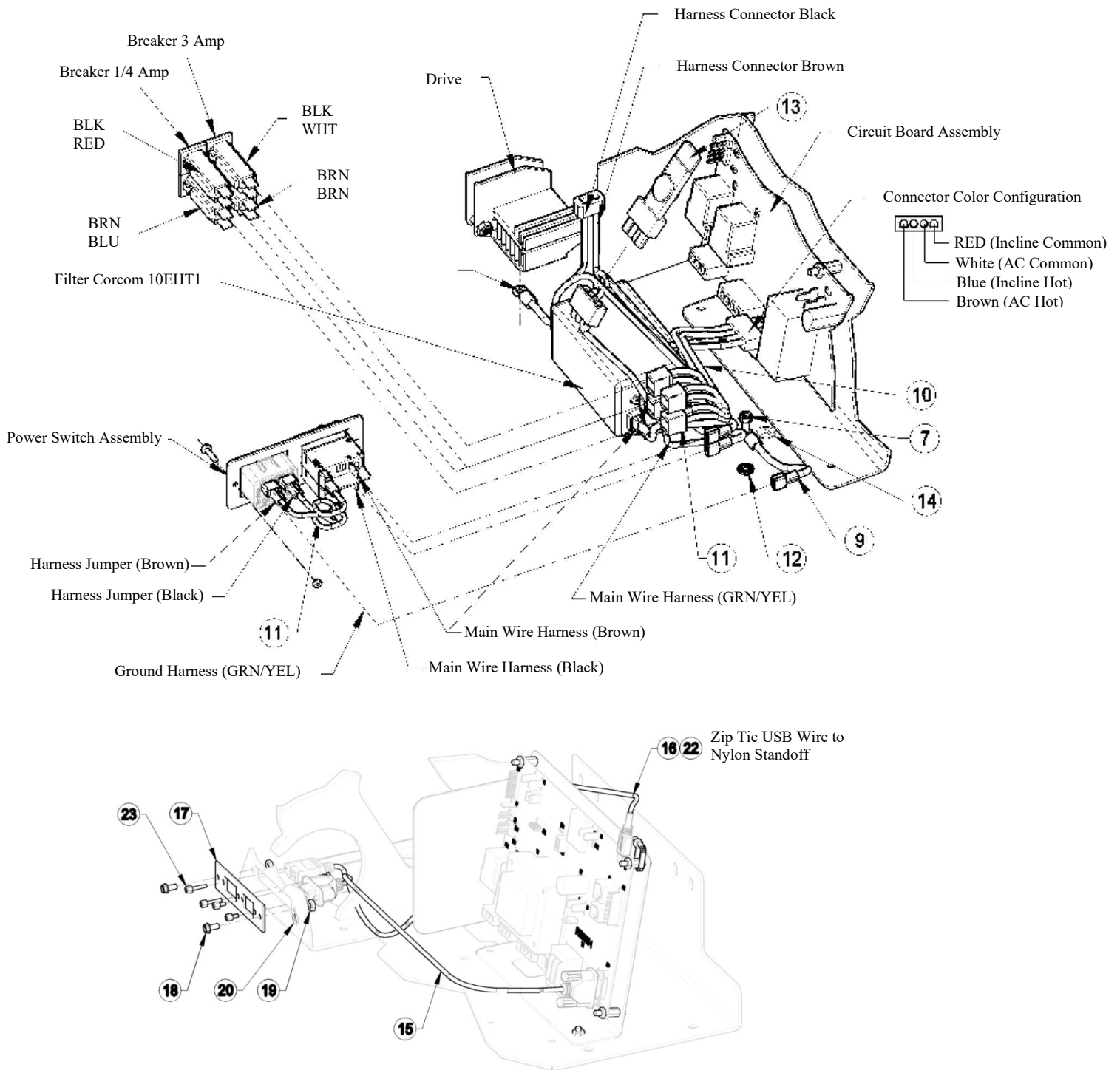

**Motor Pan Assembly Wiring (TruTech) continued**

<b>Item</b>	<b>Description</b>	<b>Part Number</b>	<b>Qty</b>
1	Screw HHWTS #8-32 x .375 LG	001-1744	4
2	Clamp Plastic 1/4" ID	317-160-227	4
3	Harness 110V DC Treadmill Harness 220V DC Treadmill	317-160-261 317-160-262	1
4	Zip Tie 4: LG – (Not Shown)	317-160-075	1
5	3-Wire Speed Sensor Hall Effect 3-Wire Harness Speed Sensor	317-160-404 317-160-405	1 1
6	Harness Elevation	317-160-231	1
7	HH Screw #10-32 x 3/8 LG GRD	317-160-076	2
8	Harness Motor Controller	417-160-031	1
9	Harness Ground	317-160-070	2
10	Harness Main DC Treadmill	317-160-247	1
11	Harness Jumper	317-160-071	2
12	LW #10 EXT Tooth	001-1751	1
13	Surge Suppressor	317-160-129	1
14	Decal Ground	317-160-273	1
15	Cable RS232 Panel Mount	317-160-236	1
16	Cable USB Panel to USB B	317-160-237	1
17	Plate RS232 & USB	317-160-254	1
18	HHCS #8-32 x .50 LG	001-1764	2
19	HNS #8-32 Flange Nut	001-1636	2
20	Decal Caution	317-160-274	2
21	Zip Tie 8" LG	317-160-280	1
22	Zip Tie 4" LG	317-160-075	1
23	RMHS #4-40 x .375 LG	001-2360	2
24	110 Relay 220 Relay	317-160-386 317-160-387	1 1
25	Velcro Hook 5/8 X 1" Long	317-160-056	1
26	Velcro Loop 5/8 X 1" Long	317-160-057	1

# Frame Assembly

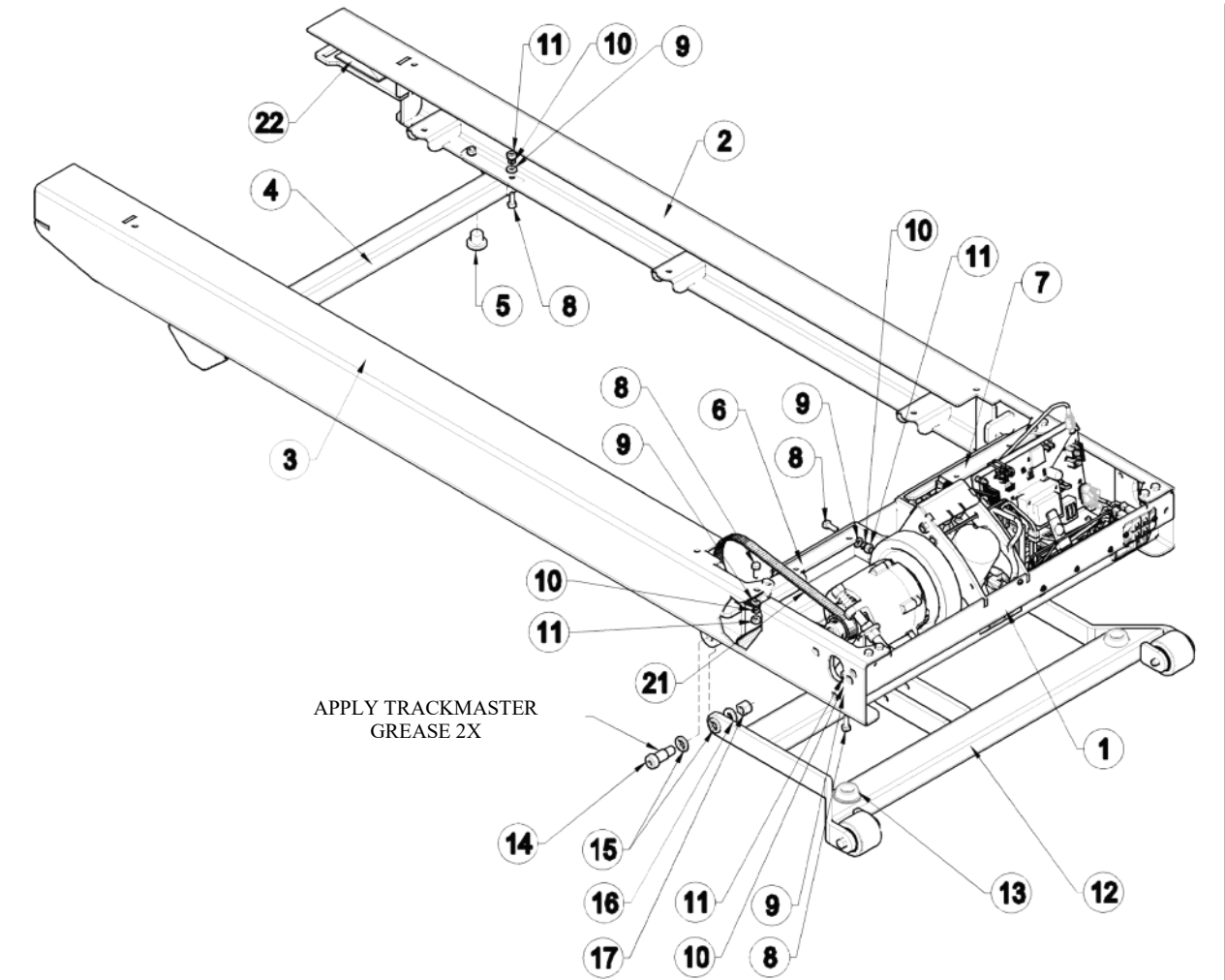

## Frame Assembly continued

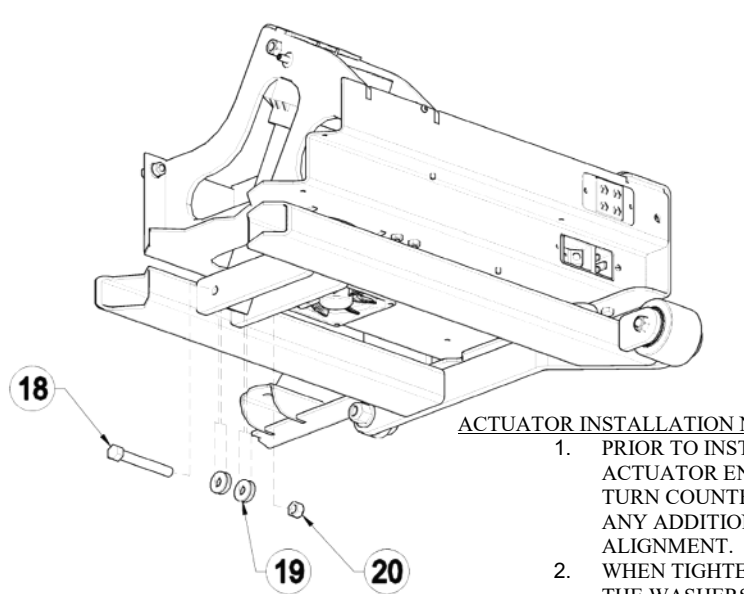

## ACTUATOR INSTALLATION NOTES:

1. PRIOR TO INSTALLATION OF BOLT, TURN ACTUATOR END CLOCKWISE UNTIL IT STOPS. NEXT TURN COUNTER CLOCKWISE 1 ½ TURN OUT PLUS ANY ADDITIONAL REVOLUTION TO ALLOW BOLT ALIGNMENT.
2. WHEN TIGHTENING ELEVATION BOLT AND NUT, THE WASHERS MUST MOVE FREELY.

Item	Description	Part Number	Qty
1	Motor Pan Assembly TMX428	317-Various	1
2	Side Channel LH Weldment	317-704-001	1
3	Side Channel RH Weldment	317-705-001	1
4	Rear Foot	317-706-001	1
5	Stem Bumper	317-160-141	2
6	Bracket Motor Pan Right	317-708-001	1
7	Bracket Motor Pan Left	317-707-001	1
8	Bolt HHCS 1/4-20 x .75" LG GR 5	001-1186	26
9	Flat Washer 1/4" Dia	001-1439	26
10	Lock Washer 1/4" Dia	001-1450	26
11	Nut HN ¼-20 Grade 5	001-1386	26
12	Landing Gear Assembly	317-702-001	1
13	Bumper 1.8" Dia Black	317-160-106	2
14	Shoulder Bolt HSHSS 5/8" Dia x 1" LG	001-1730	2
15	Elevation Delrin Spacer	317-160-060	4
16	Flat Washer ½" Dia	001-1443	2
17	Nylon Lock Nut NLN 1/2"-13	001-1676	2
18	Bolt HHCS 3/8-16 x 3" Lg Grade 5	001-1699	1
19	Washer Nylon	317-160-086	4
20	Nylon Lock Nut 3/8-16	001-1430	1
21	Belt Drive	317-160-026	1
22	Anti Slip Safety Walk "Cut 1.5" x 4"	317-160-084	2

# Deck Assembly

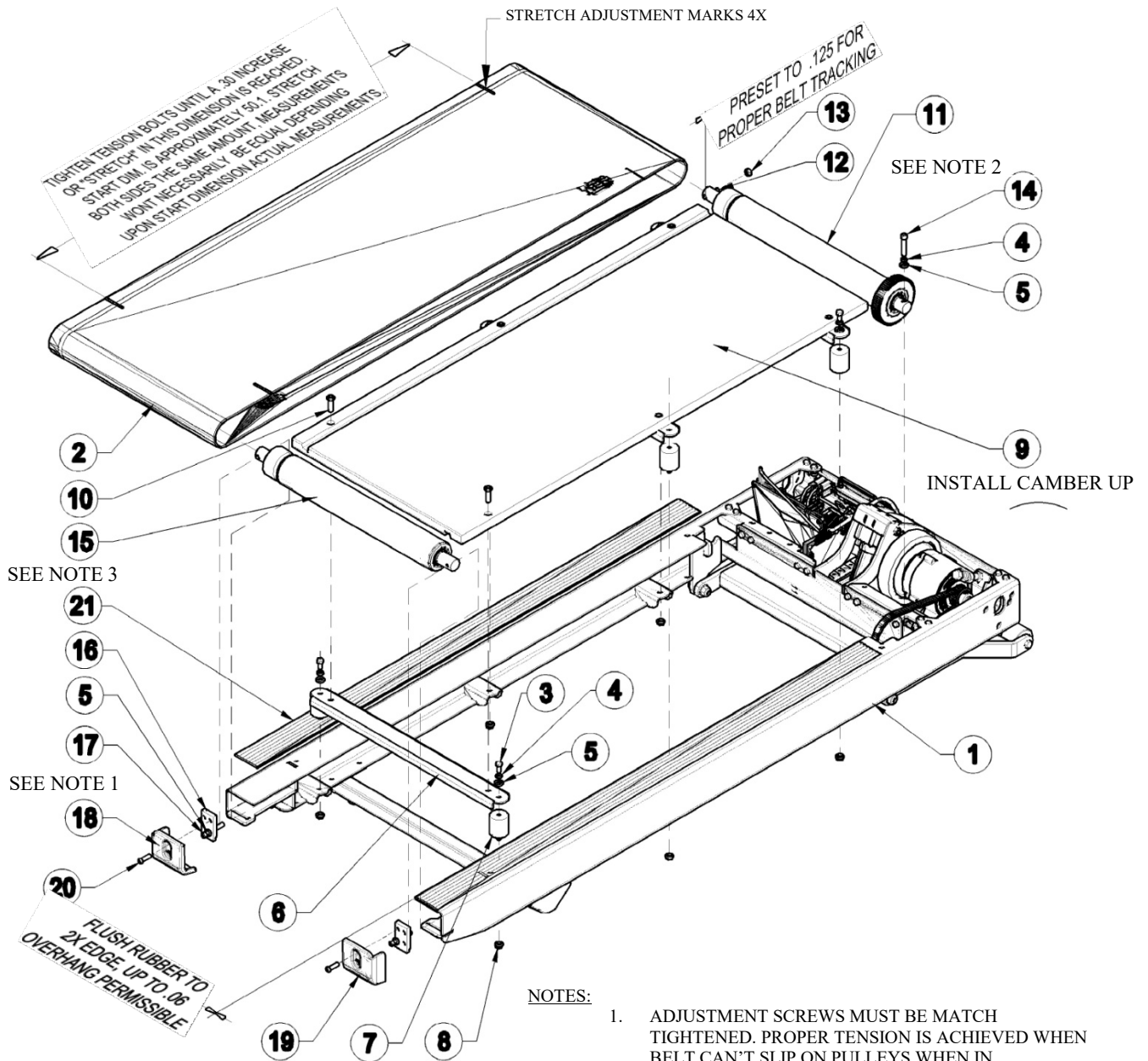

**NOTES:**

1. ADJUSTMENT SCREWS MUST BE MATCH TIGHTENED. PROPER TENSION IS ACHIEVED WHEN BELT CAN'T SLIP ON PULLEYS WHEN IN OPERATION ACHIEVED
2. ADJUST DRIVE BELT TENSION PULLING ALL FREE PLAY OUT OF BELT. DO NOT OVER TIGHTEN CAUSING THE BELT TO STRETCH.
3. MOVE REAR PULLEY SIDE TO SIDE IN CHANNELS TO OBTAIN FRONT TO REAR BELT ALIGNMENT AND TRACKING.

**Deck Assembly continued**

<b>Item</b>	<b>Description</b>	<b>Part Number</b>	<b>Qty</b>
1	Frame Assembly TMX428	317-Various	1
2	Belt Running with V-Guide	317-160-002	1
3	Bolt HHCS 5/16-18 x .75" LG	001-1167	6
4	Lock Washer 5/16" Dia	001-1451	7
5	Flat Washer 5/16" Dia	001-1440	9
6	Deck Support Channel Weldment	317-379-001	3
7	Deck Isolator 1.75" Dia with Stud	317-345-003	6
8	Flange Lock Nut HNS 5/16-18	001-1398	6
9	Deck Running Board	317-160-025	1
10	Screw HSFCHCS 5/16"-18 x 1.5" Lg PLTD	001-1739	6
11	Roller Front	317-160-156	1
12	Set Screw 5/16"-18 x 1.75" LG	317-160-224	1
13	Nut FHNZ 5/16-18 Grade 5	001-1387	1
14	Bolt HSHCS 5/16"-18 x 2" LG PLTD	001-1748	1
15	Rear Roller	317-160-157	1
16	Belt Tension Plate	317-649-001	2
17	Screw HSHCS 5/16"-18 x 3" LG PLTD	001-1737	2
18	End Cap LH	317-160-175	1
19	End Cap RH	317-160-176	1
20	Screw HSBHCS 5/16"-18 x 1" LG PLTD	001-1735	2
21	Extrusion Anti Skid Rubber 60" LG	317-160-401	2

**Final Assembly**  
**NOTE:** The pull tether clip needs to be seated OR magnet needs to be in place for the treadmill to operate as designed.

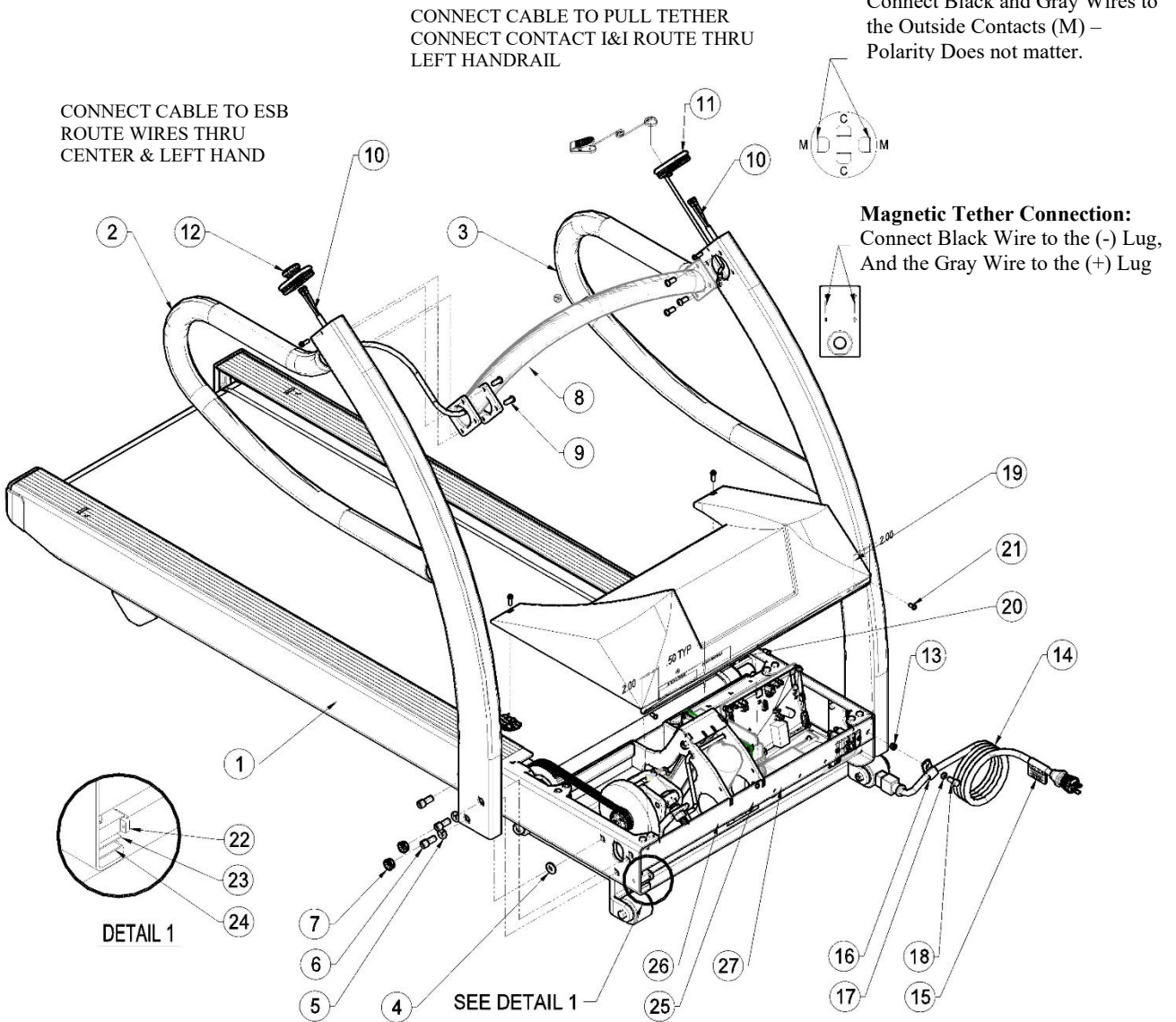

**Final Assembly Continued**

<b>Item</b>	<b>Description</b>	<b>Part Number</b>	<b>Qty</b>
<b>1</b>	Running Deck Assembly TMX428	317-Variou	1
<b>2</b>	Handrail RH TMX428	317-712-001	1
<b>3</b>	Handrail LH TMX428	317-713-001	1
<b>4</b>	Washer Nylon	317-160-086	2
<b>5</b>	Lock Washer 3/8"	001-1452	4
<b>6</b>	Screw HSHCS 3/8"- 16 x 1" LG PLTD	001-1859	6
<b>7</b>	Dome Plug	317-180-008	4
<b>8</b>	Handrail Center TMX428	317-711-001	1
<b>9</b>	Screw HSBHCS 1/4"-20 x 3/4" LG	001-2351	8
<b>10</b>	Harness ESB & Pull Tether	317-160-263	2
<b>11</b>	Pull Tether Assembly	317-720-001	1
<b>12</b>	Emergency Stop Assembly RAFI Emergency Stop Assembly IDEC	317-721-001 317-722-001	1
<b>13</b>	Riv-Nut 1/4"-20	001-1686	1
<b>14</b>	Power Cord 110-120 VAC C-19 NEMA 5- 15 Power Cord 220-240 VAC C-19 NEMA 6- 15 Power Cord 230 VAC C-19 AS/NZS 3112 Power Cord 200-240 VAC C-19 CEE 7/7 EURO Power Cord 250 VAC C-19 Type N Brazil Power Cord 230 VAC C-19 UK BS1363	317-160-219 317-160-242 317-160-319 317-160-189 317-160-362 317-160-188 317-160-318 317-160-361 317-160-339 317-160-363 317-160-364 317-160-362	1

	Power Cord 240 VAC C-19 BS546 3 pin Option Power Cord 250 VAC C-19 Type K Danish Power Cord 240 VAC C-19 GB1002 Power Cord 250 VAC C-19 Type H Israel Power Cord 250 VAC C-19 Type L Italy Power Cord 250 VAC V-19 Type J Swiss		
<b>15</b>	Decal Hi-Pot Power Cord	317-160-258	1
<b>16</b>	Clamp Support	317-160-092	1
<b>17</b>	Lock Washer 1/4"	001-1450	1
<b>18</b>	Bolt HHCS 1/4"-20 x 3/4" Lg Gr 5	001-2351	1
<b>19</b>	Hood TMX428	317-160-235	1
<b>20</b>	Decal Caution	317-160-018	1
<b>21</b>	Screw HHWHTS #8- 32 x 3/8" LG	001-1744	5
<b>22</b>	Test Plug	317-187-003	1
<b>23</b>	Velcro Hook Backing 1" LG	317-160-056	1"
<b>24</b>	Velcro Backing 1" LG	317-160-057	1"
<b>25</b>	Decal Serial	317-Various	1
<b>26</b>	Decal ETL	317-160-271	1
<b>27</b>	Decal Wheelie Bin	317-160-164	1

# TMX428CP Controller Assembly 3rd Edition

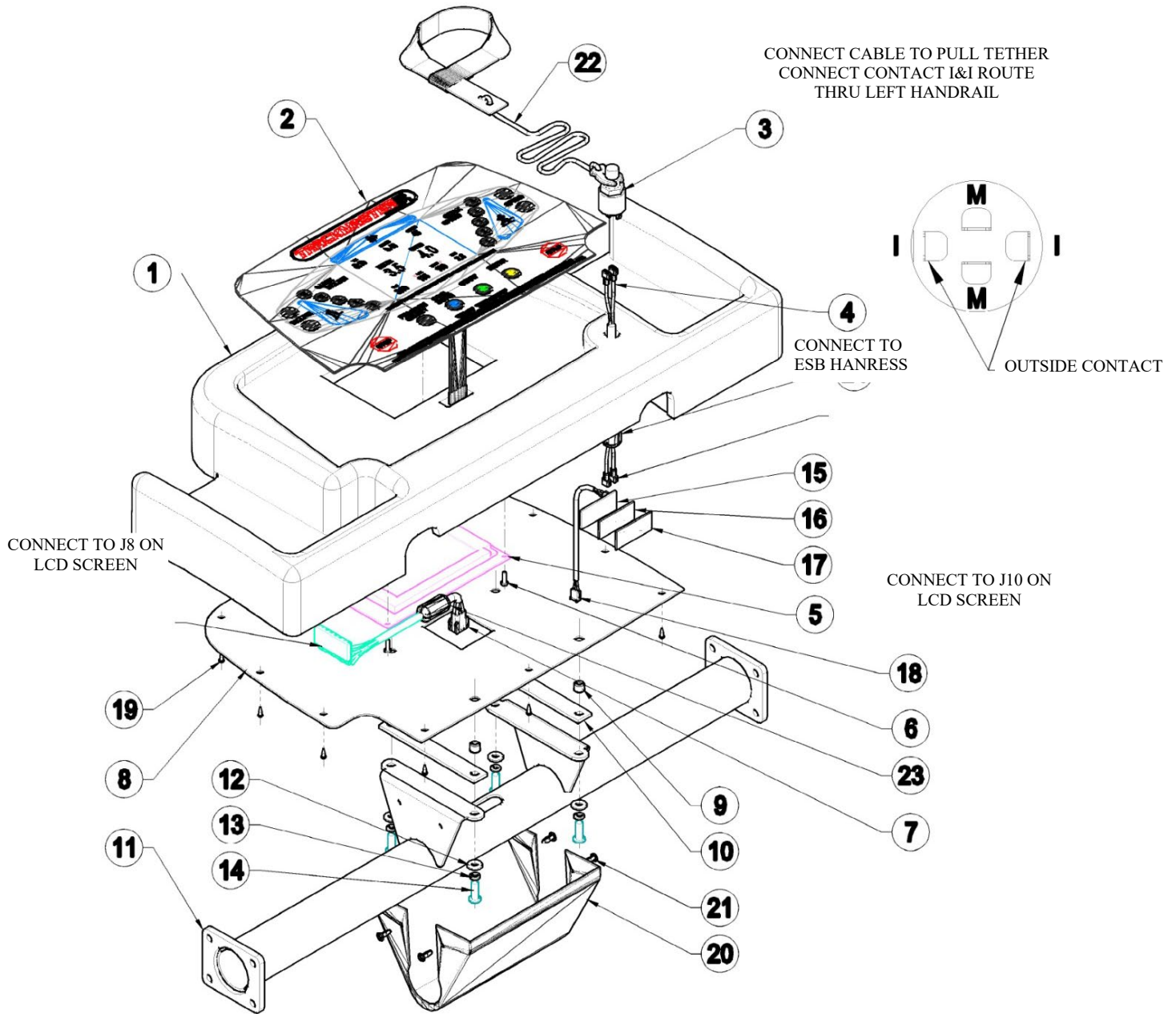

**TMX428CP Controller Assembly 3rd Edition Continued**

<b>Item</b>	<b>Description</b>	<b>Part Number</b>	<b>Qty</b>
1	Console Plastic LCD Configuration	317-160-270	1
2	Membrane TMX428 Overlay	317-160-232	1
3	E-Stop Kill Switch LS500	317-160-226	1
4	Harness Jumper Pull Tether	317-160-266	1
5	Board FG0960-0 Console	417-160-017	1
6	RHMS #6-32 3/8" LG	001-1745	4
7	Harness Communication Jumper	317-160-265	1
8	Back Plate Fitness Panel	317-731-001	1
9	Fastener 1/4-20 UNC Riv-Nut	001-1686	4
10	Rubber Control Dampener	317-160-277	2
11	Handrail Controller TMX428CP	317-719-001	1
12	Flat Washer 1/4" Dia	001-1439	4
13	Lock Washer 1/4" Dia	001-1450	4
14	Screw BHSCS 1/4"-20 x 3/4"	001-2351	4
15	Polar Board FG0315	317-160-168	1
16	Velcro Hook 5/8" x 2" LG	317-160-056	1
17	Velcro Loop 5/8" x 2" LG	317-160-057	1
18	Polar Cable 3-pin 12" CA0045	317-160-169	1
19	K-Lock Nut #6-32	001-1823	10
20	Cover Plastic Controller	317-160-234	1
21	Screw HSBHCS 10-32 x 1/2" LG	001-2334	4
22	Tether Pull W/Wrist Strap	317-160-229	1
23	Fair-Rite Ring 0446164951	317-160-290	1
24	Fair-Rite Ring 0461164281	317-160-291	1

# TMX428CP Controller Assembly 4th Edition

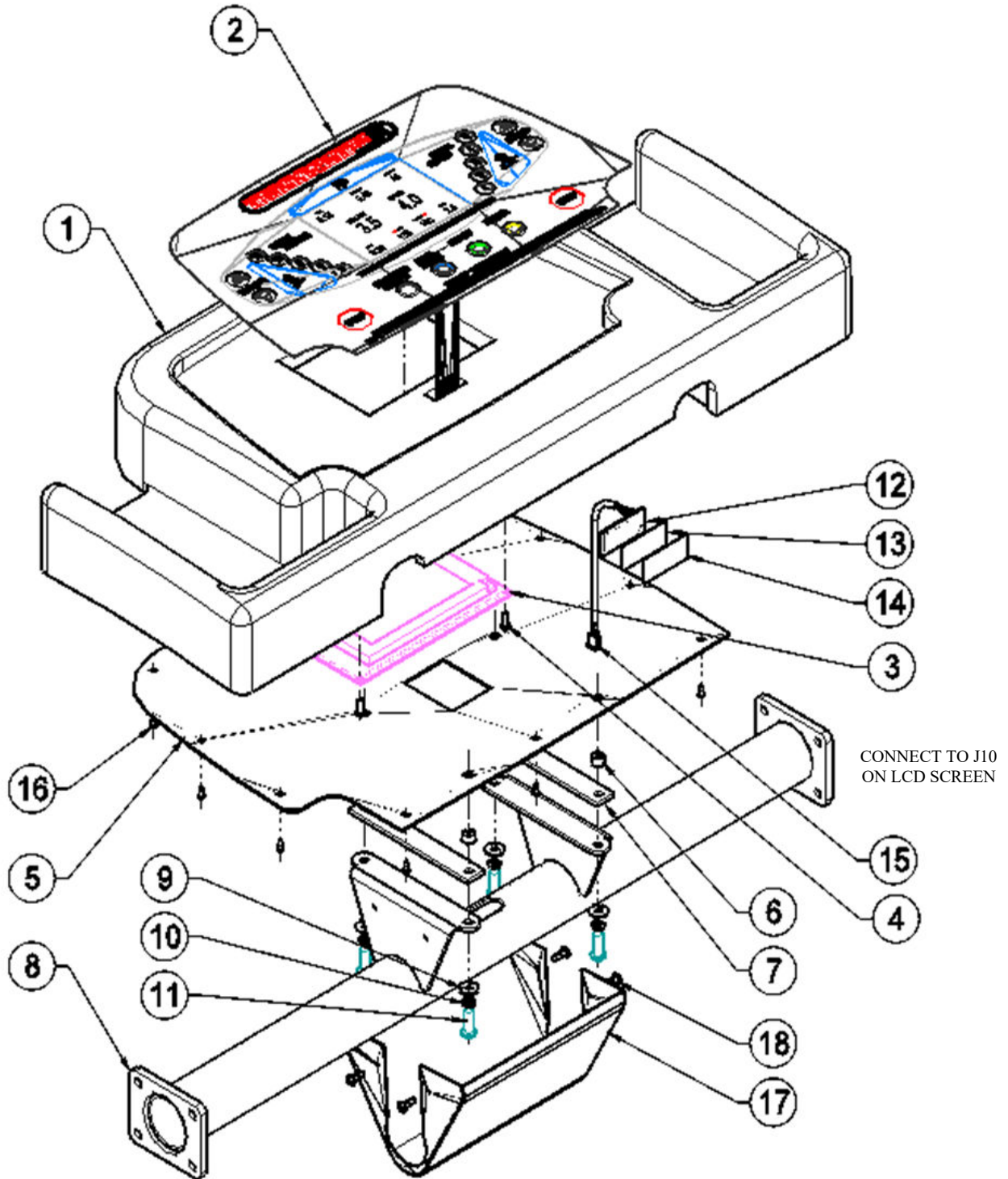

**TMX428CP Controller Assembly 4th Edition Continued**

<b>Item</b>	<b>Description</b>	<b>Part Number</b>	<b>Qty</b>
1	Console Plastic LCD Configuration	317-160-270	1
2	Membrane TMX428 Overlay	317-160-232	1
3	Board FG0960-0 Console	417-160-017	1
4	RHMS #6-32 3/8" LG	001-1745	4
5	Back Plate Fitness Panel	317-731-001	1
6	Fastener 1/4-20 UNC Riv-Nut	001-1686	4
7	Rubber Control Dampener	317-160-277	2
8	Handrail Controller TMX428CP	317-719-001	1
9	Flat Washer 1/4" Dia	001-1439	4
10	Lock Washer 1/4" Dia	001-2351	4
11	Screw BHSCS 1/4"-20 x 3/4"	001-1796	4
12	Polar Board FG0315	317-160-168	1
13	Velcro Hook 5/8" x 2" LG	317-160-056	1
14	Velcro Loop 5/8" x 2" LG	317-160-057	1
15	Polar Cable 3-pin 12" CA0045	317-160-169	1
16	K-Lock Nut #6-32	001-1823	10
17	Cover Plastic Controller	317-160-234	1
18	Screw HSBHCS 10-32 x 1/2" LG	001-2334	4

# TMX58 Controller Assembly 3<sup>rd</sup> Edition Configuration

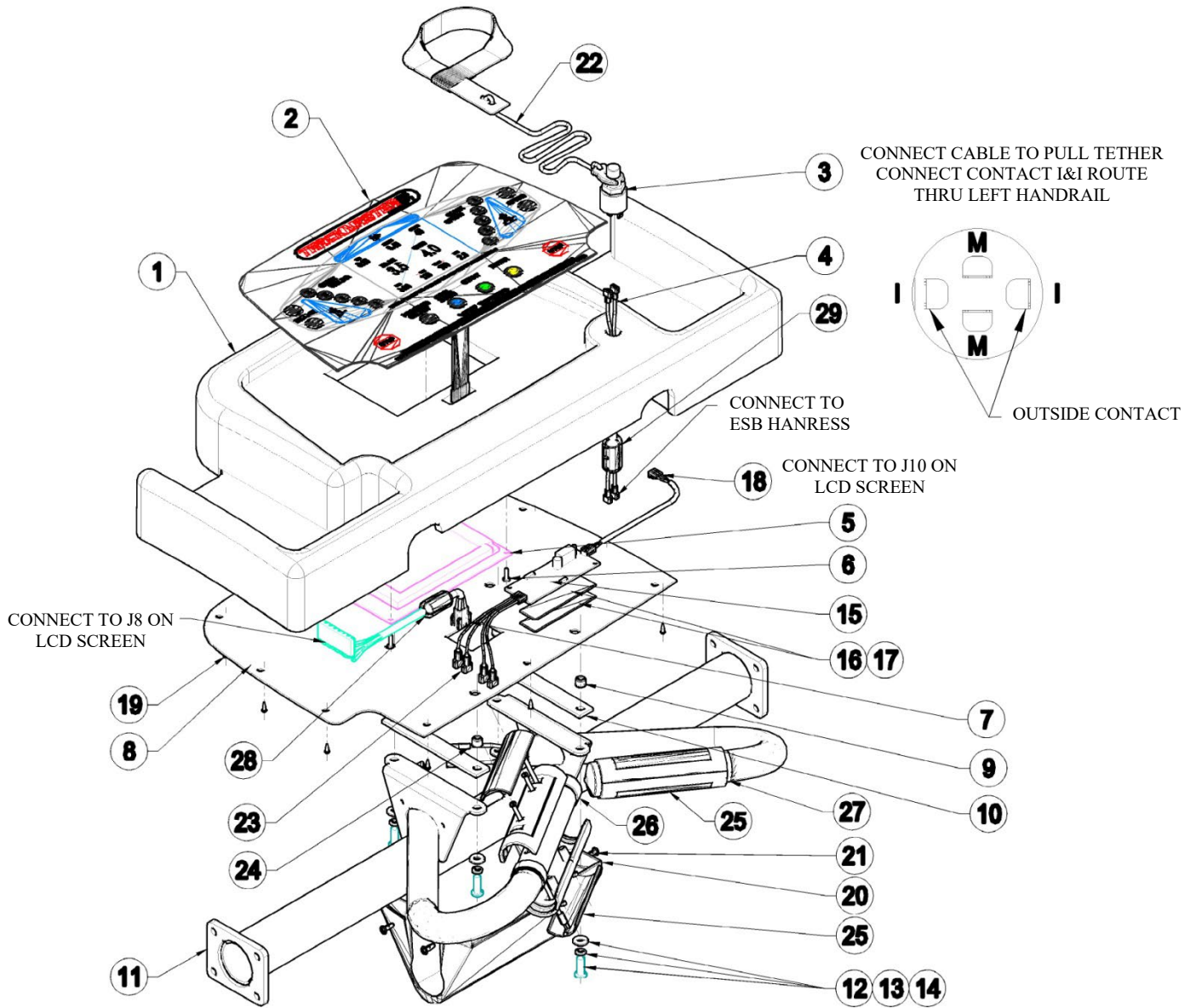

**TMX58 Controller Assembly 3<sup>rd</sup> Edition Configuration Continued**

<b>Item</b>	<b>Description</b>	<b>Part Number</b>	<b>Qty</b>
1	Console Plastic LCD Configuration	317-160-270	1
2	Membrane TMX428 Overlay	317-160-232	1
3	E-Stop Kill Switch LS500	317-160-226	1
4	Harness Jumper Pull Tether	317-160-266	1
5	Board FG0960-0 Console	417-160-017	1
6	RHMS #6-32 3/8" LG	001-1745	4
7	Harness Communication Jumper	317-160-265	1
8	Back Plate Fitness Panel	317-731-001	1
9	Fastener 1/4-20 UNC Riv-Nut	001-1686	4
10	Rubber Control Dampener	317-160-277	2
11	Handrail Controller TMX58	317-714-001	1
12	Flat Washer 1/4" Dia	001-1439	4
13	Lock Washer 1/4" Dia	001-1450	4
14	Screw BHSCS 1/4"-20 x 3/4" SS	001-1796	4
15	Polar Board Royal Medical	317-160-221	1
16	Velcro Hook 5/8" x 3" LG	317-160-056	1
17	Velcro Loop 5/8" x 3" LG	317-160-057	1
18	Polar Cable 3-pin 12" CA0045	317-160-169	1
19	K-Lock Nut #6-32	001-1823	10
20	Cover Plastic Controller	317-160-234	1
21	Screw HSBHCS 10-32 x 1/2" LG	001-2334	4
22	Tether Pull W/Wrist Strap	317-160-229	1
23	Harness Jumper Polar Grip	317-160-267	1
24	Harness Grip ESD	317-390-015	2
25	Grips Polar Kit	317-390-008	1
26	Shim Grip Cap	317-390-013	2
27	Shim Grip	317-390-012	2
28	Fair-Rite Ring 0446164951	317-160-290	1
29	Fair-Rite Ring 0461164281	317-160-291	1

# TMX58 Controller Assembly 4<sup>th</sup> Edition Configuration

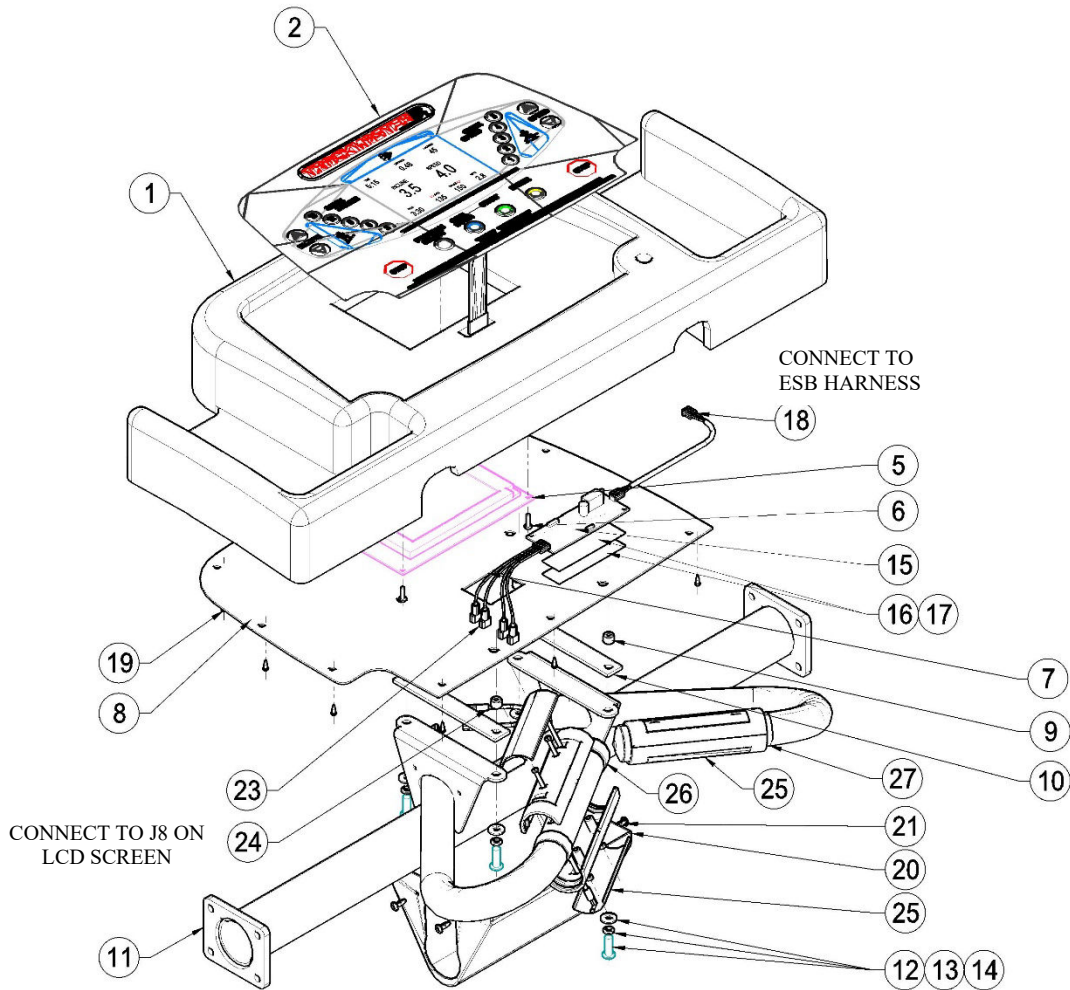

## TMX58 Controller Assembly 4<sup>th</sup> Edition Configuration Continued

Item	Description	Part Number	Qty
1	Console Plastic LCD Configuration	317-160-270	1
2	Membrane TMX428 Overlay	317-160-232	1
3	Not Used		
4	Not Used		
5	Board FG0960-0 Console	417-160-017	1
6	RHMS #6-32 .375 LG	001-1284	4
7	Not Used		
8	Back Plate Fitness Panel	317-731-001	1
9	Fastener 1/4-20 UNC Riv-Nut	001-1686	4
10	Rubber Control Dampener	317-160-277	2
11	Handrail Controller TMX58	317-714-001	1
12	Flat Washer 1/4" Dia	001-1439	4
13	Lock Washer 1/4" Dia	001-1450	4
14	Screw BHSCS 1/4"-20 x .75	001-2351	4
15	Polar Board Royal Medical	317-160-221	1
16	Velcro Hook 5/8" x 3" LG	317-160-056	1
17	Velcro Loop 5/8" x 3" LG	317-160-057	1
18	Polar Cable 3-pin 13" CA0045	317-160-169	1
19	K-Lock Nut #6-32	001-1823	10
20	Cover Plastic Controller	317-160-234	1
21	Screw HSBHCS 10-32 x .50" LG	001-2334	4
22	Not Used		
23	Harness Jumper Polar Grip	317-160-267	1
24	Harness Grip ESD	317-390-015	2
25	Grips Polar Kit	317-390-008	1
26	Shim Grip Cap	317-390-013	2
27	Shim Grip	317-390-012	2

### Part Kit 317-778-001K - Smart Power Supply Board (SPSB) Hardware, 4th Ed.

Item	Description	Part Number	Qty
1	TRIM - Mini Black	001-102-044	1
2	HHWHTS- #8-32 X .375	001-1744	5
3	HN- #8-32 Nylon (ONLY)	001-1763	5
4	CARTON - 8 X 8 X 8	001-7278-095	1
5	LABEL - 5.5 X 8.5" White	001-7278-220	1
6	BAG-9"X12"X 2MILL ZIP LOCK	001-7278-222	1
7	MOUNT - Invertor Isolation	317-160-040	5

### Part Kit 317-779-001K – Elevation Frame Hardware

Item	Description	Part Number	Qty
1	NLN- 3/8-16	001-1430	2
2	FW- 1/2 Dia - Clear Zinc Plt	001-1443	2
3	HHCS- 3/8-16 X 3.25 Gr 5 - Clear Zinc Plt	001-1519	2
4	NLN- 1/2-13	001-1676	2
5	HSHSS- 5/8 Dia X 1 Long	001-1730	2
6	CARTON - 8 X 8 X 8	001-7278-095	1
7	LABEL - 5.5 X 8.5" White	001-7278-220	1
8	BAG-9"X12"X 2MILL ZIP LOCK	001-7278-222	1
9	WHEEL - Landing Gear	317-160-005	2
10	SPANNER - Wheel	317-160-054	2
11	SPACER - Delrin Elevation	317-160-060	4

### Part Kit 317-780-001K – Elevation Actuator Hardware

Item	Description	Part Number	Qty
1	GREASE - Tube	317-160-165	1
2	WASHER - Nylon	317-160-086	8
3	BAG-9"X12"X 2MILL ZIP LOCK	001-7278-222	1
4	LABEL - 5.5 X 8.5" White	001-7278-220	1
5	CARTON - 8 X 8 X 8	001-7278-095	1
6	HHCS- 3/8-16 X 5.00 Gr 5 - Clear Zinc Plt	001-1743	1
7	HHCS- 3/8-16 X 3.00 Gr 5 - Clear Zinc Plt	001-1699	1
8	FW- 3/8 Dia - Clear Zinc Plt	001-1441	3
9	NLN- 3/8-16	001-1430	2

## Part Kit 317-781-001K – Speed Sensor w/ 3-Wire Harness

Item	Description	Part Number	Qty
1	Part Kit – Speed Sensor w/ 3-Wire Harness	37-781-001K	1

### For Reference – Manufacturer’s Description for Individual Items

Item	Description	Part Number	Qty
1	HARNESS - SPEED SENSOR 3 WIRE	317-160-405	1
2	SENSOR SPEED 3 WIRE HALL EFFECT	317-160-404	1
3	TIE - Cable .10 Wide X 4.0 Lg	317-160-075	1
4	LOOP - 5/8" Scotchmate Backing	317-160-057	1
5	HOOK - 5/8" Scotchmate Backing	317-160-056	1
6	BAG-9"X12"X 2MILL ZIP LOCK	001-7278-222	1
7	LABEL - 5.5 X 8.5" White	001-7278-220	1
8	CARTON - 8 X 8 X 8	001-7278-095	1

## Part Kit 317-782-001K – RS232 & USB Comm Port Assy.

Item	Description	Part Number	Qty
1	Part Kit – RS232 & USB Comm Port Assy.	317-782-001K	1

### For Reference – Manufacturer’s Description for Individual Items

Item	Description	Part Number	Qty
1	PLATE RS232 & USB	317-160-254	1
2	CABLE USB A PANEL TO USB B	317-160-237	1
3	CABLE RS232 PANEL MOUNT	317-160-236	1
4	TIE - Cable .10 Wide X 4.0 Lg	317-160-075	1
5	BAG-9"X12"X 2MILL ZIP LOCK	001-7278-222	1
6	LABEL - 5.5 X 8.5" White	001-7278-220	1
7	CARTON - 8 X 8 X 8	001-7278-095	1
8	RHMS #4-40 X .375 LG	001-2360	2
9	HHCS- #8-32 X .50 Gr 2 - Clear Zinc Plt	001-1764	2
10	HNS- #8-32 Flanged Gr 2 - Clear Zinc Plt	001-1636	2

## Part Kit 317-783-001K– Power Inlet & Switch Assy.

Item	Description	Part Number	Qty
1	Part Kit – Power Inlet & Switch Assy.	317-783-001K	1

### For Reference – Manufacturer’s Description for Individual Items

Item	Description	Part Number	Qty
1	RHMS - #6-32 X .500 LG	001-1851	2
2	K-LOCK NUT #6-32 (37405)	001-1858	2
3	CARTON - 8 X 8 X 8	001-7278-095	1
4	LABEL - 5.5 X 8.5" White	001-7278-220	1
5	BAG-9"X12"X 2MILL ZIP LOCK	001-7278-222	1
6	SWITCH TA35-C324L200C0	317-160-256	1
7	POWER CORD INLET C-20 4793.400	317-160-257	1
8	PLATE - SWITCH TMX428	317-718-001	1

## Part Kit 317-784-001K– Power Inlet & Switch Assy. Alternate

Item	Description	Part Number	Qty
1	Part Kit – Power Inlet & Switch Assy. Alternate	317-784-001K	1

### For Reference – Manufacturer’s Description for Individual Items

Item	Description	Part Number	Qty
1	RHMS - #6-32 X .500 LG	001-1851	2
2	K-LOCK NUT #6-32 (37405)	001-1858	2
3	CARTON - 8 X 8 X 8	001-7278-095	1
4	LABEL - 5.5 X 8.5" White	001-7278-220	1
5	BAG-9"X12"X 2MILL ZIP LOCK	001-7278-222	1
6	SWITCH TA35-C324L200C0	317-160-256	1
7	POWER CORD INLET C-20 4793.400	317-160-257	1
8	PLATE - SWITCH TMX428 ALTERNATE	317-776-001	1

## Part Kit 317-785-001K– Part Kit - Running Deck Hardware/Isolators

Item	Description	Part Number	Qty
1	Part Kit – Part Kit - Running Deck Hardware/Isolators	317-785-001K	1

**For Reference – Manufacturer’s Description for Individual Items**

Item	Description	Part Number	Qty
1	HHCS- 5/16-18 X .75 Gr 5 - Clear Zinc Plt	001-1167	6
2	HNS- 5/16-18 Flanged Gr 5 - Clear Zinc Plt	001-1398	6
3	FW- 5/16 Dia - Clear Zinc Plt	001-1440	6
4	LW- 5/16" DIA Split - Clear Zinc Plt	001-1451	6
5	CARTON - 8 X 8 X 8	001-7278-095	1
6	LABEL - 5.5 X 8.5" White	001-7278-220	1
7	BAG-9"X12"X 2MILL ZIP LOCK	001-7278-222	1
8	ISOLATOR - 1.75 Dia W/Stud	317-345-003	6

**Part Kit 317-786-001K– Part Kit - Roller Adjustment Hardware, Front & Rear**

Item	Description	Part Number	Qty
1	Part Kit – Part Kit - Roller Adjustment Hardware, Front & Rear	317-786-001K	1

**For Reference – Manufacturer’s Description for Individual Items**

Item	Description	Part Number	Qty
1	HN- 5/16-18 Gr 5 - Clear Zinc Plt	001-1387	1
2	FW- 5/16 Dia - Clear Zinc Plt	001-1440	11
3	LW- 5/16" DIA Split - Clear Zinc Plt	001-1451	7
4	HSBHCS- 5/16-18 X 1.00 Plated	001-1735	2
5	HSHCS- 5/16-18 X 3.00 Plated*	001-1737	2
6	HSHCS- 5/16-18 X 2.00 Plated	001-1748	1
7	CARTON - 8 X 8 X 8	001-7278-095	1
8	LABEL - 5.5 X 8.5" White	001-7278-220	1
9	BAG-9"X12"X 2MILL ZIP LOCK	001-7278-222	1
10	CAP - LH End FVX	317-160-175	1
11	CAP - RH End FVX	317-160-176	1
12	SET SCREW 5/16-18 X 1.75" LG	317-160-224	1
13	PLATE - BELT TENSION FVX	317-649-001	2

## Part Kit 317-787-001K– Part Kit - Handrail Hardware, Left & Right

Item	Description	Part Number	Qty
1	Part Kit – Part Kit - Handrail Hardware, Left & Right	317-787-001K	1

### For Reference – Manufacturer’s Description for Individual Items

Item	Description	Part Number	Qty
1	LW- 3/8" DIA Split - Clear Zinc Plt	001-1452	4
2	HSHCS- 3/8-16 X 1.00 PLTD	001-1859	6
3	HSBHCS- 10-32 X .50" LG	001-2334	2
4	HSBHCS- 1/4-20 X 3/4" LG	001-2351	8
5	CARTON - 8 X 8 X 8	001-7278-095	1
6	LABEL - 5.5 X 8.5" White	001-7278-220	1
7	BAG-9"X12"X 2MILL ZIP LOCK	001-7278-222	1
8	WASHER - Nylon	317-160-086	2
9	PLUG - Dome .812 Diameter	317-180-008	4

## Part Kit 317-788-001K– Conversion Kit - Quantum w/ Resistor

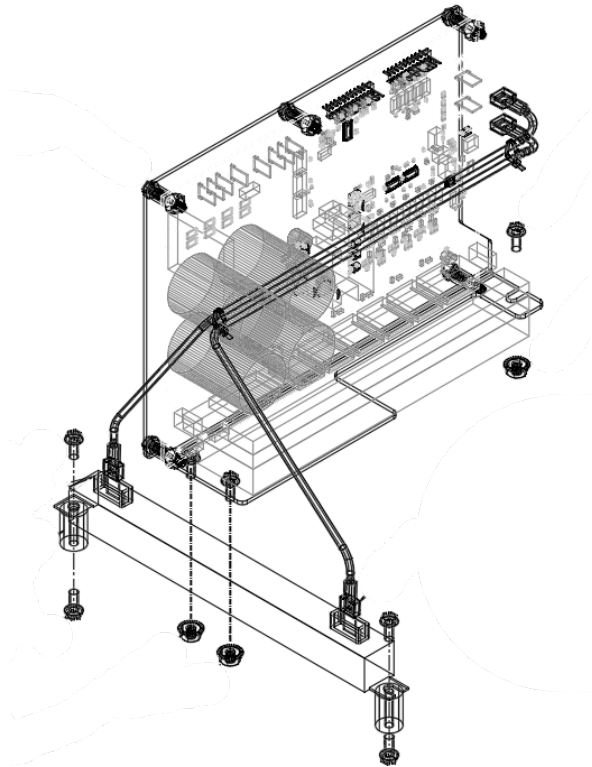

Item	Description	Part Number	Qty
1	Part Kit – Conversion Kit - Quantum w/ Resistor	317-788-001K	1

### For Reference – Manufacturer’s Description for Individual Items

Item	Description	Part Number	Qty
1	HNS- #8-32 Flanged Gr 2 - Clear Zinc Plt	001-1636	4
2	HHWHTS- #8-32 X .375	001-1744	5
3	HHWHTS- #10-32 X .375	001-1755	4
4	HN- #8-32 Nylon (ONLY)	001-1763	5
5	HHCS- #8-32 X .50 Gr 2 - Clear Zinc Plt	001-1764	3
6	MOUNT - Invertor Isolation	317-160-040	5
7	RESISTOR 85/150MJ40R0DE	317-160-233	1
8	NYLON ISOLATOR 10-32x.5 ODx1.0	317-160-259	2
9	DECAL PCB QUANTUM CONTROL	317-160-453	1
10	DRIVE - QUANTUM 800-00112620R0A	317-160-474	1
11	HARNESS - External Resistor	317-160-475	1
12	DRIVE BRACKET QUANTUM	317-762-001	1





# Reprocessing Instructions

The following reprocessing instructions apply to all treadmills. The treadmill is neither sterile nor can it be sterilized.

Manufacturer: Full Vision Inc		Symbol: 
Device(s): Treadmills		
<b>WARNINGS</b>	<p>Before cleaning the device, turn the main power switch to OFF and disconnect the treadmill from its power outlet.</p> <p>Never use wet cleaning materials near a power source: you could suffer an electrical shock.</p> <p>Do not improperly clean the device</p> <ul style="list-style-type: none"> <li>• During cleaning, do not allow fluid to enter the motor pan assembly area.</li> <li>• Always wear appropriate PPE when cleaning.</li> <li>• Do not use abrasive brushes or abrasive cleaners. This could damage the paint and plastic surfaces.</li> <li>• Do not use sharp tools (e.g. knife, metal scraper) or aggressive cleaning solvents for cleaning</li> <li>• Alcohols are flammable and should only be used in well ventilated spaces</li> <li>• DO NOT use disinfection with a phenol base or peroxide compound to disinfect the external surface</li> </ul>	
Limitations on Processing	Not Applicable	

<b>INSTRUCTIONS</b>	
Initial Treatment at the Point of Use	Use a soft, clean, lint-free cloth / paper towel dampened (not wet) with tap water and mild detergent to wipe all treadmill surfaces to remove excess soil, moisture, and perspiration.
Preparation Before Cleaning	All cleaning solutions should be prepared at the dilution and temperature recommended by the manufacturer.
Cleaning: Automated	Not applicable
Cleaning: Manual	<p>Step 1 – Turn the main power switch to OFF and disconnect the treadmill from its power outlet.</p> <p>Step 2 – Use 20 mL (0.68 oz) of an alkaline cleaner or similar mild, non-abrasive detergent (ex. Spray 409) on a soft, clean, lint-free 25 x 25 cm (9.8 x 9.8 in) size cloth / paper towel and manually clean item 1, 2, &amp; 6 (if applicable). Reference Image 1 for</p>

	<p>corresponding items. <b>Note:</b> Do not spray cleaning chemical directly on the device</p> <p>Step 3 – Use an appropriately sized soft-bristled brush (e.g. standard toothbrush) dampened with 5 mL (0.17 oz) of mild soapy tap water (or similar mild, non-abrasive detergent) to clean item 3 and hard to reach spots. Reference Image 1 for corresponding items.</p> <p>Step 4 – Wipe all surfaces 1-6 (reference Image 1) with a soft, clean, lint-free 25 x 25 cm (9.8 x 9.8 in) size cloth / paper towel dampened with 20 mL (0.68 oz) (not wet) of lukewarm tap water 27°C to 44°C (80°F to 111°F) for a minimum of 30 seconds.</p> <p>Step 5 – Dispose of all cleaning materials according to your institutions established procedure.</p>
<p>Disinfection</p>	<p>If necessary, to disinfect the treadmill, follow these steps.</p> <p>Step 1 – Turn the main power switch to OFF and disconnect the treadmill from its power outlet.</p> <p>Step 2 – Prepare 20 mL (0.68 oz) of 70% or greater isopropyl alcohol disinfectant solution according to the manufacturer’s directions.</p> <p>Step 3 – Use a soft, clean, lint-free 25 x 25 cm (9.8 x 9.8 in) size cloth / paper towel or gauze that is saturated with 20 mL (0.68 oz) of the disinfection solution and manually disinfect all contaminated surfaces of the device for a minimum of 15 minutes.</p> <p>Step 4 – Use an appropriately sized soft-bristled brush (e.g. standard toothbrush) dampened with 5 mL (0.17 oz) of the disinfectant solution to clean item 3 and hard to reach spots. (reference Image 1 for corresponding items) Surface must remain wet for a minimum of 15 minutes.</p> <p>Step 5 – Wipe all contaminated surfaces 1-6 (reference Image 1) with a soft, clean, lint-free 25 x 25 cm (9.8 x 9.8 in) size cloth / paper towel or gauze dampened with 20 mL (0.68 oz) of purified water 27°C to 44°C (80°F to 111°F) for a minimum of 30 seconds.</p> <p>Step 6 – Dispose of all cleaning materials according to your institutions established procedure.</p>
<p>Drying</p>	<p>Dry the device with a soft, clean, lint-free cloth/paper towel 25 x 25 cm (9.8 x 9.8 in).</p>
<p>Maintenance, Inspection and Testing</p>	<p>Visually examine each device for cleanliness. If visible soil remains, repeat cleaning procedure until the device is thoroughly clean.</p>
<p>Packaging</p>	<p>Not applicable</p>
<p>Sterilization</p>	<p>Not applicable</p>
<p>Storage</p>	

Additional Information	No additional requirements
Manufacturer Contact	Full Vision Inc. Email: <a href="mailto:tmservice@full-vision.com">tmservice@full-vision.com</a>



Item	Description
1	Emergency Stop Button
2	Patient Grab Handrails
3	Pull Tether Switch / Magnetic Tether
4	Hood
5	Running Belt
6	Controller (if applicable)

The instructions provided have been validated by the manufacturer of the medical device as being capable of preparing a medical device for reuse. It remains the responsibility of the processor to ensure that the processing, as actually performed using equipment, materials and personnel in the processing facility, achieves the desired result. This requires verification and/or validation and routine monitoring of the process.





Assembled in  
Newton, KS. U.S.A.